



# *Construction Manual*

## **ACKNOWLEDGMENTS**

A special thanks to the many friends of Appalachia Service Project who provided suggestions and comments and put into practice the many ideas provided in this manual.

Thank you for making families' homes warmer, safer and drier and transforming lives!

## *NOTE TO THE READER*

This manual is written as a guide in construction methods and techniques used by Appalachia Service Project. Due to differing conditions, tools and individual skills, Appalachia Service Project assumes no responsibility for losses incurred, injuries suffered, or for any damages. Before beginning projects, please review project plans and instructions carefully. If any questions remain, please consult with your ASP staff, Construction Consultant, or the Ministries Department. Projects should always comply with local codes and regulations, and always follow safe work practices.

ASP welcomes comments and feedback about ways to improve this manual. Please contact us by any of these methods:

Write to:      Appalachia Service Project  
                  Construction Manual  
                  4523 Bristol Highway  
                  Johnson City, TN 37601-2937

Email to:      [Construction.Manual@ASPHome.org](mailto:Construction.Manual@ASPHome.org)

© 2015 Appalachia Service Project, Inc. All Rights Reserved.



# TABLE OF CONTENTS

|  |   |            |
|--|---|------------|
|  | <b>SAFETY</b>                                     | <b>5</b>   |
|  | <b>TOOLS &amp; CONSTRUCTION BASICS</b>            | <b>13</b>  |
|  | <b>GIRDERS, PIERS &amp; FOUNDATIONS</b>           | <b>21</b>  |
|  | <b>FLOORS</b>                                     | <b>31</b>  |
|  | <b>WALLS, WINDOWS &amp; DOORS</b>                 | <b>49</b>  |
|  | <b>ROOF FRAMING</b>                               | <b>63</b>  |
|  | <b>ROOF COVERING</b>                              | <b>75</b>  |
|  | <b>ROOF VENTING</b>                               | <b>101</b> |
|  | <b>SIDING</b>                                     | <b>107</b> |
|  | <b>AIR SEALING &amp; INSULATION</b>               | <b>117</b> |
|  | <b>DRYWALL</b>                                    | <b>123</b> |
|  | <b>PRIMING &amp; PAINTING</b>                     | <b>133</b> |
|  | <b>TRIM MOULDING</b>                              | <b>139</b> |
|  | <b>EROSION, DRAINAGE &amp; GUTTERING</b>          | <b>145</b> |
|  | <b>VAPOR BARRIER, UNDERPINNING &amp; SKIRTING</b> | <b>153</b> |
|  | <b>PORCHES</b>                                    | <b>161</b> |
|  | <b>RAMPS</b>                                      | <b>171</b> |
|  | <b>MOBILE HOMES</b>                               | <b>179</b> |
|  | <b>GLOSSARY</b>                                   | <b>185</b> |







# SAFETY

**Construction is inherently dangerous. As such, it is important that you read and understand the following pages.**

Safety of families and work groups is of the utmost importance. In fact, safety is more important than the work you came to accomplish.

Many tasks we must perform during home repair involve dangerous activities which could endanger you or the family you are serving. The risk of serious injury is always present. Please be aware of the conditions, and dangers, that you may face on worksites and always keep safety a priority.

We understand that volunteer groups will have differing levels of experience. If you are not comfortable working on a particular project, please ask the staff to provide your workcrew with an alternative project.

## **SAFETY EQUIPMENT**

Every group must have a first aid kit, a fire extinguisher, a safety manual and a signed Volunteer Statement and Registration Form for every member of your crew in each vehicle.

Most of the equipment needed is easy to carry and comfortable to use. Take the time to find and use these items correctly.

- Gloves to protect hands from blisters, splinters, and cuts
- Goggles to protect eyes from dust, debris, and flying objects
- Dust masks for working on drywall or in dirty situations (minimum N95).
- High quality work shoes
- Long pants, T-shirts and long sleeve shirts for protection from the sun, insulation, paint, and minor scrapes and cuts
- Bug spray to repel mosquitoes, bees, and wasps
- Drinking water to avoid dehydration and cramps
- Hard hats when involved in demolition or when work is going on overhead
- Ear plugs when running noisy equipment, or when working in close proximity to noisy equipment

## **BASIC TOOL SAFETY**

Tools are the most common source of accidents on work sites. Nationally, circular saws and utility knives cause more injury than any other tools used.

## **POWER TOOL SAFETY**

Power tools can shock or electrocute. The tool's action can wind and throw debris, causing severe injury. When using power tools, always follow the checklist below:

- Plug a tool into a grounded outlet unless it is labeled "Double Insulated."
- Use extension cords with the proper amperage for the tool.
- Never remove ground plugs (the third prong) from power cords to get them to work.
- The work area must be cleared of excess people and loose objects, especially under or behind the board being cut.
- Tools should be unplugged when not in use.
- To avoid electrical shock, make sure there is no water near an electrical connection.
- Clothing appropriate to the work being done should be worn.

- Place a sawhorse on firm ground for the safest cutting.
- NEVER use a chain saw at the work site unless trained.
- Do not use power tools overhead.
- Check the power tool before each use for things such as working guards, frayed power cords, sharp blades, etc.
- Wear goggles and ear protection when using, or working around, power tools, especially saws.
- Use heavy-duty drills properly – they can break an arm if not used carefully.

## **HAND TOOL SAFETY**

Hand tools can cause injury if used carelessly. Always make sure to:

- Wear goggles when driving nails to protect eyes from flying nails, pieces of steel from the head of the hammer, or a nail that breaks off from the impact.
- Never strike two hammer heads together; pieces of steel can break off the hammer face, sending metal splinters flying from the impact.
- Keep hands from behind boards being nailed, drilled or cut. This prevents the nail, drill bit, or saw blade from cutting the worker behind the board.
- Cut away from the body when using a knife or chisel.

## **FALLING OBJECTS**

It only takes 600 inch-pounds of kinetic energy to cause a fatal skull fracture. This means that a 10 pound object falling from five feet can kill somebody. A two pound object falling from 25 feet can do the same.

The best way to avoid injury from falling objects is never to walk or crawl under parts of the house being repaired or built. When in these places, make others aware and be alert to these dangers:

- Boards and beams might fall suddenly and without warning. Do not stand or crawl under areas where the house is not fastened or supported securely unless absolutely sure it is safe.
- When removing walls or roofs, make sure the area is clear of people and animals, and that all boards and beams are braced.
- Tools, bottles, and debris on top of ladders or roofs can be dislodged and hit someone below. Carry tools on belts or place them on the ground. Carry construction and demolition debris away from the active work area on an ongoing basis. Do not stand under ladders or the eaves of roofs to avoid falling items.
- When working below overhead construction, everyone must wear an approved hard hat, including those who are removing trash.

## LADDER SAFETY

- Always use the right ladder for the job. An extension ladder is used on a roof. A step ladder is used inside of a house.
- Have someone hold the bottom of an extension ladder when you are ascending or descending from a roof.
- The ladder is to be placed at a 4' to 1' ratio. For every 4' of height, the ladder should be 1' out from the top point of support.
- Check the ladder each time you are using it to make sure that it is safe, and that the rung locks are in position
- A ladder should extend 3' (or 4 rungs) above the roof line.
- Secure the top of the ladder to the roof to keep it from moving horizontally.
- Make sure that the base of the ladder is secure before climbing.
- Instead of reaching out as far as you can, move the ladder. Always maintain your balance.
- Check for overhead hazards, and hazards on the house such as power lines—LOOK UP AND AROUND.
- Don't set up a ladder in front of a door.

## PERSONAL SAFETY

Staying safe around the work site requires alertness and care. Remember, you control the work area. All visitors must follow your work zone safety plan. Be sure to read and follow the below checklist.

- Have a daily safety meeting each morning, a tailgate meeting, (five minutes or less) to talk about the work to be performed that day and the potential risks.
- Have one adult from the work crew on the ground at all times.
- Have an adult watching when a youth uses a power tool, especially a saw.
- Lift carefully. Ask for help in case the object is too heavy or shifts unexpectedly. Lift with your legs, not with your back.
- Stay away from wires. Be aware of wires carrying current into the house, loose wires on the ground, and wires in ceilings or walls.
- Climb carefully. Set ladders one foot from the wall for every four feet they are extended. Have someone steady the ladder on the ground. Do not lean out from the ladder — get down and move it.
- Stay away from power lines.
- Extension ladders should extend 3 foot above the roof line.
- Be observant when walking. Stay out of weeds and away from animals.
- Treat construction and demolition material carefully. Flatten nails if the material is useless.
- Pull nails if the material can be used again. Keep this material away from work areas to avoid tripping or falling.

- Do not crawl under anything until a safety check has been completed. Be aware that bugs, snakes, and small animals take refuge under houses. Supports for houses may be rotted or otherwise unsafe. Proper bracing or additional supports may be necessary. This work must be done with a partner – never alone.
- Stay hydrated. Drink plenty of water, and take regular breaks to prevent exhaustion.
- Climb on roofs only if they are dry and solid. Rubber-soled shoes are essential to avoid slipping. Inspect roof framing and decking from underneath before going on a roof. Keep the number of people on a roof at any one time to a maximum of 4 people. Have one adult from your group on the ground at all times.
- Keep the work site clean (daily). Move all demolition material to the side and away from the volunteers and the family members.
- Keep all new materials in orderly piles, and protected from the weather if necessary.

## **ELECTRICAL HAZARDS**

Potential dangers related to electrical problems should be discussed with a staff member. Exercise caution when working around old, faulty, or exposed wiring and electrical equipment.

Before beginning work, check with the staff to see what permits are required, and that they cover all work. Nobody should work on wiring without the appropriate skills. Licensing may be required.

Please be aware of the following:

- Some states have licensing, code, and inspection requirements. Check with staff about wiring requirements.
- If you are inexperienced, ask for help from a qualified staff member.
- Old wiring may be hidden behind a floor, ceiling, or wall to be removed.
- Fuse boxes, receptacles, or range receptacles without covers.
- Frayed wiring with exposed wire or damaged insulation.
- Blown fuses or breakers may indicate that circuits are overloaded or that a short exists.
- Burn marks on walls or on an outlet indicate a possible short.
- Excessive or improper use of extension cords.
- Wire size must be adequate to handle the tool plugged into it.
- If main switch is hot or has frayed wire, tell staff immediately.
- If wires are discolored (for example, a portion of a red wire is more brown than red) contact the staff. It indicates overheating.
- Report anything that gives an electrical shock.
- Never work with hot or powered electrical circuits. Cut the power at the breaker.
- Replace any fuse holder having pennies as conductors. Check the electrical system for obvious problems before starting work.
- Replace fuses with the same size fuse.

## DEMOLITION PROCEDURES

Removing parts of an existing house to repair and construct an addition can be the most dangerous part of home repair. Carelessly removing a wall without bracing the roof can be disastrous. Standing on loose boards to climb or to work can cause a fall or injury. Be careful, move slowly and deliberately, and follow these instructions:

- Pick up the work area on an ongoing basis, and thoroughly when the work ends for the day.
- Wear gloves, safety glasses, hard hat, dust mask, and long sleeves.
- Always check with the center staff to confirm the need for demolition and to discuss how to minimize disruption of the family living in the house.
- If there is any chance of lead-based paint (LBP) being present, follow precautions on the next page.
- Keep the area clear of debris, particularly sharp boards and nails. To avoid someone stepping on a nail, flatten nails in boards that cannot be reused. Pull and discard nails promptly from boards that can be salvaged. Reuse the good boards.
- Always make sure that your footing is secure. Pry boards carefully, so that if they come loose unexpectedly, a fall or other injury does not occur.
- Do not throw debris, especially from the roof. Check for children, animals as well as fellow volunteers or other people. When dismantling a roof, call down ahead of time, have a helper on the ground to keep the area clear, and hand down all debris if possible.
- Keep upper parts of the house braced when dismantling a wall.
- Watch for wasps nests when removing materials.

## VEHICLES AND DRIVING

Having an improperly loaded vehicle will significantly affect its ability to turn and react to situations on the road.

When loading vehicles, always place the load as far forward in the vehicle as possible. Make sure that the vehicle does not have too much weight on it.

Never load sheet goods over passengers. This is an extremely hazardous. If materials will not fit in the vehicle properly, have the staff deliver the materials.

When driving, be aware of sharp turns. Coal dust left on the roads from trucks can cause roads to be dangerously slick, especially when it first starts to rain.

## **HANDLING ASBESTOS**

The only way to determine the presence of asbestos is to have an accredited laboratory test samples taken by a trained professional. ASP does not work on houses known to have (or suspected of having) asbestos.

If asbestos is suspected during the course of rehabilitation, stop work and contact the staff. This includes friable materials (those that are easy to crumble) such as zonolite, pipe wrap, insulation and fireproofing used behind and under wood stoves, and non-friable materials such as siding tiles, floor tiles and tiles for flat roofs. When in doubt, assume that it is asbestos.

**IF FRIABLE MATERIALS ARE DISCOVERED DURING THE COURSE OF DEMOLITION, SEAL THE EXPOSED AREA AS BEST AS POSSIBLE AND CONTACT STAFF.**

## **HANDLING LEAD PAINT**

Lead Based Paint (LBP) is usually found in pre-1978 homes. Only trained, certified professionals can test for Lead Based Paint. ASP has neither the time nor the resources to test all materials. If there is a material that is suspected of having Lead Based Paint, or has not been tested, always assume that it has lead in it.

ASP does not work on houses suspected of having Lead Based Paint, unless the group leader has been trained in testing, removal and clearance sampling.

Adults generally are exposed through breathing the dust, and children are exposed through ingestion by hand-to-mouth contact.

## **MOLD**

As with other environmental hazards, ASP staff and volunteers do not have the skill or the resources to test for mold, or determine the presence of and/or species of mold.

More than 1000 types of mold with varying degrees of toxicity have been found in US homes. Not all people react to mold in the same way. If mold is suspected and a volunteer has shown signs of a reaction, have that volunteer leave that area of the work zone.

Mold likes places that are dark, and moisture is a requirement for mold growth. "The only way to control indoor mold growth is to control moisture" (EPA). "The only factor that can be controlled is moisture" (NAHB).

ASP will resolve the moisture problem as the first step. When the source of the moisture is identified and fixed, we will attempt limited containment and clean-up using products that are readily available at the local hardware store. These products may include, but not be limited to, Clorox, Tilex, Fantastic, etc. **WE ARE NOT PROFESSIONALS, AND MOLD REMEDIATION IS NOT WHAT WE ARE TRAINED FOR.**

## **NATURAL HAZARDS**

### *HORNETS, WASPS, YELLOW JACKETS AND BEES*

Hornets often build nests under eaves, inside siding and in out-buildings. Before beginning work on an area, examine it thoroughly for nests and activity. When you find them, use a commercial wasp spray that can be applied at a safe distance.

- Look under eaves and under porches for hornet nests.
- Bumblebees and wasps often nest under siding. Before repairing or removing siding, tap along the siding and watch for insect activity.
- Before disturbing insulation, poke around it and watch for insect activity.
- Before working around a house, and in the bushes, examine the area carefully for any insect activity.
- Yellow jackets like to build their nests in the ground. Watch for insects going to and from a particular area.

### *SNAKES AND SPIDERS*

Snakes and spiders are frequent residents around, under and even inside the house. They may be in rock piles, outbuildings, under the house or porch, in insulation, in debris, and in secluded areas. When working in areas where they may be encountered:

- Wear gloves
- Roll or move debris before picking it straight up. Kick things around to give whatever is there a chance to leave. Slide the boards first, and then pick them up.
- Watch when stepping, or jumping, over piles of debris.

### *TICKS AND CHIGGERS*

These insects are typically encountered in brushy, grassy and wooded areas.

- Check yourself periodically, and every evening.
- Chiggers can burrow into the skin, often in soft tissue, and cause a red, itchy bump.
- Wear insect repellent and tuck your pant legs into your socks when working in a weedy area.

### *POISON OAK/IVY*

These are fairly common, and can cause a nasty rash.

- Know what they look like
- Ask the home owner if they are present
- If you come in contact with it, wash with soap and water immediately
- Even if it gets on your clothes, the oil can transfer to your skin
- Let the staff know if it is present

### *DOGS AND CATS*

Always use caution when approaching animals. They are frequently unvaccinated, and carry fleas and ticks.



# TOOLS & CONSTRUCTION BASICS

Tools are vital to any construction project. Without the right tool it can be more difficult to get a job completed or to do the job properly. This section reviews some of the basic tools used in construction projects and highlights their purpose and use. A basic tool set that a volunteer may carry includes a hammer, tape measure, utility knife, ear plugs, goggles, gloves, a pencil and a speed square.

If you are unfamiliar with a term being used, please check the glossary at the end of the manual.

## SPAN CHARTS

| FLOOR JOIST SPAN DATA |                              |                                   |  |
|-----------------------|------------------------------|-----------------------------------|--|
| NOMINAL JOIST SIZE    | SPACING IN INCHES ON CENTER* | MAXIMUM ALLOWABLE SPAN            |  |
|                       |                              | MEDIUM GRADE SOUTHERN YELLOW PINE | SOUTHERN YELLOW PINE WITH DRYWALL ATTACHED |
| 2X6                   | 16"                          | 9'4"                              | 8'0"                                       |
| 2X6                   | 24"                          | 8'1"                              | 6'6"                                       |
| 2X8                   | 16"                          | 12'3"                             | 10'6"                                      |
| 2X8                   | 24"                          | 10'3"                             | 8'9"                                       |
| 2X10                  | 16"                          | 15'5"                             | 13'8"                                      |
| 2X10                  | 24"                          | 12'7"                             | 11'4"                                      |
| 2X12                  | 16"                          | 17'10"                            | 16'2"                                      |
| 2X12                  | 24"                          | 14'7"                             | 12'4"                                      |

| RAFTER SPAN DATA       |                             |                                   |
|------------------------|-----------------------------|-----------------------------------|
| NOMINAL SIZE IN INCHES | SPACING IN INCHES ON CENTER | MAXIMUM SPAN<br>SPRUCE: PINE: FIR |
| 2X6                    | 16"                         | 13'5"                             |
| 2X6                    | 24"                         | 11'9"                             |
| 2X8                    | 16"                         | 17'9"                             |
| 2X8                    | 24"                         | 14'10"                            |
| 2X10                   | 16"                         | 22'3"                             |
| 2X10                   | 24"                         | 18'2"                             |

| MAXIMUM SPAN FOR DOUBLE HEADERS |                      |                 |                   |
|---------------------------------|----------------------|-----------------|-------------------|
| DIMENSION OF LUMBER             | SUPPORTING ROOF ONLY | ONE STORY ABOVE | TWO STORIES ABOVE |
| 2X6                             | 4'                   | 2'              | N/A               |
| 2X8                             | 8'                   | 6'              | 4'                |
| 2X10                            | 10'                  | 8'              | 6'                |

| CEILING JOIST SPAN CHART |                              |   |                  |
|--------------------------|------------------------------|---|------------------|
| NOMINAL JOIST SIZE       | SPACING IN INCHES ON CENTER* | NORTHERN SPRUCE OR SOUTHERN YELLOW PINE |                  |
|                          |                              | LIMITED ATTIC STORAGE                   | NO ATTIC STORAGE |
| 2X4                      | 16"                          | 8'7"                                    | 11'0"            |
| 2X4                      | 24"                          | 7'3"                                    | 9'5"             |
| 2X6                      | 16"                          | 12'10"                                  | 15'10"           |
| 2X6                      | 24"                          | 11'0"                                   | 14'9"            |
| 2X8                      | 16"                          | 16'3"                                   | 19'7"            |
| 2X8                      | 24"                          | 14'0"                                   | 18'9"            |
| 2X10                     | 16"                          | 19'10"                                  | 24'0"            |
| 2X10                     | 24"                          | 16'4"                                   | 22'11"           |

## HAMMERS

### HAMMER BASICS

Curved claw hammers are used for nailing and pulling nails smaller than 16d (“16 penny”). Pulling larger nails may result in breaking the handle of the hammer. Pull larger nails with a crow bar, wonder bar, or wrecking bar. Claw hammers range in weight from 7 to 28 ounces; normal is 16 ounces. Usually a heavier hammer provides ease when driving a nail.

The straight claw or framing hammer is similar to the curved claw hammer but is used for rough work such as framing and dismantling. The straight claw is easier to insert between two boards in order to pry them apart. Its weight ranges from 16 to 28 ounces. Base the selection of a hammer on the user’s size and strength.

Mallets are used when a softer blow is called for, or you are protecting the integrity of the wood. Rubber mallets can be used for shifting plasterboard into place. Wooden mallets are usually used in carpentry to knock wooden pieces together, or to drive dowels or chisels. A wooden mallet will not deform the striking end of a metal tool, as most metal hammers would, and it also reduces the force required to drive the cutting edge of a chisel.

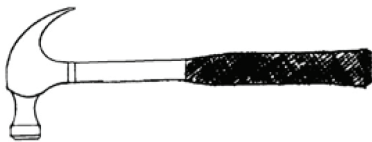

curved claw hammer



straight claw hammer

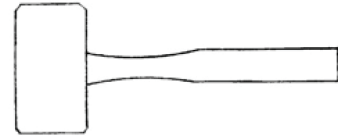

mallet

**Hold the hammer near the end of the handle for maximum leverage and nail driving force.**

When pulling nails with a claw hammer, a block can be placed under the hammer head to increase leverage and minimize marring of the wood, especially on finished surfaces such as window and door trim.

The slightly curved (convex) head of the hammer will minimize marring wood when a nail is driven flush. However, an abused hammer with too much rounding to the head makes it easy for the head to deflect off a nail when struck.

Never use claw hammers on any surface harder than the head itself—such as steel or concrete. Never strike two hammers against each other.

## NAILS

### NAIL BASICS

Nails are available as either galvanized, common or sinkers. Sinkers are the strongest of the three, and less expensive. Galvanized nails are designed specifically for use with pressure treated building materials and outside use.

Nail weight is described in pennies (notated as d). A 2d nail is one inch long. For every  $\frac{1}{4}$ ”, one penny weight is added, up to 16d.

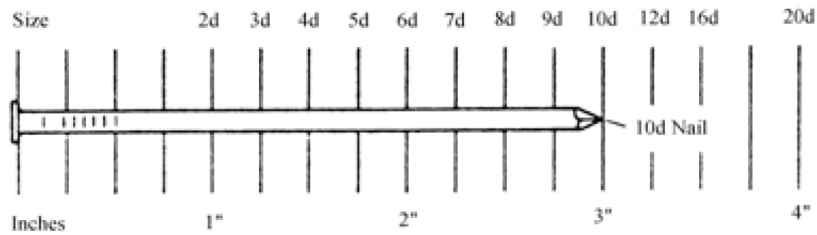

**common:** used for finished lumber and general uses; can be sinker or box



**spiral:** commonly used in siding and flooring, as it tends to not work itself loose



**casing:** similar to a finish nail, but stronger. Used when strength and concealment are necessary



**finish:** used when concealment is necessary; set with a nail set and covered with putty

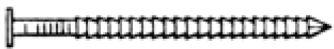

**ring shank:** used when an extremely solid hold is needed- extremely difficult to work loose



**duplex head:** can be driven tight against the first head, and easily removed later

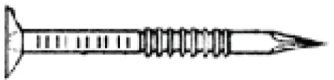

**drywall nail:** used in pairs to hold drywall to the studs



**roofing nail:** used for attaching shingles, as well as in many sheet metal applications

## HOW TO NAIL

To start a nail, hold it between the thumb and index finger. Tap the nail lightly until it will stand on its own. Remove fingers and tap harder until the nail is at least one inch into the wood. Heavy blows before the nail is secure may dislodge the nail and cause injury. Always use safety glasses when nailing.

For nailing roofing nails, hold the nail between the index finger and second finger with the palm up. Tack the nail into place and remove your fingers.

## NAILING WOOD TO WOOD

- Nail through the board being attached into the more sturdy board.
- **Rule of thumb: When nailing two different thicknesses of wood together, nail through the smaller piece first and use a nail two times longer than the thickness of the smaller piece.**
- When joining two pieces of wood, avoid nails which will go all the way through the far side of the second piece of wood. The suction created by the sealed hole creates a stronger hold.
- *Example: When nailing together two 2x4s, use a nail that will not penetrate through the far side of the second piece—in this case, use a 12d nail.*

## TOE NAILING

Toe nailing is a method of driving nails at an angle to attach boards together.

To begin the toe nail, hold the nail perpendicular to the wood and tap it lightly with the hammer to break the surface. Remove the nail, reposition it in the same hole at the desired angle, and drive it in.

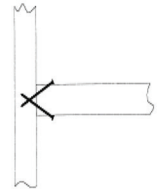

When driving the first nail, the stud will tend to move before the nail enters the second piece of wood. One way to counter this is to place your foot, a set nail, or a block against the opposite side of the board to hold the board. You can also drive the first nail in half way and then drive the second nail all the way in. Then return to the first nail and finish driving it in.

## USING FINISH NAILS

To hide finish nails:

- Drive the nail until the head is within 1/8" of the surface.
- Place the nail set on the nail head and drive the nail into the wood a depth equal to the diameter of the nail head.
- Fill the hole with wood putty.

Nail sets drive a finishing or casing nail below the surface without damaging the wood, and allow you to cover nail heads with wood putty to make them disappear. Nail sets come with various size tips that range in diameter from 1/32" to 5/32".

## SCREWS

In most cases, screws can be substituted for nails.

Screws used on pressure treated wood must be approved for that application.

## LADDERS

A ladder is set up at a 1 to 4 ratio. For every 4 feet of height, the base is 1 foot out from the wall. For example, if the contact point of the ladder is 10 feet off the ground, the base would be 2.5 feet out from the wall. If the contact point is an eave that is 10 feet off the ground and 1 foot out from the wall, the distance at the base would be 3.5 feet.

Use an extension ladder with care. Before climbing, make sure the ladder is firmly footed. Stand on the bottom rung to press feet well into ground. On a smooth surface, use safety treads.

Do not climb higher than the second rung from the top of the ladder and always secure the top of the ladder to prevent side-to-side movement.

When climbing on a roof, make sure that the ladder extends 4 feet above the roof.

If the ground is muddy, it is best to rest the ladder feet on a wide plank. Always climb facing the ladder and never go higher than the second rung from the top. When climbing, bring hands around side of ladder and slide; this prevents letting go. Do not lean out; reach a comfortable distance to the right or left, keeping both feet solidly on the ladder.

A ladder with three or four steps is a good choice for painting walls or ceilings. When painting high ceilings, a stepladder with a folding platform is essential. Be sure that the ladder is sturdy. Do not use a makeshift arrangement. Invest in a new ladder if necessary; it will amply repay the cost in safety and in efficiency.

Also, remember that a step ladder is firmly footed only when the spreader is fully opened and locked. Do not try to climb a stepladder that is in any other position; it is likely to slip or topple.

When painting near a door, either fully open it or close and lock it. Otherwise, if someone opens the door, a fall may occur. Make wall and ceiling painting considerably easier by rigging a raised platform from which to work. Such an arrangement will eliminate the necessity to get up and down constantly to move the stepladder.

When available, scaffolding offers an excellent base from which to work. Assemble scaffolding properly using adequate cross bracing and supporting the legs to prevent them from sinking into the ground. Use ladder jacks on two extension ladders with a scaffold plank to work at higher levels. Scaffold planks (2x8 and up to 18 feet long) sold at lumberyards, are often available on a rental basis from paint stores. A 10 foot length is generally the most useful.

Never leave tools hooked to ladders or left on top of step ladders when not in use. Injury to the next person using the ladder can be the result.

## **POWER TOOLS**

### *POWER TOOL SAFETY*

- BEFORE STARTING ANY POWER TOOL, be certain the electrical system and extension cords can carry the additional amperage.
- Use safety glasses at all times when operating power tools to avoid sawdust, debris, and splinters.
- Always use ear protection.
- Never operate power tools with damaged cords.
- Always unplug tools when not in use or when making adjustments.
- Youth must be supervised by an adult when operating power tools.
- Only use grounded extension cords.
- Never operate corded power tools in the rain or while standing in pooling water.
- Always make sure the cord is safely out of the way prior to starting work.
- Do not use corded power tools on rooftops—use battery-powered tools instead.

### *CIRCULAR SAWS*

Always make sure the cord for any power tool is out of the way before operation is begun.

Always use an appropriate blade for the material being cut. The fewer the number of teeth on a saw blade, the rougher—but faster—the blade will cut. Use sharp multi-tooth blades for doing trim work.

Any finished material (such as paneling or siding) should be cut from the unfinished or backside to prevent the saw blade from splitting the finished surface.

Items like doors that are finished on both surfaces should have the top surface scored at least 1/16" deep with a knife and straight edge. This will prevent tear out. Place masking tape over cut to help eliminate splinters

Cutting wet wood will cause a build-up of sawdust in the blade guard. This will cause the guard to stick and not return to protect the blade. If a build-up of sawdust occurs, unplug the saw and

clean it out. Make sure the blade guard has returned to its proper position before operation is resumed. Never use power equipment that does not have all of its safety devices intact.

### ADJUSTING AND SETTING THE SAW

Although circular saws operate at maximum efficiency when they are adjusted to cut just through the bottom of the work, many users leave the blade at the full-depth adjustment for general work. The difference in performance is only noticeable when cutting thick stock. For safety, it is a good idea to set the saw to 1/4" thicker than the stock being cut. **REMEMBER: Unplug the saw before making adjustments.**

If the tilt angle of the saw was changed for a previous stage of the job, be sure that it is correctly readjusted. Check for right-angle cuts by cutting a scrap piece and using a speed square on the cut section. If the saw needs adjusting for a miter or bevel cut, test the angle by cutting a scrap piece before cutting the pieces to be actually used. A test is also advisable for shallow-depth adjustments and rip fence settings.

When trying out a new saw, become familiar with all the adjustments by making several cuts on scrap wood. In this way, accuracy of the settings on the saw are evident. Use the calibration on the saw, which show angles and distance, as a guide, never for actual measurements. Remember, too, that the width of the saw kerf (cut) and the types of blades used in construction work affect the precision of the final result.

Use turpentine to remove gum, dirt, and pitch from the bottom of the saw. An occasional waxing of the bottom is a good idea. It will help the saw glide smoothly along the work. In addition, make certain that the trigger switch is operating smoothly and that it does not lock inadvertently in the "on" position.

Properly support work to minimize the chance of the saw binding or "kicking" during cutting. Place supports so the cut will be on the outside edge rather than down the middle of the supports.

Keep a sharp blade in the saw. The duller the blade, the more dangerous the saw becomes. Dull

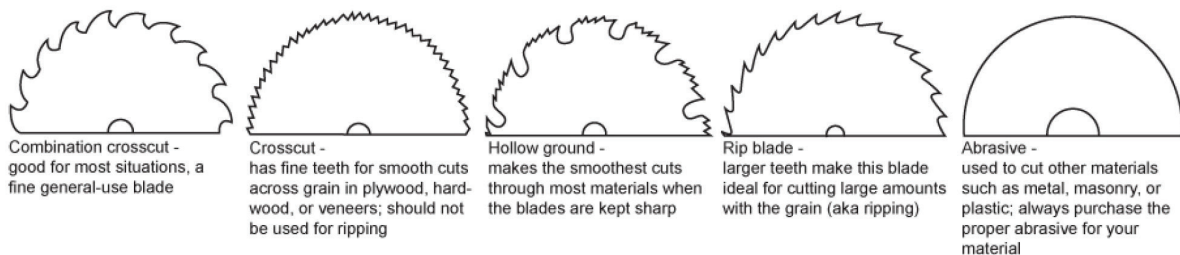

blades lead to "forcing" the saw to work, and can increase incidences of kick-back.

## RECIPROCATING SAWS

Reciprocating saws, also known as saber saws and Sawzalls™, are power saws that use an oscillating blade to cut through wood and metal. It is ideal for rough work and demolition due to its ability to cut vertically and at extreme angles.

When using a reciprocating saw, always rest the shoe (blade guard) against the piece of material that you are cutting before you turn it on. This will prevent the saw and material from vibrating, and minimize kick-back.

When making cuts, always be aware of what is behind what is being cut. Reciprocating saws will cut through plumbing and electrical chords very easily.

There are three types of blades available for reciprocating saws, available in a variety of sizes. *Always make sure that the right blade is being used.*

- Wood cutting blades – designed specifically for the use of wood cutting
- Demolition blades – also known as bi-metal blades, are designed to cut through wood with nails
- Metal blades – designed to cut primarily metal, such as rebar or metal piping

All blades are marked with their teeth per inch (TPI). The fewer teeth the blade has, the rougher the cut will be.

## DRILLS

There are three types of drills typically used on projects:

- Hammer drills – used with concrete. The head of the drill rapidly hammers at the material, breaking it apart, to provide quicker drilling.
- Corded drill – standard drill that uses a cord for power. They are typically more powerful than cordless drills.
- Cordless drills – typically not as powerful as corded drills. They usually have a battery life of three to four hours.

## DRILL BITS

There are several different types of drill bits available. Bits commonly come in two different shaft sizes:  $\frac{3}{8}$ " and  $\frac{1}{2}$ ". Bits fit according to the size of the chuck.

The different types of bits available include:

- Auger bit – used for wood boring. The auger pulls wood chips out of the holes.
- Paddle bit – also known as a spade bit, it is used for wood boring as well, used to create large holes, up to 1  $\frac{1}{2}$ ".
- Hole saw – used for cutting holes 1  $\frac{1}{2}$ " to 6" in wood.
- Metal twist bit – used for light metals only.
- Masonry bit – used to drill in masonry.
- Non-percussion masonry bit - used to drill in masonry with standard drill.



# GIRDERS, PIERS & FOUNDATIONS

## SAFETY

Things to look out for under a house

- Strange chemicals
- Broken glass
- Blackwater
- Animal waste
- Snakes
- Bugs & spiders

Ways to protect yourself while under a house:

- Ample lighting and black plastic. This will provide a more comfortable, well lit environment. Discomfort, low visibility and distractions can contribute to accidents.
- If the area is rocky, request thin blue foam pieces on which to crawl.
- If there is glass on the ground, it will need to be cleaned up, and you will need foam on which to crawl.
- Disposable coveralls (look like hazmat suits) are available for any group that wants them.
- There is no way to make safe an area that has been contaminated with black water. Putting straw, lime or any other chemical or barrier down is not sufficient for remediating black water contamination.
- Before jacking any part of a house, make sure you have braces anywhere you might need them. Keep people away from glass or loose materials high on the walls or ceilings. Shifting a settled house can cause plaster or drywall to fall, glass in windows to break and movement in the foundation system.
- Dust masks are required for anyone mixing concrete.
- Be aware of underground pipes and wires when digging and crawling around. Damaging them can turn a safe environment into a dangerous one.

## GIRDERS

A girder is a horizontal beam used as a main support for a structure. It is held up by piers, and supports the joists in the floor system.

To build a girder, you will need the following items:

- Tools: hammers, caulk guns, circular saw, tape measure, dry line
- Materials: 2x8s, ½" OSB, construction adhesive, 12d or 16d nails, hurricane straps, shims, 2x4s for temporary piers, 3" wood screws, 1.5" nails or screws

### CONSTRUCTING THE GIRDER

NOTE: If within 18" of the ground, pressure treated wood is recommended

1. Determine length of girder and appropriate materials. Use full lengths of lumber if possible. If the girder will be over 16' in length, consider supporting the structure with 2 separate girders.
2. Check and make sure that the floor joists to be supported are all even and will touch the girder. If not, they will need to be shimmed or sistered onto in order to be supported. Do not notch the common joists as this will weaken them.
3. Rip 7" wide OSB strips down the 8' length. These will be used as the center of the girder.
4. Seams should always be staggered in construction. If using multiple 2x8s on a single side of the girder, make sure that the seams will not line up with either the OSB seams or those on the other side of the girder.
5. Using construction adhesive, glue one side of the girder to the OSB, and then flip over and glue the other side on. Make sure that the top of the girder will be completely even along the length of the girder. This can be done by holding a string taut from one end to the other.
6. Screw or nail the girder together. Place three screws on each end, and then follow screw pattern illustrated. If using pressure treated wood, use fasteners approved for pressure treated wood.

### INSTALLING THE GIRDER

1. Get the girder in place under the house; it should run perpendicularly to the joists. This can be a bit tricky, so plan ahead accordingly. You may need to build it in place.
2. Brace up against the floor joists, supporting temporarily with 2x4s. Watch out, it will be heavy, so make sure to use caution and enough people to hold it in place. See illustration.
3. Attach one hurricane strap between every 3 floor joists and the girder. Use at least 8d nails or screws to fill the holes on the straps—filling at least 3 of the holes. *If the girder is made from pressure treated wood, use fasteners approved for pressure treated wood.*

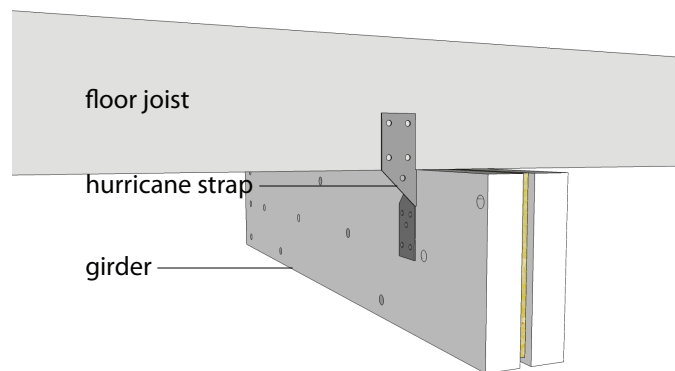
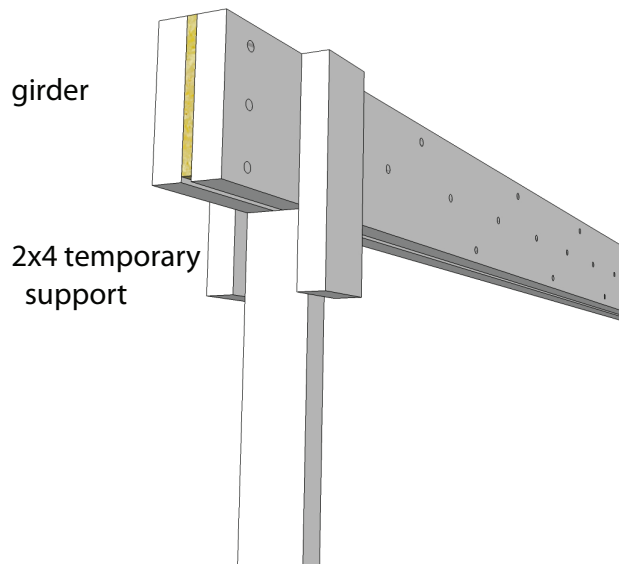
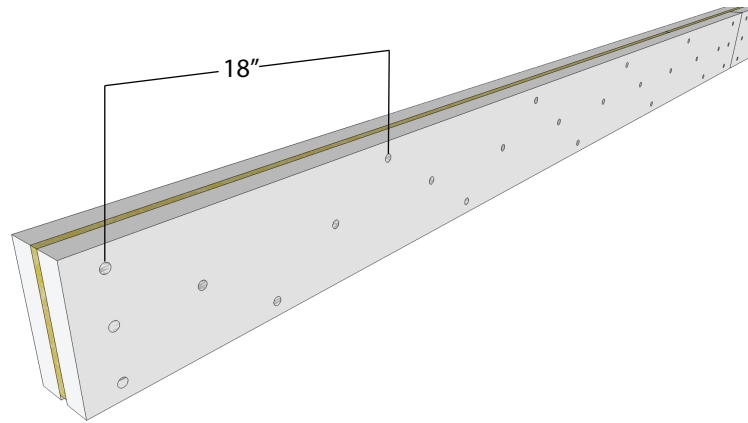
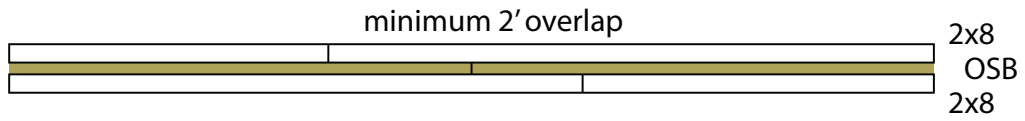

## PIERS

A pier is a vertical support that holds up a girder.

To construct a concrete pier, you will need the following items:

- Tools: hammers, shovels, wheelbarrow, hoe, levels, plumb bob, hand saw, drill, drill bits, utility knife, hack saw, tape measure
  - Materials: 8" Sonotube, concrete mix (about 7, 60 lb bags for 4' Sonotube and base), 12d galvanized nails, scrap 2x4 (bracing), duct tape, rebar, 4x4s, concrete mix, galvanized T-plates
1. Determine the placement of the piers directly under the girder. They should be spaced no more than 8' apart from one another. Hold a plumb bob on the girder, and mark where it touches the ground to make sure that the pier will be placed directly underneath the girder.
  2. Mark where the hole needs to be. All piers require a 16" x 16" x 16" (L x W x H) hole. Dig the hole. The concrete needs to be no more than 8" thick in the bottom of the hole. Fill the rest of the hole up with dirt.

### *SONOTUBE PIERS*

1. Cut a saddle into the top of the Sonotube, about 3" in depth.
2. Also cut a door into the Sonotube about 4"x4". This should allow you to fill the form with concrete.
3. To get the height of the pier, measure from the bottom of the girder to ground level, not the bottom of the hole, and add 8". Cut your Sonotube to this height. The base of the hole needs to be at least 16" across and the concrete needs to be no more than 8" thick in the bottom of the hole. The assembly will look like an upside down mushroom.
4. Hang the form from the girder, using duct tape, or brace it in place with scrap wood on the worksite. Double and triple check that you have the form plumb, and the saddle is snug against the girder.
5. Mix concrete, and begin filling the hole with concrete. When you have filled the hole halfway to the bottom of the form. Continue filling the hole until you reach the bottom of the tube, and begin filling the Sonotube through the door that you cut. Do this slowly, and tap the tube as you fill it to compact the concrete and get the air out of it. When you reach the door level, tape it closed, and fill the rest of the form through the top. If the sonotube is close enough to the exterior a trough can be made to slide the concrete into the trap door from the outside. An old piece of gutter works well for this purpose. The concrete needs to be a bit looser to slide down the trough.
6. Backfill the hole after the concrete has set for 4 hours. Tamp down the dirt as you fill in the hole, compressing the dirt tightly.

Sonotube

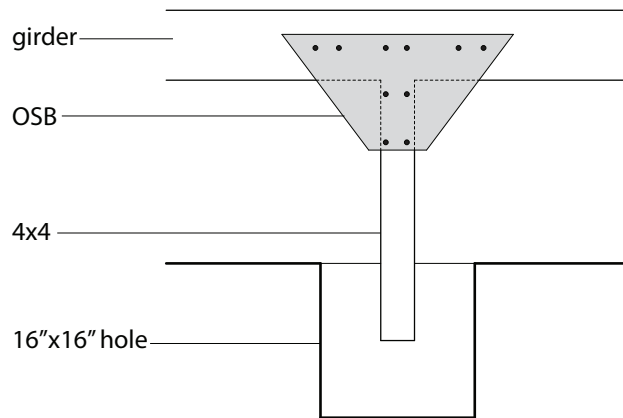
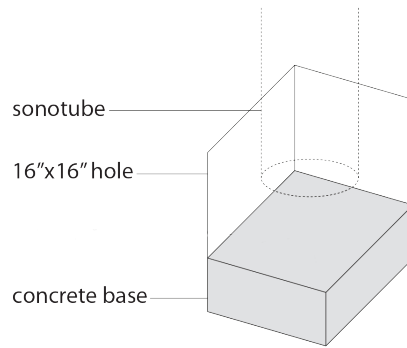
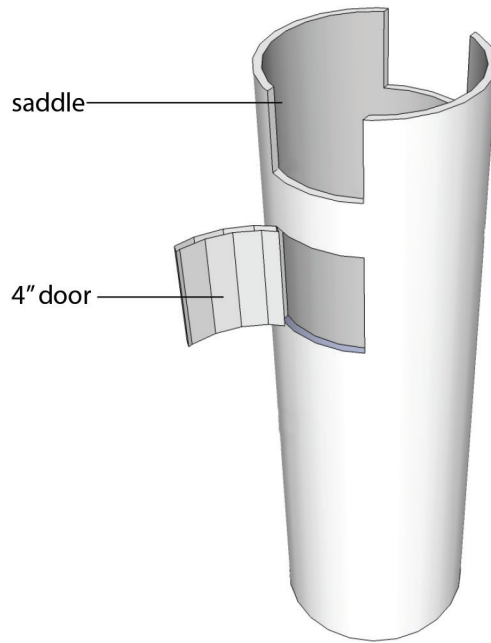

## WOOD PIERS

NOTE: 4x4s can be used up to 60" above ground level, once above this, use 6x6s\*.

1. Measure the distance to the ground level, not the bottom of the hole, and add 8". Cut your posts to length.
2. Create gusset plates to attach the girder to the 4x4s. Gusset plates can be made of OSB, cut into the shape of a triangle. The top should be 12", the bottom 6", and it should be 12" high. Glue to the girder with construction adhesive.
3. Hang the pier from the girder using the gusset plates, or approved connections (ask at your hardware store). There should be a plate on either side of the pier. Use galvanized nails or screws to attach to the pier first, and then attach to the girder, checking several times to make sure that you are installing the pier plumb.
4. Mix concrete, and begin filling the hole. Fill the hole until the concrete hits the bottom of the post. The post should rest on the concrete.

## PIER AND GRADE BEAM FOUNDATION

Some new additions will have a pier and grade beam foundation, also called a perimeter foundation, or a pillar system.

The plan calls for digging holes for piers, building a wooden form on top of the ground, laying rebar, and filling with concrete in a single pour.

Addition sizes are standard:

- Bathroom - 8'x8'
- Bedroom with closet - 8'x12'
- Bedroom with bathroom - 8'x20'
- Double bedroom - 8'x24'

Things to consider before beginning a room addition:

- Is it really needed?
- Can the family afford the increased utilities cost?
- What does the finished floor height need to be?
- Does the land allow for an addition?
- Is there anything in the way of the addition? Septic, trees, hills, boulders, etc.
- Is there sufficient electrical service for the additional load on the house?

---

\* If using a 6x6, you can notch the top of the post to hold the girder. See illustration.

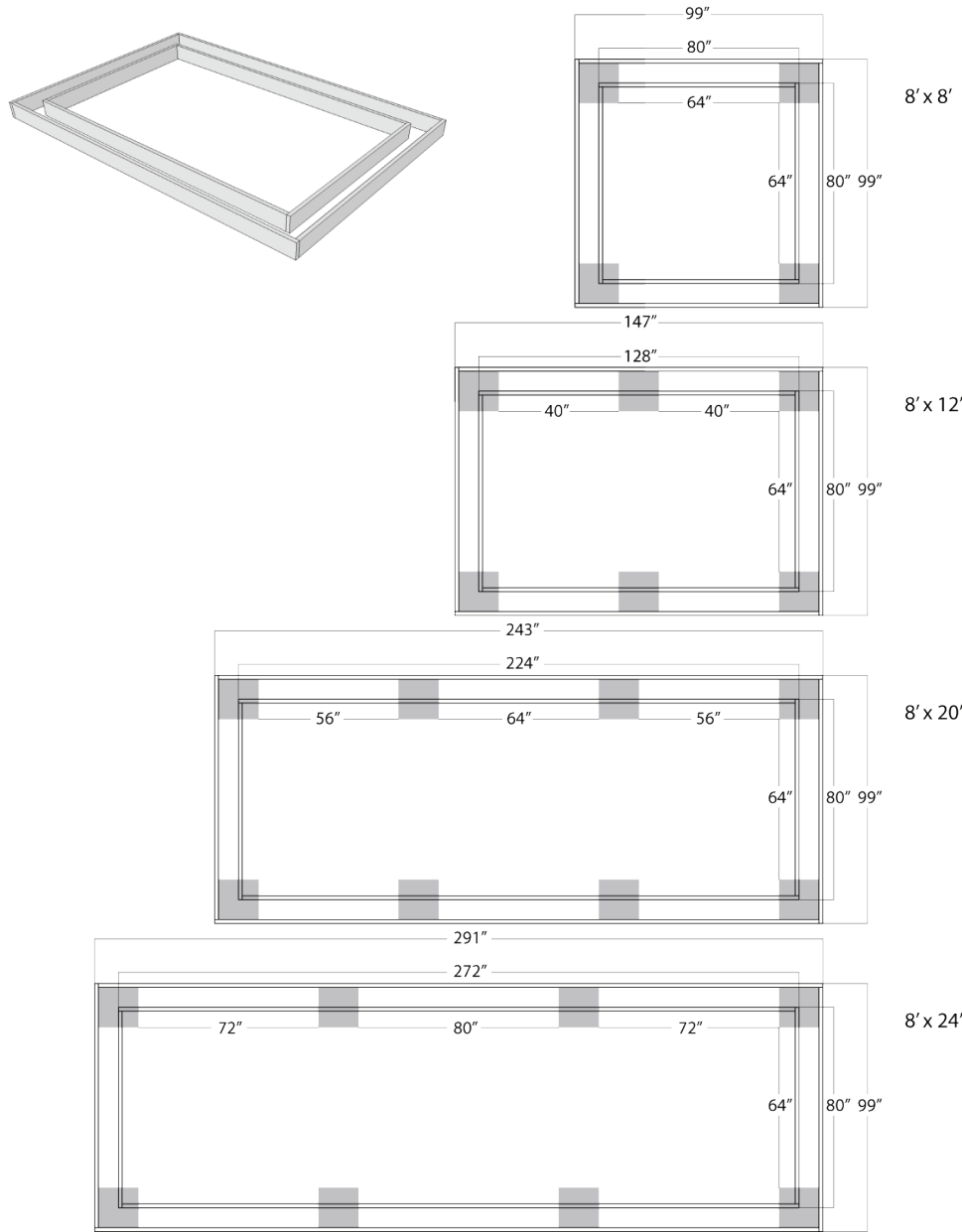
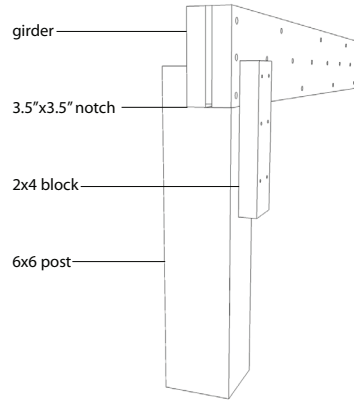

1. Determine size based on usage and location of the addition.
2. Layout the foundation, making sure to have all utilities marked prior to digging.
3. Dig pier holes at least 16" deep and 16" wide. One of these will be at each corner, and spaced out along the longer walls. Pier holes should be placed no more than 8' apart. Space the piers equidistant from one another along the sides. See illustrations for exact placement.
4. Build wooden form out of 2x8s on the ground above the holes. The top of the form needs to be level. You may need to dig into the ground to level out the base of the form. Do not dig in more than 2". If the slope of the ground is too steep and digging in will cause problems, you can also add OSB to the bottom of the wooden form, allowing it to sit level above ground level. The OSB will keep the concrete in the form, but allows for some adjustment. Whatever you may need to do, make sure that the piers will be at least 16"x16"x24" below grade.
5. The measurements of the form must be adjusted for the width of the lumber you are using to create the frame. The outside form is 3" wider than the desired finished size, and the inside form is 16" smaller than the desired finished size. See illustration.
6. The inside and outside form must be leveled and squared. Allow for at least an 8" wide trough to fill with concrete. It is very important to check in several places across and around the form before pouring any concrete. Use 2x4 scraps to screw across the top of the form to keep it all in place once you have determined that the form is ready for use.
7. Rebar placement is crucial to the structural integrity of the foundation.
8. Cut 2 sticks of ½" (#4) rebar for each side of the form. The rebar should be 4-5" shorter than the side of the form, as it is important to leave 2-3" between the rebar and the surfaces of the concrete. If a side of the form is longer than your rebar, tie two sticks together with rebar ties, allowing for a 6" overlap.
9. Place rebar horizontally inside the form. The two sticks within a side should be 2-3" apart from one another, and 2-3" away from what will be the surfaces of the concrete. Support the rebar 2-3" above ground level with rebar chairs (made either of plastic or an approved steel) or with bricks. Tie all intersections with rebar ties, making sure that they are secure.
10. Two sticks of rebar also need to go down into each pillar. They can be pounded into the ground and positioned to tie into the horizontal rebar sticks.
11. Anchor bolts need to be placed in the form. Anchor bolts will let you anchor the sill plate directly to the foundation. There are a variety of anchor bolts; ASP typically uses J bolts, thus the following steps. The bolt needs to extend 2.5" above the top of the form. Use 2x4s with holes big enough to fit the J bolt through in order to float the bolts while pouring concrete. Anchor bolts should be placed 8" from each corner, and every 6' along the foundation. For foundation lengths requiring multiple pieces of lumber for the sill plate, place an anchor bolt 6" on either side of the seam.
12. Mix and pour concrete all at once. Concrete should be mixed to the consistency of chunky peanut butter, or thick oatmeal. Either use a small cement mixer, or have the foundation poured. Be careful not to knock the rebar around; if this happens, just reposition and continue pouring.
13. After the foundation has set for 24 hours, the form can be dismantled and reused, or used for floor joists in the addition.



Rebar frame

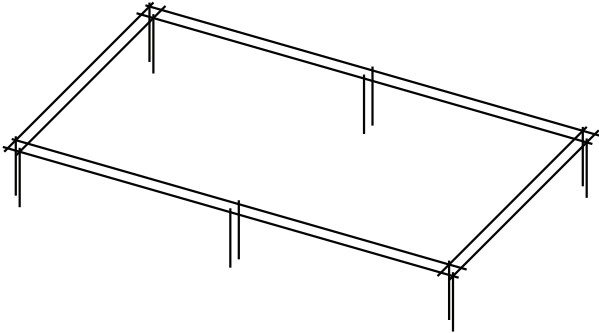

Connecting vertical and horizontal rebar

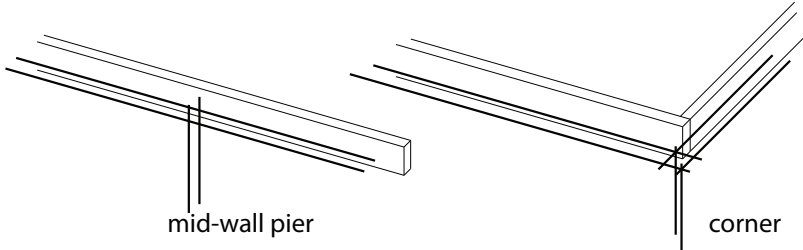

2x4 layed across 2x8 frame

J bolt

rebar running 3" from bottom

2x8 frame

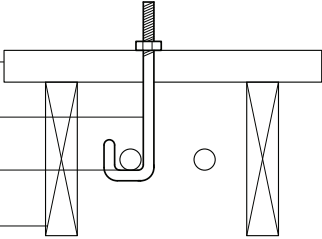

Completed foundation frame

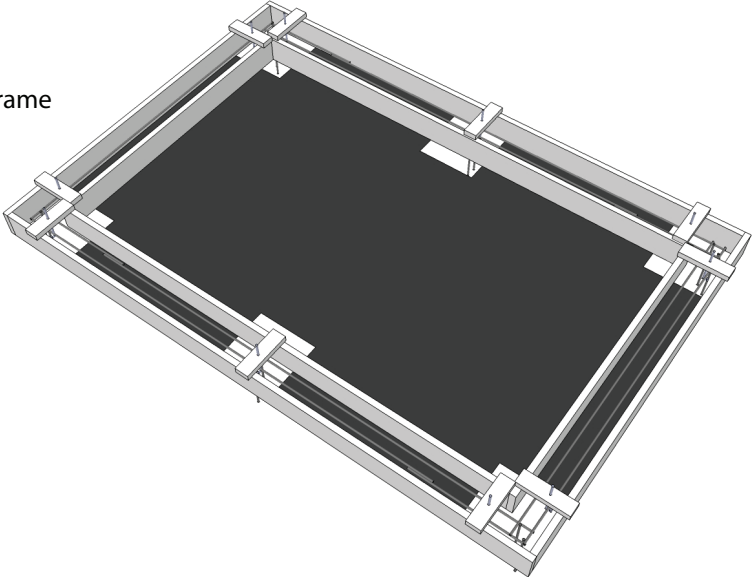

stepped form

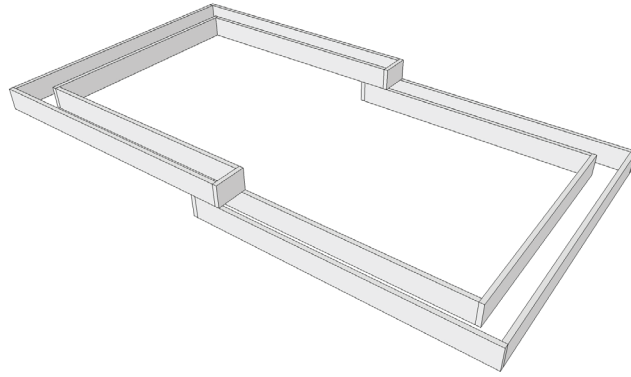

stepped form with OSB in place

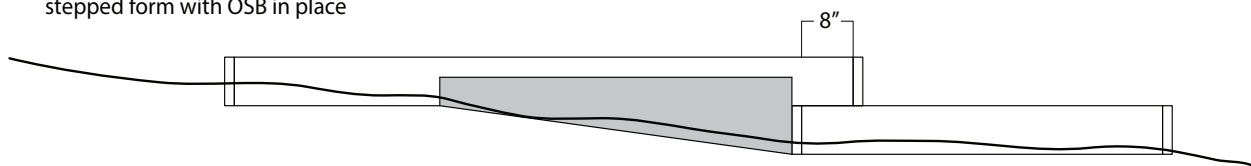

rebar placement in stepped form

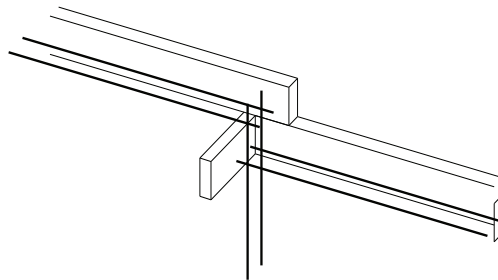

# FLOORS

## SAFETY

Dangers while working on floors:

- Walking on joists. Temporarily tack sheets of OSB to the joists. Safety first!
- Insulating the floor should be the very last thing to happen before the subfloor is nailed down. Insulation will often give people a false sense of security, causing them to put a foot through.
- Use of a reciprocating saw is often required while removing a floor. Make sure the area is well-lit and clear of people and clutter. **Everyone** in the room should use earplugs.
- Make sure circular saws are being used appropriately.
- Long sleeves and masks should be worn by everyone working with insulation.

| FLOOR JOIST SPAN DATA |                              |                                   |  |
|-----------------------|------------------------------|-----------------------------------|--|
| NOMINAL JOIST SIZE    | SPACING IN INCHES ON CENTER* | MAXIMUM ALLOWABLE SPAN            |  |
|                       |                              | MEDIUM GRADE SOUTHERN YELLOW PINE | SOUTHERN YELLOW PINE WITH DRYWALL ATTACHED |
| 2X6                   | 16"                          | 9'4"                              | 8'0"                                       |
| 2X6                   | 24"                          | 8'1"                              | 6'6"                                       |
| 2X8                   | 16"                          | 12'3"                             | 10'6"                                      |
| 2X8                   | 24"                          | 10'3"                             | 8'9"                                       |
| 2X10                  | 16"                          | 15'5"                             | 13'8"                                      |
| 2X10                  | 24"                          | 12'7"                             | 11'4"                                      |
| 2X12                  | 16"                          | 17'10"                            | 16'2"                                      |
| 2X12                  | 24"                          | 14'7"                             | 12'4"                                      |

## FLOORS

A floor consists of the following components:

- Sill plate: a component that ties the floor system to the foundation. All wood that is in direct contact with concrete must be pressure treated. (A lot of times in Appalachia there will not be a sill plate.)
- Band joist: a component of the box joist that runs perpendicular to the common joists, holding them in place and stiffening their ends. The band joist usually supports a load bearing wall. There is typically a double band joist on pier foundations, and a single band joist on continuous foundations. Some call this the rim joist also.
- Rim joist: a component of the box joist that runs parallel to the common joists and ends the floor system. Typically there is a double rim joist on pier foundations, and a single rim joist on continuous foundations. This is also referred to as a band joist.
- Common joist (or joist): a component of the floor system that carries the weight of the interior of the house. They run from the exterior of the house toward the center girder or from exterior to exterior, typically centered at 16" or 24". Joists must be sized according to the span chart.
- Subfloor: also referred to as decking, the subfloor is the sheathing that forms the actual surface of the floor.
- Finished floor: this constitutes the actual floor that you walk on when it is all said and done. The finished floor includes any leveling that you perform before laying the surface material.

## FLOOR FRAMING\*

### *BUILDING A NEW FLOOR*

Determine size of lumber. Use the span chart to do so. The band, rim, and common joists will all be the same nominal dimensions.

### *IF CONTINUOUS FOUNDATION*

1. Anchor the sill plate, treated 2x6s, into the continuous foundation. If you have built the foundation, there should be bolts sticking up to anchor into. If not, you will need to find another fastener to do so (such as concrete tapping screws). The sill should be bolted 8" in from each corner, on either side of a joint and a maximum of 6' between bolts.
2. Once the sill is in place, you can begin constructing the floor system itself. Install the band joists first, and then rim joists. The rim joists should sit inside the band joist, the same way that the common joists will.

### *IF PIER FOUNDATION*

1. Connect sill plate to piers. Piers should be a maximum of 8' apart.
2. Construct a box joist. The box joist is constructed by joining the rim joists on the inside of the ends of the band joists, forming a box. The box joist sits on top of the sill plate, and is connected with nails and metal straps.

---

\* Floor Joist Span Data appears on the previous page

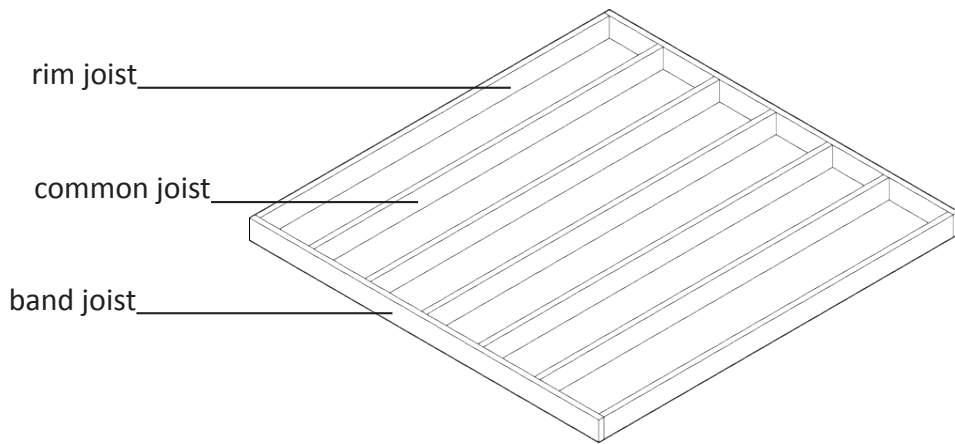

Box joist example

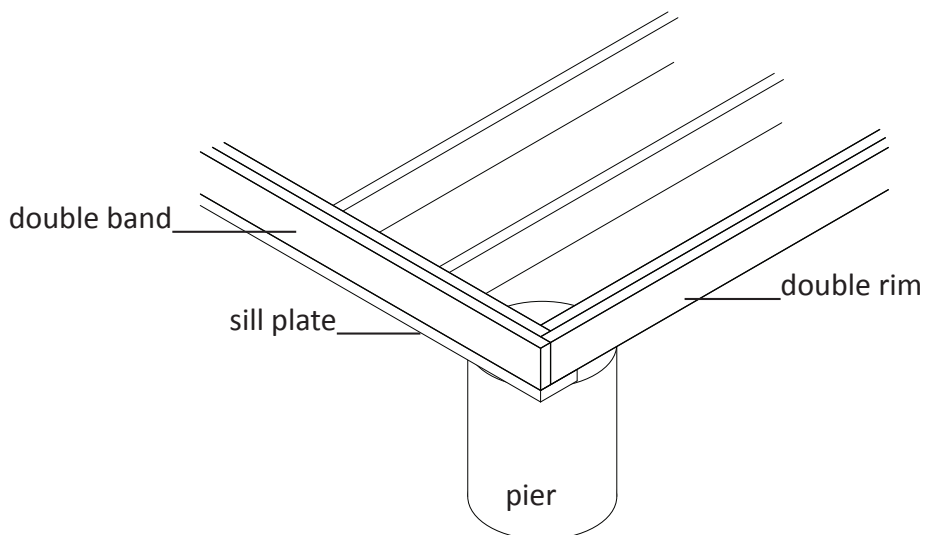
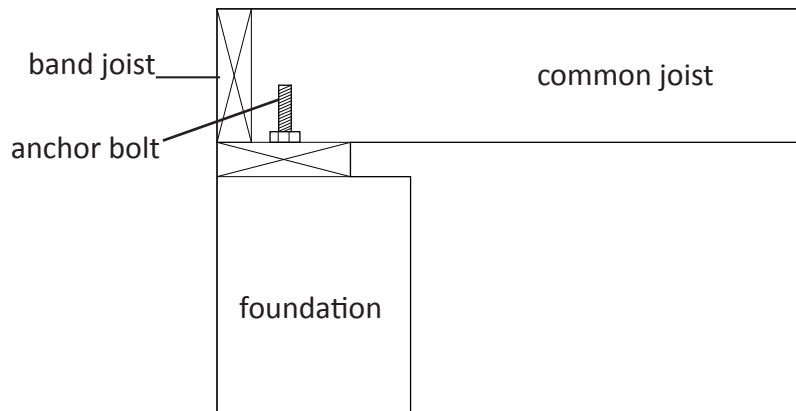

3. Mark the band joists for the common joists at 16" on center (OC). Joists are attached by toe nailing the common joist into the band joist, or nailing through the band joist into the ends of the common joists.
  - When installing joists, always install them crown up. All boards have a slight bend to them; this is called the crown.
  - When installing floor systems, consider the placement of load bearing walls. Load bearing interior walls must be supported by the floor system. There should be a girder/pier system under interior load bearing walls. Load bearing walls carry the weight of the roof system. Generally, the load bearing wall runs parallel with the ridge.
4. With the floor framing completed, the floor is sheathed, and then walls built on top of the sheathing.

### **JOIST REPLACEMENT/REPAIR**

Many times, joists will be sagging, cracked beyond repair, or have significant rot. In these cases, it is better to simply replace the joist itself, rather than attempting to perform several repairs.

#### *HOW TO REPLACE A JOIST*

1. Check the existing lumber dimensions to make sure that you are replacing the joist with the same size lumber. It would be worthwhile to then compare this against the span chart to see if the lumber used is actually the correct size. Since the joist(s) is(are) broken, it is an indication that something is wrong, and you may need to install a girder to prevent future problems.
2. Remove the subfloor if necessary. See the subflooring section for specifics. You can also work from under the floor itself. This is the preferred method.
3. Install the new joist next to the one you are replacing, making sure to crown the board. Attach to the band joists with joist hangers. If there is a sill plate or ledger, set the joist on top of them and nail into place, using 12d nails, 2 going down into the ledger/sill, and at least 2 going into the band joist.
4. Remove the broken joist and replace it with a new one.

#### *HOW TO REPAIR A JOIST*

If the joist has rot less than a third of the length of the board, or is slightly cracked, you can simply repair the joist with a process called scabbing.

1. When attaching new lumber to old that has rot, wrap the new wood with waterproof material such as roofing felt, synthetic underlayment or house wrap to prevent rot transfer to the new lumber. This is called flashing. Metal flashing is not required and is harder to work with.
2. To reinforce a common joist which has rotted or cracked, use the same size lumber to scab onto the existing floor joists. Extend the scab at least 2' past either side of the problem area. The scab should be placed on either side of the joist.
3. The scab should fit as tightly to the bottom of the subfloor as possible. If the floor has significant sag, place the scab as high on the joist as possible. Scabs can often be used to dramatically correct the slope or level of the floor. Usually the floor can be lifted to take much of the bow out.
4. Attach scabs using nails or screws that are at least double the thickness of the scab. Usually a 3" wood screw or 12d nail will suffice.

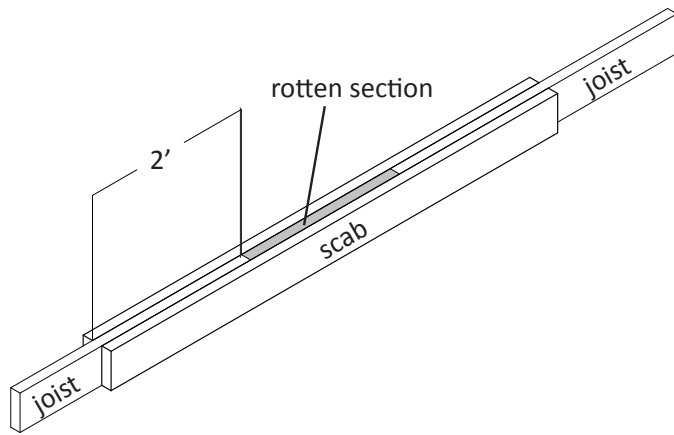

## BAND/RIM JOIST REPAIR

To repair or replace the band/rim joist, the weight of the house must be taken off of the section that you want to work on. **Always use pressure treated lumber.**

1. To temporarily support the common joists, place a 4x4 perpendicularly underneath the joists affected by the removal of the band joist and apply a minimum amount of pressure with a bottle jack. Keep the jack as close to the common joists as possible.
2. You may need to set the jack up on concrete block. Set the block on a level surface, such as a 2x8, and then place a 2x8 in between the jack and the block in order to create a larger bearing surface.
3. After supporting the floor, support the wall by installing kickers. Kickers are temporary supports installed outside the house that run diagonally from the top of the wall to the ground. Kickers can be attractive to children, so warn both kids and parents that they are not to be played with.
4. To install kickers, place a 2x4 ledger as close as possible to the top of the wall and the bottom of the rafters. You want to be able to fasten the 2x4 into the studs of the wall and catch the weight of the rafters as well. Remove the siding if possible to prevent damage. Fasten the 2x4 with 12d nails or 3" screws, making sure to hit the structure of the wall, not just the sheathing.
5. Install the 2x4 kickers perpendicular to the wall at an angle of 4:1 so that for every 4' of height the kicker is positioned 1' out from the wall. Attach the bottom of each kicker to a 2x4 stake driven into the ground at least 24". Use screws to do so. The kickers should be tight between the ground and the 2x4 on the wall so that they actually take the weight of the wall and do not let the wall drop when the band/rim joist is removed.
6. Place kickers every 6'-8' along the wall. If the ground is soft, or if the wall is to be supported for several days, use additional kickers.
7. Once the kickers are installed, remove the damaged or rotten sections of the band/rim joist. Do not remove more than 8' at a single time, as this can cause more structural damage to the house.
8. Replace the removed band/rim with the appropriate sized lumber. The ends of your new lumber should fall on the ends of a common joist. Attach into the ends of the common joists with 3-12d nails. To connect the new band/rim to the old, install steel plates at both ends of the new band/rim to connect the new section to the old. Install at least a 4' section of rim/ band joist. **Always use pressure treated lumber.**
9. If the wall needs to be raised due to collapse/absence of the band joist, jack the wall slightly to slide the new joist into place. See staff before jacking any wall.



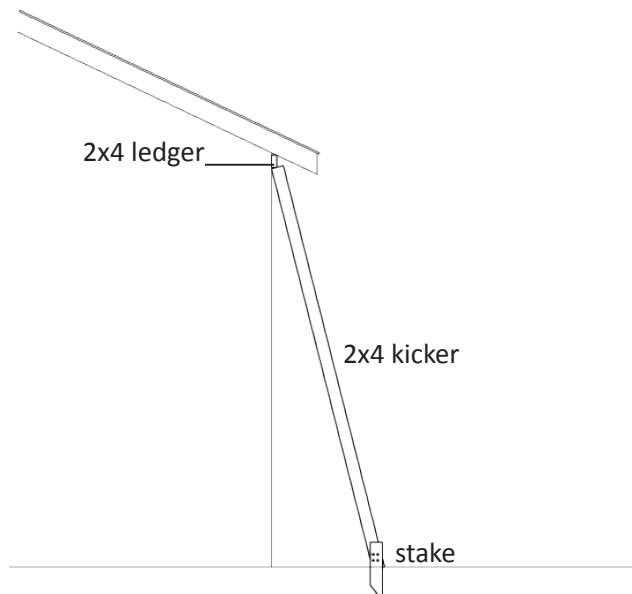
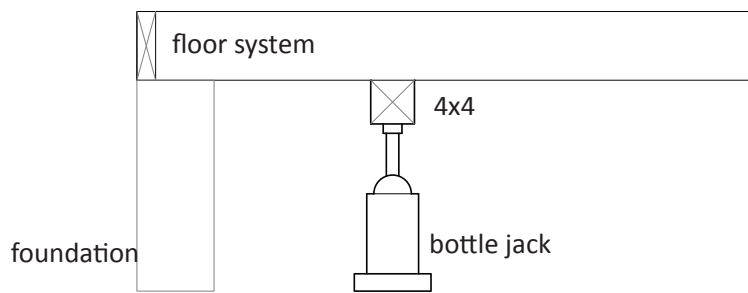
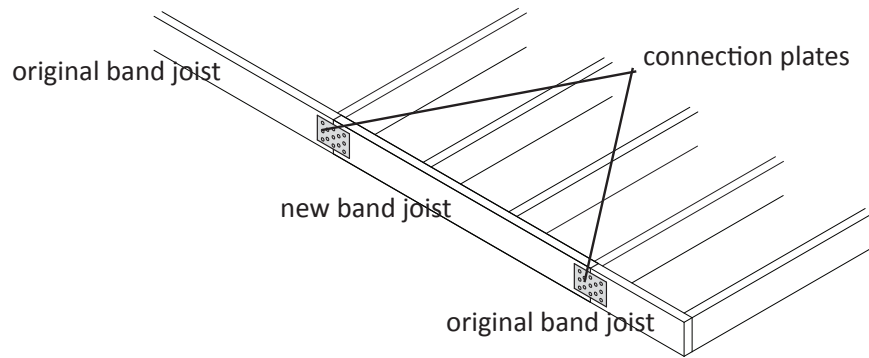

## **BRIDGING/BLOCKING**

Bridging is a type of bracing installed between joists to increase a floor's stiffness while holding joists in place and helping prevent joists from twisting. Bridging should be the same size as the joists in the floor system.

Bridging should be used when floor joists span more than 8' without being supported by a girder, or over a girder that you install.

Blocking is similar to bridging, only it can be use to shore up a smaller area of the floor. A good place to use blocking is underneath a toilet to provide more support, under the long edge of a tub, or at the edges of cabinetry.

## **STIFF-BACKS**

Stiff-backs are commonly used to limit floor deflection. Floor deflection is the tendency for a floor system to bounce or bend under pressure. These are good to use if the floor seems to bounce a little bit when you jump up and down. If it bounces a lot, or moves simply when you walk, you want to consider a girder.

1. A stiff-back is made of a 2x4 and a 2x6 fastened into an L shape and attached perpendicular to the floor joists.
2. Stiff-backs are typically installed at the center of the floor system, but multiple can be used if they are evenly spaced underneath the floor system. Three inch screws work the best, since you are working underneath a house.

## **SUBFLOOR**

Subflooring is typically made of ¾" tongue and groove (T&G) OSB. Floors in older homes may be made of 1x6 planks; floors in mobile homes are usually made of composite pressboard.

1. Lay the OSB perpendicular to the common joists. Each sheet of OSB should span a minimum of 2 joists, with edges always landing on a joist so that it can be nailed in and supported.
2. Stagger the short seams of the OSB by at least 2 joists width.
3. Cut any necessary holes into the OSB, including cables, toilet flange, plumbing, vents, etc.
4. Run a ¼" bead of construction adhesive on each joist prior to laying the sub-floor.
5. Use 8d ring shank nails, 8d sinkers/coated, or 2" screws to attach each sheet of OSB every 8" around the perimeter and every 12" along the interior.

*Notice the staggering*

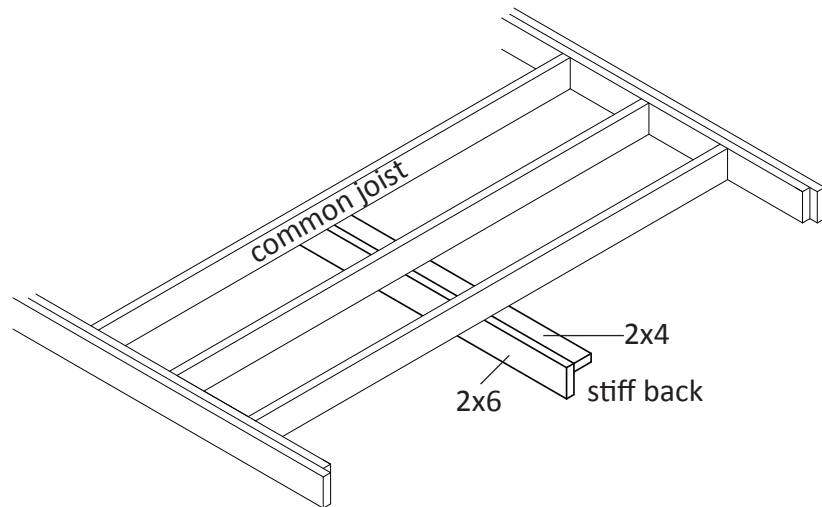
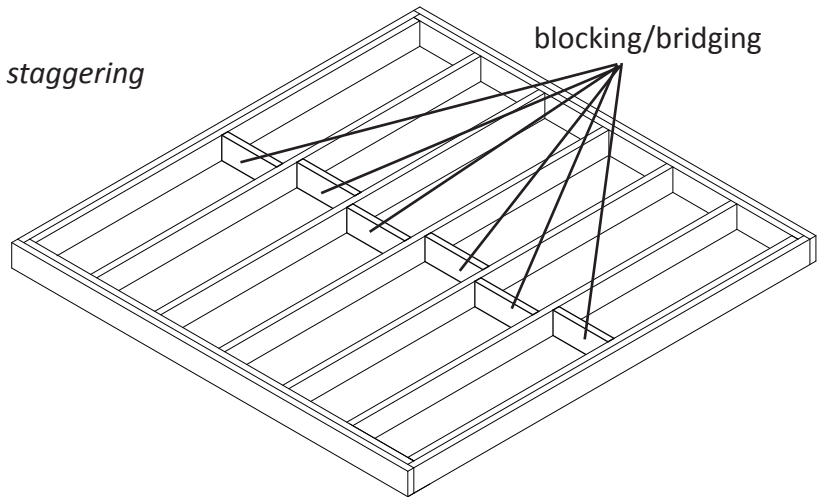

## *SUBFLOOR REPAIR*

Subflooring often needs to be removed to investigate, repair, or replace framing members. When repairing subfloor, it is tempting to just replace the section that needs it; however, this will often lead to a floor made up of lots of small pieces. Instead, try to use full or half sheets when replacing subfloor, and think about where the seams are going to fall (it is better if they do not fall in areas of high traffic such as down the middle of a hall, at the front of a toilet, etc.).

1. Use a chalk line to mark the section of floor to be removed. Use a carpenter's square as well. The more square your removal, the easier it is to install a new piece of subfloor.
2. To safely remove subfloor, set the depth of a circular saw to that of the sub-flooring and cut parallel to the joists and within  $\frac{3}{4}$ " of a joist. Cut as close to the wall as possible. You may have to use a hand saw (or toe kick saw if available).
3. Always wear safety glasses, and N-95 dust masks, when cutting the subfloor, because of the risk of hitting nails with the saw or hazards that may be in the sawdust.
4. Always try to replace full 4'x8' sections of subfloor. If your new subfloor is T&G, you may need to remove the tongue in order to get it to fit in the hole that you have left for it.
5. When replacing the damaged subfloor, add 2x4s (nailers) along the sides of the joists that the new piece will land on. The nailers should be flush with the tops of the existing joists to allow the subfloor to sit evenly with the rest of the floor. Attach these with (2) 12d nails or 3" screws every 8".
6. Lay the subfloor. You want the seams to be tight and close together, not gaping and not allowing light through.

## **FLOOR COVERINGS**

There are a plethora of different types of floor coverings; we will focus on using just a few here at ASP. If a family requests carpet, inform them that you cannot provide them with carpet. We have stopped using carpet because of health concerns; it is hard to clean, promotes asthma in children, potentially releases chemicals, and has a short lifespan. You will use vinyl composition tile (VCT), laminate flooring, or vinyl planks. If you are experienced with laying ceramic tile, feel free to do so.

### *VCT (VINYL COMPOSITION TILE)*

VCT is a 12"x12" square tile that is typically laid in large institutions, such as schools and office halls. It is laid over a smooth surface using a specialized adhesive that never fully dries. If installed properly, it is a resilient flooring material that can easily be repaired and last for years. We use water soluble glue. It cleans easier and does not release harmful gasses during installation.

VCT is not the same product as peel and stick tile. Peel and stick does not have the sustainability that VCT has.

We are using three different types of underlayment to prepare the subfloor for VCT.

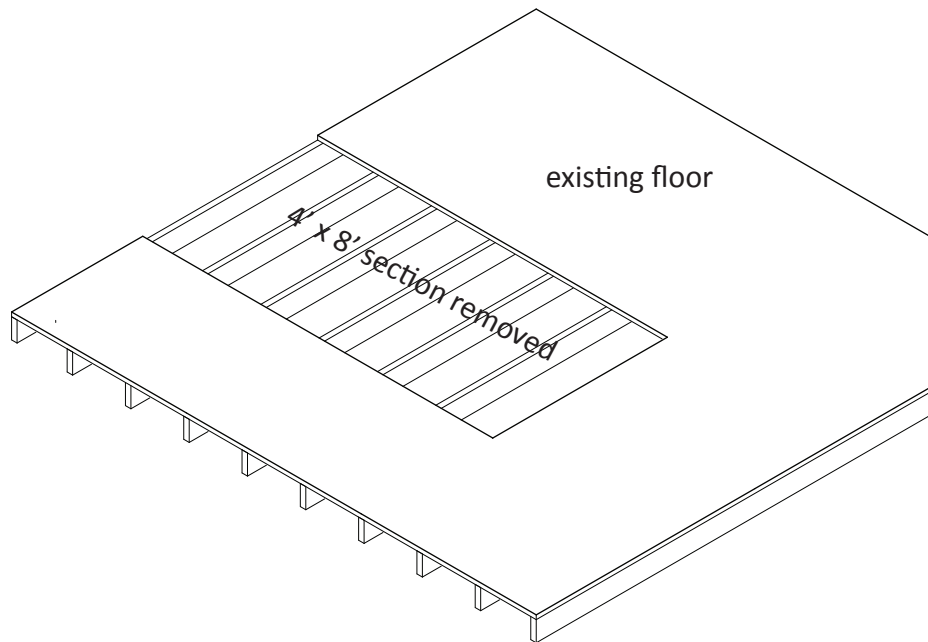
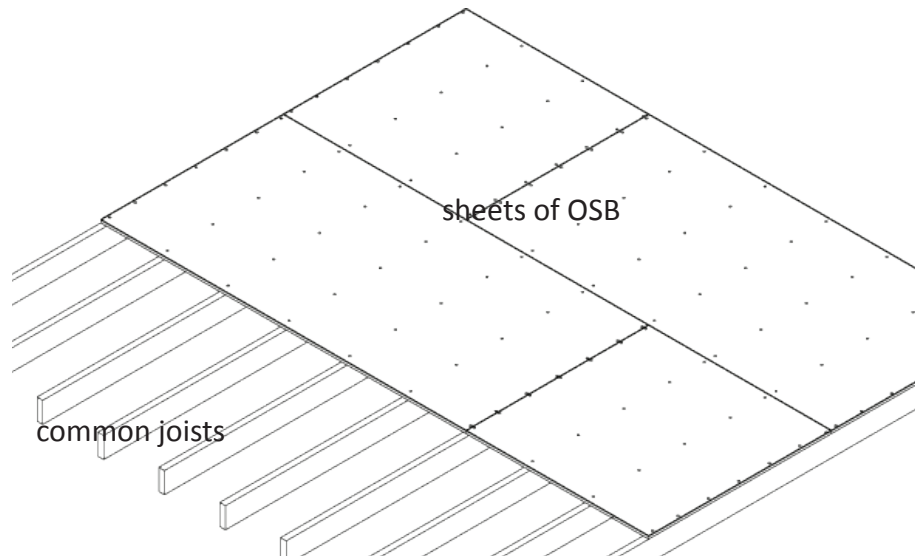

## *LUAUN*

One type of underlayment is luaun (  $\frac{1}{4}$ " or 5mm plywood).

1. Before installing luaun, sweep the sub-floor and make sure that the area is free from dust and debris.
2. Install luaun perpendicular to the subflooring, staggering the seams so that they do not line up with seams in the subfloor, and also so that the short seams are offset at least 2'.
3. The luaun should be fastened every 6" along the perimeter and every 12" along the interior. Use underlayment nails (large head, ring shank nails approximately 1" in length), or use screws installed with a dimpler bit.
4. Once installed, run a putty knife over all nail heads to check that they are sunk far enough. If the knife catches on a nail, it needs to be driven in further.
5. Cover all seams and nail heads with floor leveling compound. Mix the compound to a consistency described on the mix itself. Mix in small batches, and apply with putty knives; it dries quickly. Once the leveler is dry, scrape or sand until smooth. The more you use, the more you have to sand. Wear masks and goggles when scraping and sanding.

## *FLOOR LEVELER*

A second way to prepare the subfloor is with a floor leveler with a bonding additive. There are many products out there, just ask your hardware store to find the correct one for your project.

1. Mix product according to manufacturer's directions. They are self-leveling, so if mixed to the right consistency, little scraping and sanding should be necessary.
2. Scrape and sand any imperfection after the product has dried. The floor is ready for VCT.

## *HARDIBACKER*

This product is used in wet areas like bathrooms, laundry rooms, etc.

1. Sweep the subfloor to clean it completely
2. Lay the sheets (3'x5') perpendicular to the subfloor
3. Follow manufacturer recommendations about fasteners to use and placement of fasteners. There are indented spots on the hardibacker to receive the fasteners
4. Check that all screws are below the surface level of the floor

luaun is attached every  
6" along perimeter &  
12" along interior

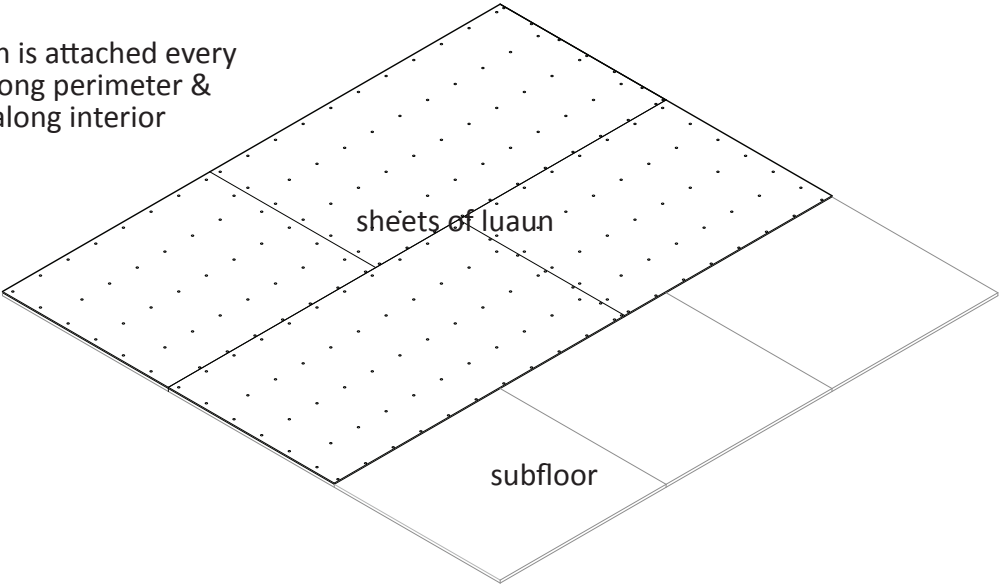

## INSTALLING VCT

Note: You will use a 1/8" to 3/32" notched trowel to spread the adhesive. Read and follow directions on container of adhesive. **VCT ADHESIVE MUST CURE BEFORE APPLYING TILES. CURE TIME VARIES BETWEEN ½ TO 2 HOURS.** Door casings and jambs may need to be trimmed to allow VCT to slide under.

1. Before starting installation, be sure that the room is clean. Try not to track anything on your underlayment or floor leveler. (Be sure all fasteners are not protruding from underlayment)
2. Determine where to start tile. (Many will chalk lines from the center of each parallel walls to determine center of room and start there.) We are going to use another method that focuses on the sightlines from the entryway into room. Measure to middle of doorway from wall and make a mark, then use this same measurement to make a mark the same distance from wall, on wall parallel to doorway. Snap a chalk line between these marks. Measure to middle of adjacent wall and make a mark. Use same measurement on parallel wall and make a mark. Snap a chalk line on these marks. This should leave you with 2 lines that intersect each other, take care that these lines are square.
3. Once both chalk lines have been snapped you have created 4 quadrants of the room. It best to start on section furthest from the door. *Note: You will be applying glue away from the wall, then installing tile to the wall.*
4. Keep a rag and bucket of warm water handy to clean up excess glue on tile, yourself, and your tools. Clean any excess immediately.
5. Using a 1/8" to 3/32" notched trowel apply a thin layer of VCT adhesive in the first quadrant. Hold trowel at a 45 degree angle, using figure 8 motions to spread the adhesive evenly on the quadrant of the floor. The notches will create peaks and grooves. The grooves will be so thin that the floor is still visible. Be sure that the adhesive is spread relatively even and in a thin coat.
6. **WAIT UNTIL ADHESIVE SETS. CURE TIME VARIES BETWEEN ½ HOUR AND 2 HOURS. ADHESIVE WILL HAZE OVER AND BECOME TACKY AND ALMOST DRY TO THE TOUCH.**
7. Position first tile at the intersection of chalk lines, making sure it is square before pressing it down firmly. Lay the next tile beside the first one, along one chalk line. Butt the edges tightly together and press down firmly. Lay the third tile on the other side of the first, along the perpendicular chalk line and press down firmly.
8. Position 4<sup>th</sup> tile in corner created by other tiles. Butt both edges tightly to 2<sup>nd</sup> and 3<sup>rd</sup> tile and press down firmly. Install 2 tiles along the two chalk lines, then fill in tiles in the center of the quadrant. As you work you will move over previously laid tiles. Move carefully, the adhesive should hold tile in place (if not too much glue was spread, or has not yet set).
9. As you reach the edges, the tiles will have to be cut to fit. To fit tile to straight wall you can measure and use a straight edge to score tile with a utility knife and break them along score line. Another method is to place a loose tile (tile "a") over the last full tile in row. Over the loose tile place a full tile (tile "b") and butt it against the wall. Score tile "a" along the edge of tile "b". This method reduces error in measurements. With either method be sure to place cut edge along wall so it will be hidden with baseboard.
10. Apply adhesive and begin in 2<sup>nd</sup> quadrant. Butt up the tiles in the 2<sup>nd</sup> quadrant to tiles in the 1<sup>st</sup> quadrant. Using your chalk line and edge of the laid tile in the 1<sup>st</sup> quadrant should give you square guides to work off of. Lay tiles in the same order as you did in the 1<sup>st</sup> quadrant. This order provides edges for each tile to butt up to, ensuring gap free, square installation. Continue this process until all VCT is installed, moving from 2<sup>nd</sup> quadrant to 3<sup>rd</sup>, finally to the 4<sup>th</sup> quadrant. Only apply glue for area that will get covered with tile that day.



**11. VCT MUST BE WAXED AFTER IT IS INSTALLED.**

12. VCT adhesive needs 3-5 days to cure before cleaning and heavy traffic. Once adhesive is set, it is critical that the VCT be sealed to prevent staining and increase durability.
13. Before applying sealer be sure that floor is free from any stains, dirt, or dust. Apply sealer with synthetic pads or a synthetic mop. It's best to do several light coats of sealer to achieve long lasting quality results. Allow 30 minutes of dry time before recoating sealer.

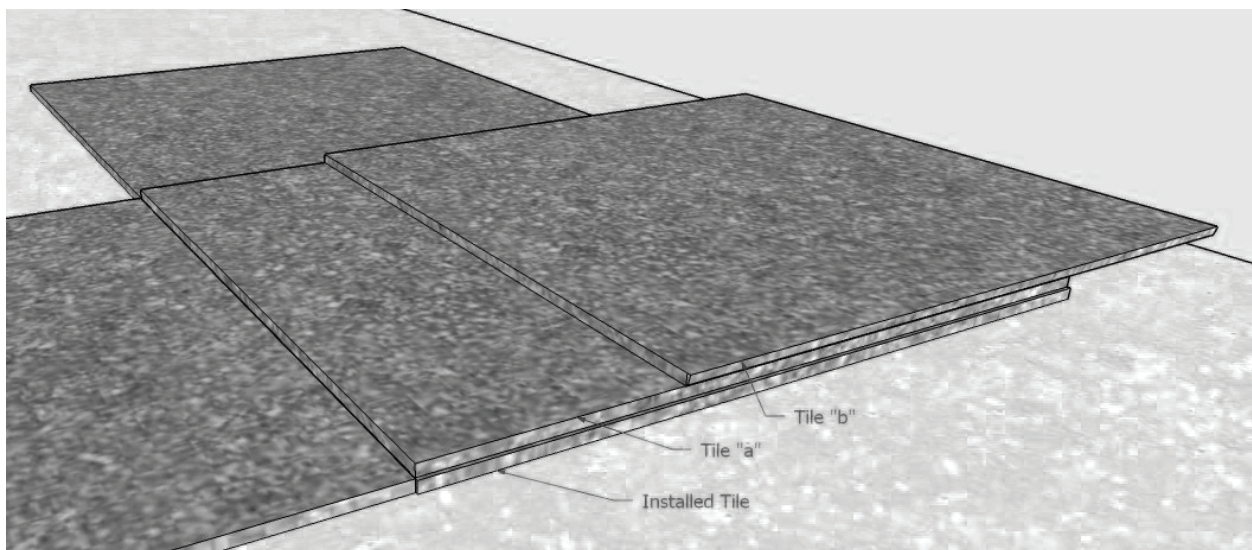
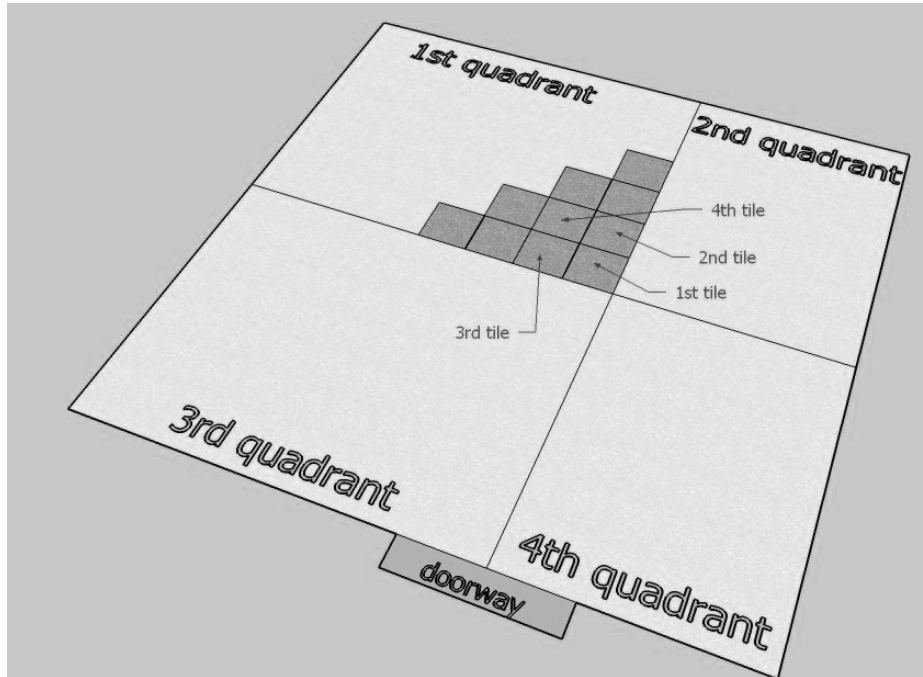

## LAMINATE FLOORING

Laminate flooring is a floating floor, requiring no glue. It has a tongue-and-groove system that clicks and locks into place. It requires a thin roll of foam to be installed over wood subfloors, as well as a vapor barrier on concrete floors. If the subfloor is in good shape underlayment is not required.

Each manufacturer has slightly different installation instructions, so make sure to double check their instructions as well.

Order 10% more flooring than expected to allow for cuts and mistakes.

1. The first step is determining whether or not the floor is actually suitable for laminate flooring. Take a 4' level and check the floor for any and all low/high points. The subfloor must not sway anymore than  $\frac{1}{4}$ " over an 8' section. If it does, floor leveler needs to be applied to the floor. If the subfloor is extremely wavy, you may want to consider another flooring product such as VCT as laminate will not work.
2. Open the flooring material up and allow it to sit horizontal and open in the room for at least 48 hours (or 72 hours if possible). This will let the flooring acclimate to the humidity and temperature of the room, and makes for better installation as well as being required by manufacturers.
3. If working on a concrete subfloor, apply a moisture barrier. This should be made of 6mm plastic with an 8" overlap at all seams. Run the plastic 4-6" up the walls and tape in place.
4. Lay the foam underpad. Each product is slightly different, but usually you roll out the product, and there is a tab that you overlap for the seams. Some have a sticky strip that you use to adhere one piece to another; if not, you may want to tape them together just to keep the underpad from slipping all over the place.
5. Inspect each board for any defects in the surface, as well as along each tongue and groove. If there are any defects, set to the side to be either discarded or cut down. Pay particular attention to the grooved side of each board when inspecting for defects.
6. Use either scrap flooring or spacers to allow for gap between the flooring and the wall. Run the flooring parallel with the longest room in the wall.
7. Take a piece of the flooring and lay it on the floor against any door jambs. Mark the height, and using a hand saw, trim the bottom of the door jamb, making sure to stay parallel with the subfloor.
8. For the first strip, use a utility knife and slice off the tongue of each piece. This tongue-less side will go against the wall. The grooved side faces out into the room.
9. Lay the first piece of flooring, with the groove facing out. Work your way into the room. This way the cut pieces will be hidden at the back of the room. Start on the wall that is closest to the door. Depending on the manufacturer, either press or tap the next piece into place (along short side). Do this across the room, until you reach the far walls.
10. Starting back at that first corner, trim at least 12" off of the left hand side of a piece of flooring. Insert the long tongue into the groove of the piece already laid, and push down into place. Make sure all seams are tight. Continue this until the room is complete.
11. The shortest length of piece should be about  $\frac{1}{3}$  the length of a board. Going shorter begins to compromise the integrity of the piece.

12. Make sure to leave that  $\frac{1}{4}$ " gap around the entire room.
13. The last row will need to be cut length wise, using a table saw. Make sure to still allow for the gap.
14. Remove all spacers. Install baseboard. It is important to make sure that you nail the baseboard into the wall, and not into the floor.

planks should be staggered by at least  $\frac{1}{3}$  the length of the board

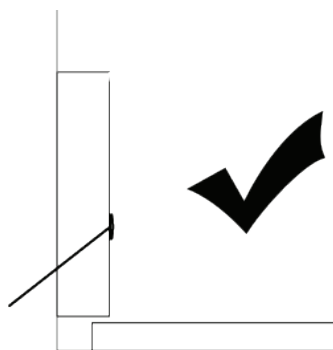
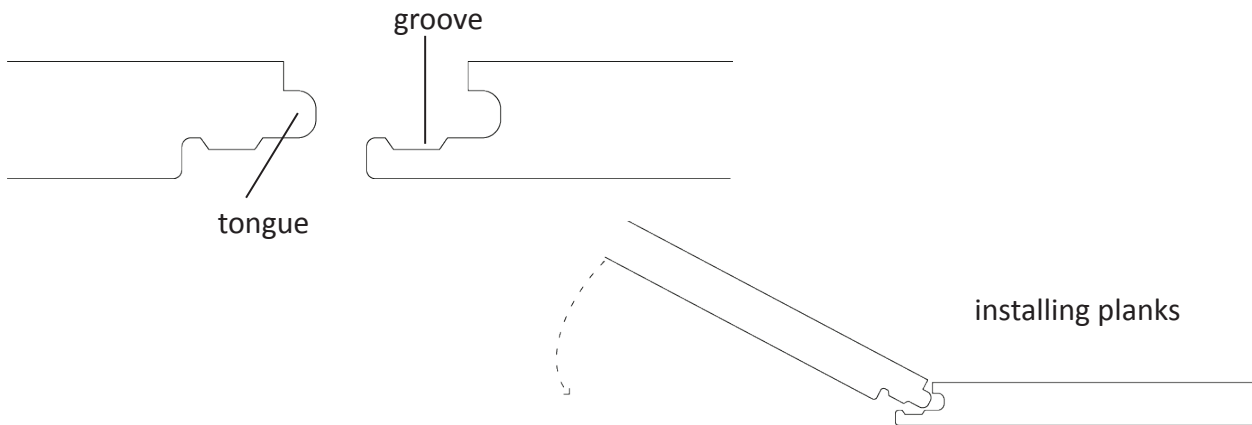
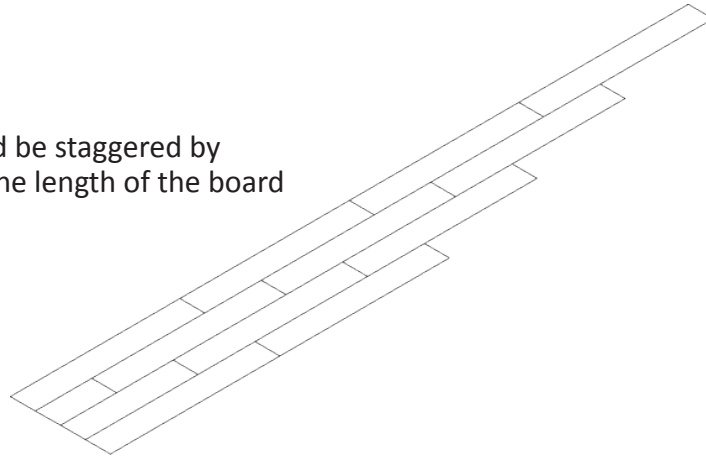

Correct way to nail baseboard trim—  
*through the wall, not the floor*

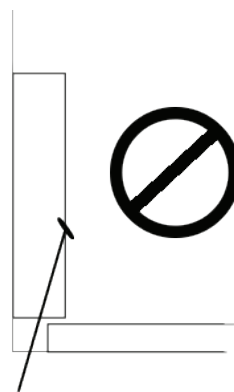

Incorrect way to nail baseboard trim—  
*through the floor*

## REPLACING LAMINATE FLOOR

If you run into a problem with a single piece of laminate in a floor that is fully assembled, there is a convenient method to remove and replace that single piece.

*If near a parallel wall:*

1. Remove the baseboard with a pry bar.
2. Begin removing pieces of the flooring, numbering it on the back to make sure that it gets put back in order.
3. Once you reach the problem piece, remove, replace, and then put the floor back together.

*If the previous method will not work:*

1. Mark 1.5" in from all sides on the piece to be replaced. Drill 3/16" holes in the corners.
2. Set saw depth to thickness of the plank, and cut along the relief lines. Pull out the center piece, and gently remove the rest of the plank.
3. Prepare the new piece by removing the bottom of the grooves. Remove the tongues with a utility knife. Apply wood glue to the top of the existing tongues and the underside of the grooves on the new piece.
4. Place the piece into position and wipe up all excess glue. Lay heavy weights across the piece, and allow to set for 24 hours.

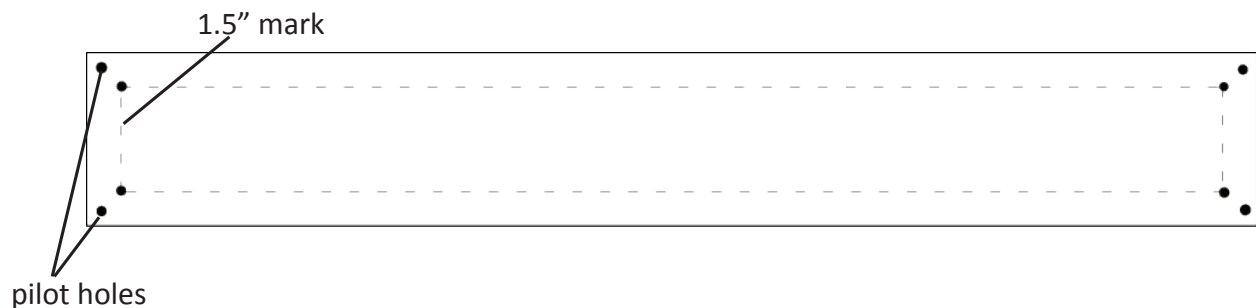

## VINYL PLANKS

Vinyl planks look like laminate, but have the flexibility of vinyl. They are a free floating system that simply peel and stick together. You only need to allow for minimal expansion, and the entire floor can be done rather quickly. They are a great product, especially if you want to get the floor done quickly. They are more expensive than VCT or laminate, but are easier to install and maintain. One problem is the vinyl planks tend to separate when exposed to a lot of water.

***We do not use them in bathrooms.***

For installation, see directions on box.

# WALLS, WINDOWS & DOORS

## SAFETY

### LEAD PAINT

- Lead paint can be present on almost any home, and it is always best to assume that paint is lead based
- Avoid dry scraping paint as much as possible
- Never sand a painted surface, or use a heat gun to remove paint
- Always wear an appropriate mask when working with or removing any material with loose paint

### KICKERS

- Kickers should be put in place any time you are removing any sort of support from a wall, or underneath a wall. Movement that could result from a lack of sufficient temporary support can create dangerous situations

### DRYWALL

- Always wear a dust mask when sanding drywall mud
- When cutting drywall with utility blades, make sure the work area is being kept safe—i.e., materials are well-secured when cutting, blades are closed or covered when not in use, and the area is well-lit and free of excessive dust and clutter
- Hardhats should be worn anytime tools are being used overhead, working on ceilings, or working on walls from a ladder

| MAXIMUM SPAN FOR DOUBLE HEADERS |                      |                 |                   |
|---------------------------------|----------------------|-----------------|-------------------|
| DIMENSION OF LUMBER             | SUPPORTING ROOF ONLY | ONE STORY ABOVE | TWO STORIES ABOVE |
| 2X6                             | 4'                   | 2'              | N/A               |
| 2X8                             | 8'                   | 6'              | 4'                |
| 2X10                            | 10'                  | 8'              | 6'                |

## WALLS

Walls consist of 3 main parts:

1. Studs: the vertical member of the wall, used as supports. Pre-cut studs are normally 92 5/8" in height. Pre-cut studs, when combined with a double top plate and single bottom plate, make a wall just over 8' high.
2. Top Plate: rests on the top of the studs and is used to support the roof, or the second story of the home. The top plate is doubled to increase strength and tie the corners and interior walls together.
3. Bottom Plate: rests on the sub-floor. All of the studs rest on the bottom plate.

Walls are typically constructed with 2x4s, although sometimes you may run into different dimensions.

When using 2x4s, try to use R-15 insulation (R-13 is the minimum insulation to be used. R-11 is not used).

### *NEW WALL CONSTRUCTION*

Before building walls, you need to know if the wall is going to have a door or a window.

1. New walls are typically built lying flat on the ground, then tilted into place and connected to other walls with the second top plate. Clean and level the floor prior to constructing your walls.
2. Place studs 16" on center in the walls. Layout the wall framing so that the drywall will land on a stud. This means marking the top and bottom plate for the studs, and face nailing each stud through the top and bottom with (2) 12d nails on either end.
3. Frame out for windows, doors, and any bracing at this time. Do not try and wait until the wall is in place. Use 2x10s for all outside wall headers.
4. Where one wall intersects with another, a ladder is required to connect the two. See corners and interior walls.
5. **Place a generous bead of caulk down on the subfloor where each sill plate will rest immediately before raising walls.** Also run a bead of caulk vertically where the corners meet and around each window and door to air seal the wall. Stopping uncontrolled air movement from the inside to outside and visa-versa is one of the best methods to help enhance energy efficiency.
6. Raise the walls into place once framing is complete. Temporarily brace the walls until the roof is in place. Check that everything is plumb, level, and square, and nail the bottom of the wall into the floor with 12d nails between each stud. Hit the floor joists where possible.

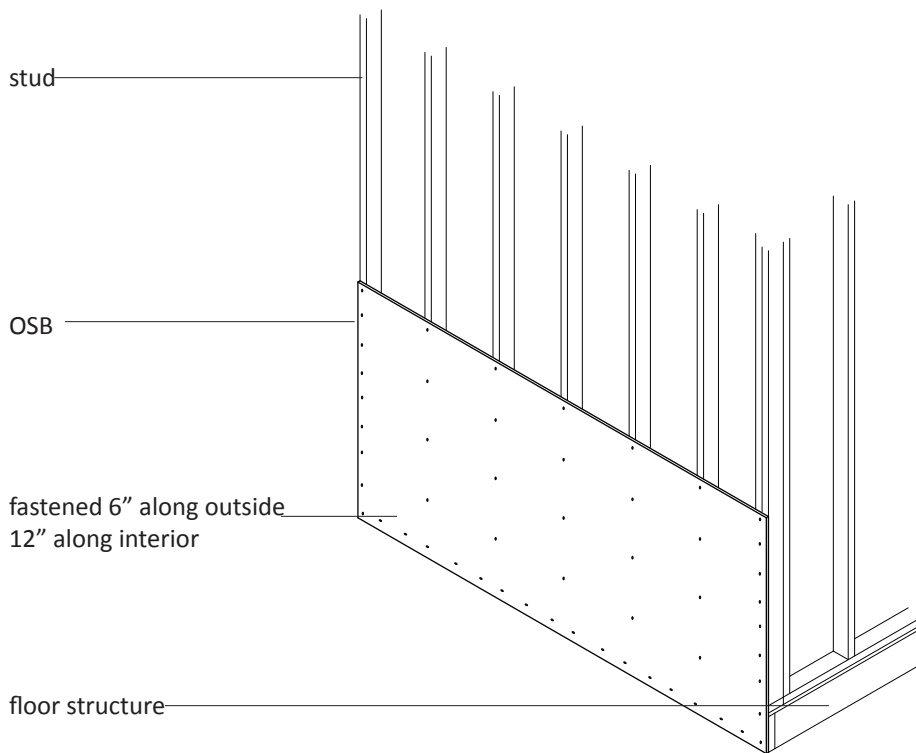
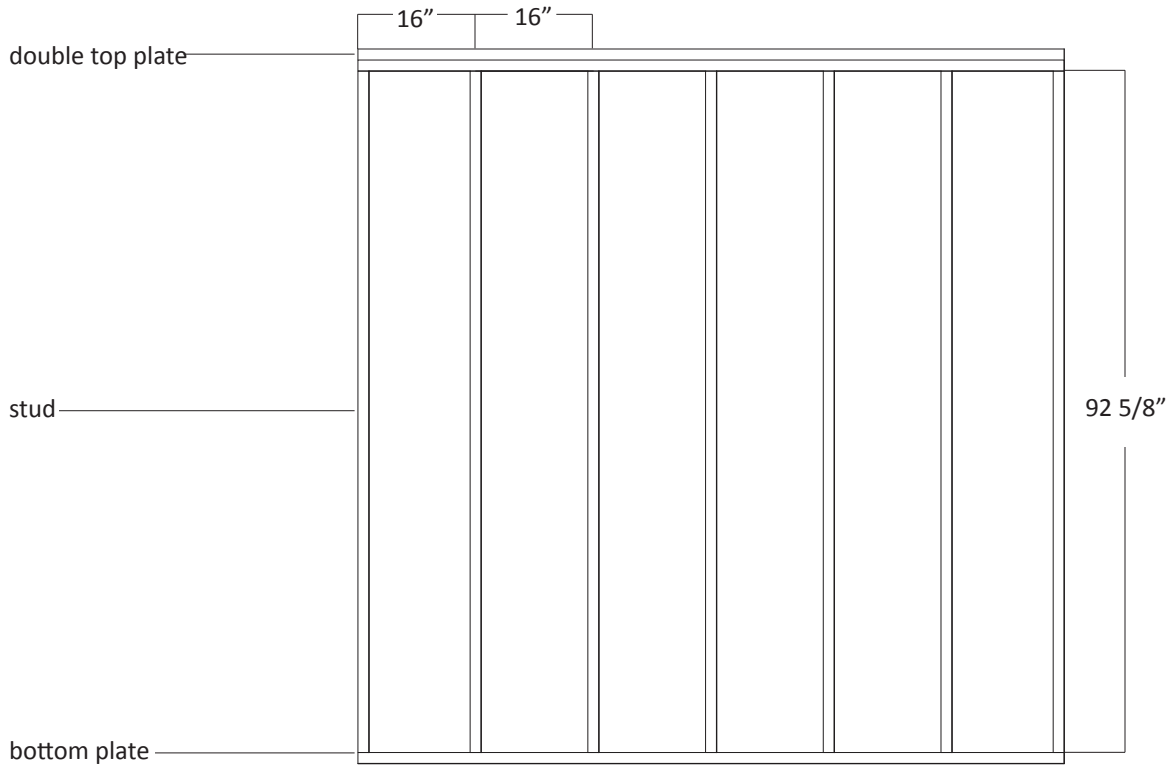

## *SHEATHING THE WALLS*

Sheathing provides lateral stability (side-to-side) and an exterior air seal for the wall system. Sheathing should be installed on the entire exterior of the home to provide nailing surfaces for siding and increase strength. Install horizontally.

1. Begin installing ½" OSB sheathing at the bottom of the wall, make sure that it comes down over the floor system and attaches into both the floor frame as well as the wall studs.
2. Fasten every 6" along the perimeter of the sheet, and every 12" through the interior. Use either 8d nails or 1.5" screws.
3. Stagger vertical seams, if any, at least 2'. Cover the entire surface of the wall; you may need to rip OSB into thinner strips to complete the top of the wall.
4. Apply a bead of caulk or tape at each seam and at the edge of the sheathing. Use a putty knife to work it into the seams.

## *CORNERS AND INTERIOR WALLS*

Tie walls together at corners and "T"s using the double top plate. The lower member of the double top plate ends at the last stud. The second top plate overlaps the connecting wall.

California corners: The walls are framed, and a 2x4 is added to the inside of the wall, forming a corner. The inserted 2x4 will act as a nailer for drywall, and allows for more insulation.

Triple corners: 3 studs are nailed side by side and placed in the wall at a corner in place of the California corner. A triple corner is stronger than a California corner, but does not allow as much insulation.

Ladder framing: used to attach interior walls to exterior walls. Ladders are typically 2x4s placed between two studs at 24" centers. Ladders act as fasteners for the drywall, as well as supporting the interior wall.

## *SCABBING STUDS (OF NO VALUE IF THE MOISTURE PROBLEM IS NOT ADDRESSED FIRST)*

If rot in a wall is localized, then you can simply scab the studs in the affected area. Work on one stud at a time, so as not to shift the load of the roof too much.

1. Remove insulation around the stud to be repaired. Measure for a replacement piece of stud to be inserted into the bad section.
2. Cut out the bad piece of the stud, removing it completely.
3. Install the new section of stud, and place scabs on either side of the new seam. Fasten with 12d nails.



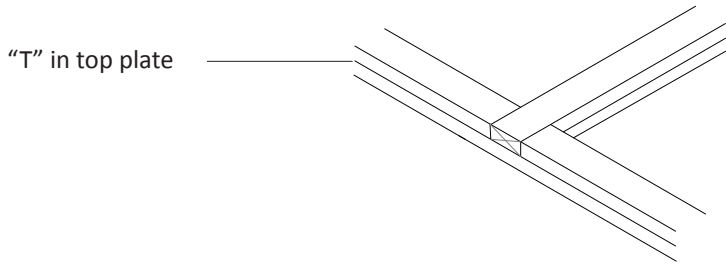

California corner

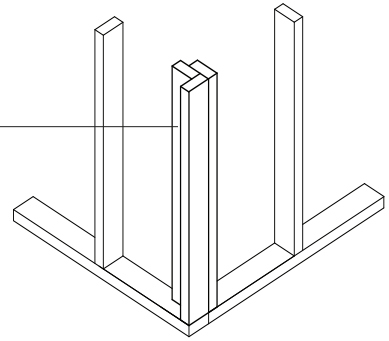

Triple corner

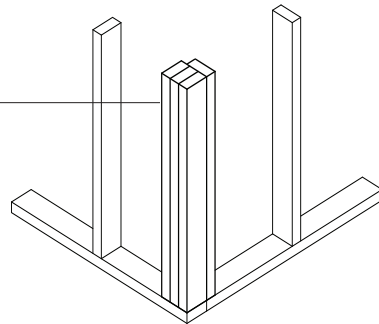

Ladder framing

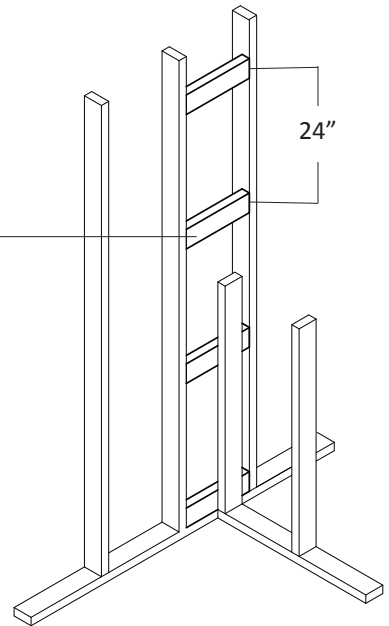

stud

scabs

location of rot

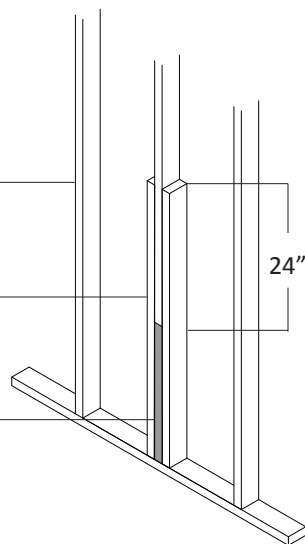

## *REPAIRING THE BOTTOM PLATE (ADDRESS THE MOISTURE PROBLEM)*

If the bottom plate is rotten, most likely the studs will be affected as well.

1. Install kickers on the outside of the wall. See Floors for more details. A temporary wall can be built inside the house instead of using exterior kickers. Mount a flat 2x4 against the ceiling, and another directly beneath it on the floor. Wedge 2x4s acting as studs between the top and bottom plates. This should be done with enough room to still have access to the rotten bottom plate.
2. Remove the bottom plate in 8' sections to prevent too much load shift.
3. Cut the studs loose from the bottom plate with a reciprocating or hand saw. Remove the bottom plate, as well as any rotten stud bottoms.
4. Replace the bottom plate.
5. Scab any studs that need repair, and reattach to the bottom plate. Continue this down the length of rotten bottom plate, and when finished, remove kickers.

## *JACKING WALLS*

Discuss with ASP staff before any jacking occurs. Jacking should only happen when completely necessary, and under experienced supervision.

***Use only a hydraulic jack, never a car jack.***

1. Screw 2x6 to solid wall framing at least 6" above rotten bottom plate.
2. Temporarily build piers out of CMU (block) to support the jack. Alternate the direction of each level CMU, and make sure that the holes face upwards. Place boards across the top of the pier to evenly distribute the weight.
3. Once the temporary piers are in place, set the jack on top and raise so that it touching the 2x6. Slowly jack the 2x6, never raising the wall more than necessary.

## **WINDOW FRAMING**

Window framing has 5 main components:

- Header: a heavy beam that extends across the top of the rough opening to prevent the weight of the wall or roof from resting on the window frame, carrying weight out to the jack studs.
- Jack Stud: a vertical framing member running from the bottom plate to the header, forming the vertical sides of the rough opening.
- King Stud: a vertical framing member running from the bottom plate to the top plate, alongside the jack stud.
- Cripples: short studs placed between the header and a top plate or between a sill and bottom plate.
- Sill: horizontal member that forms the bottom of rough opening.

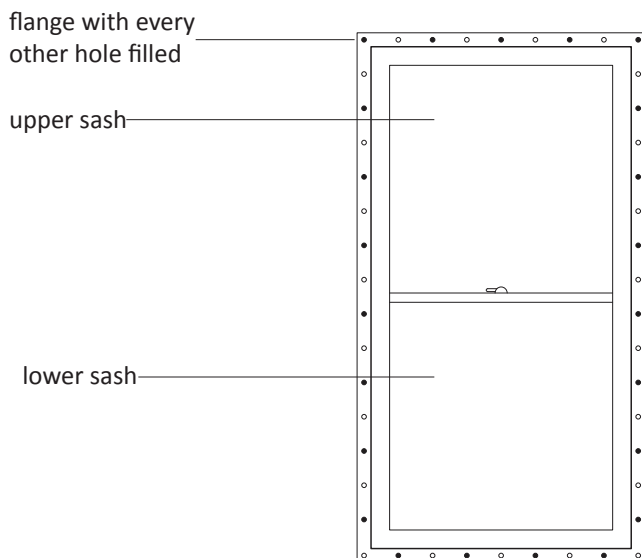
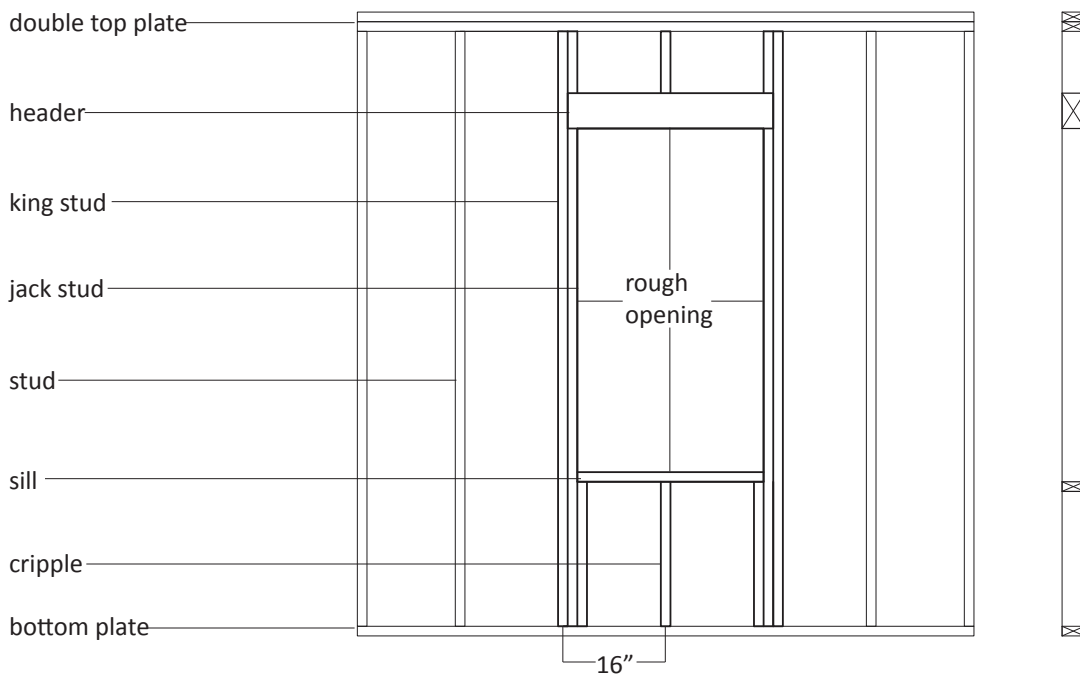
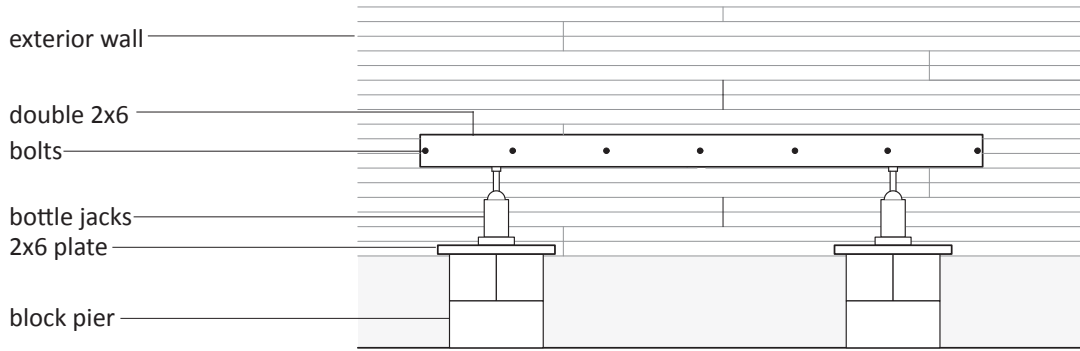

## WINDOW OPENINGS

Rough opening: the size of the hole to be framed in the wall.

Nominal size: the actual size of the window. Check with the staff before framing for a window.

The rough opening should be 1" taller and wider than the actual window size. When ordering a new window, order according to the rough opening.

The layout of a window opening is dependent upon the size of the window to be installed.

At least one window or door in each bedroom is required to be egress. Staff should check with local inspectors for code requirements. ASP will be providing egress windows at 36" wide x 62" high (single hung), or 48" wide x 48" high (slider). Home Depot carries these sizes in stock.

## FRAMING A WINDOW

1. Determine rough opening size.
2. Build a header out of two pieces of lumber with a spacer in the middle, like a small girder. The spacer should be ½" OSB, or ½" blue foam. Keep header nearby. All headers on exterior walls should be 2x10.
3. Install the king studs first, using the length of the header to determine spacing. Anchor with 12d nails.
4. Attach header to king studs with 12d nails, nailing from both sides. Use the header chart for minimum lumber dimensions. *Always use 2x10 for outside walls.*
5. Install jack studs underneath header and inside of king studs. Secure jack studs to the king studs, checking that they are square and plumb.
6. Double check measurements for rough opening and cut cripples to fit underneath the sill. Cripples should still be 16" on center for 2x4 walls. Install cripples above the header, as well as the 2 that support the ends of the sill. Install the sill, a flat 2x4. If needed, install remaining cripples.

## INSTALLING WINDOWS WITH FLANGES

Most new windows will come with flanges. Try to purchase flanged windows when possible as they are much easier to install.

1. Place the window in the opening to test fit.
2. Remove, and put a thick bead of caulk around the flange. This will form a seal between the window and the sheathing.
3. Re-set the window, and check for square and plumb (very important in a functioning window). Nail the flange into place with roofing nails in every other hole. Reinstall the sash prior to nailing the window into place.
4. Use housewrap tape to seal the sides and top of the window, not the bottom. The top tape should overlap the sides. Do not cover the bottom weep holes.
5. Use spray foam (intended for windows and doors) to fill the space between the window and the framing.

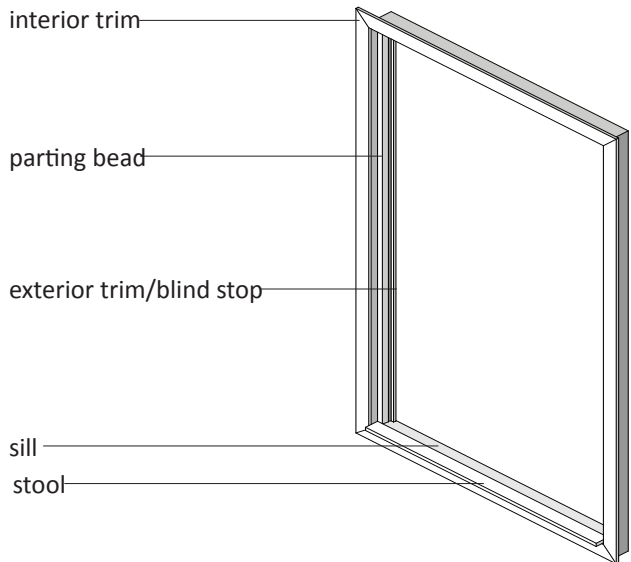
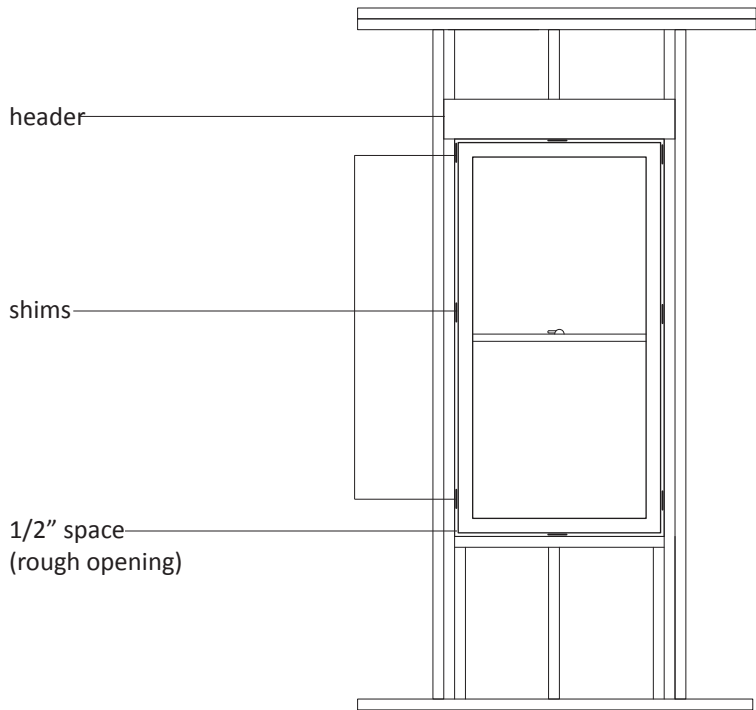
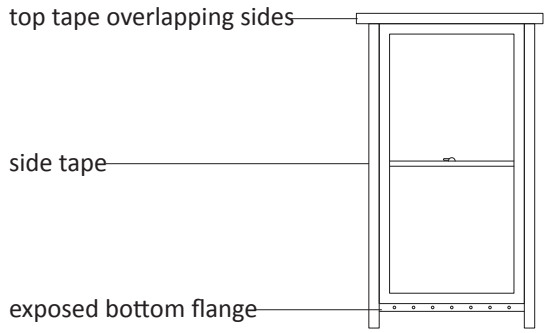

## INSTALLING WINDOWS WITHOUT FLANGES

Windows without flanges will usually have an exterior trim (brick molding).

1. Place window in opening, and shim the sides and bottom of the window. There should be at least 3 shims along the bottom and up each side. **No shims at the top.**
2. Drive 12d nails or 3" screws through the molding into the framing, with at least 3 per side. Trim all shims flush.
3. Use spray foam (intended for windows and doors) to fill the space between the window and the framing.

## INSTALLING REPLACEMENT WINDOWS

Vinyl replacement windows are a great way to save a family in heating and cooling costs, as well as make them feel proud of their home.

1. Measure for the replacement window and **order ahead of time.**

*To measure for a replacement vinyl window*

- HEIGHT is measured from the top of the window sill to the bottom of the head of the window
  - WIDTH is measured from the left side of the window to the right, from seam of molding to seam of molding
  - *Subtract ½" from the height, and a ½" from the width when ordering*
2. Install the window from the outside of the home. Pop off the outside trim, and remove the sashes of the window. If there are tracks, remove them, as well as the parting bead. Leave the wood framing intact.
  3. Vacuum the opening with a shop-vac using a HEPA filter.
  4. Place new window in the hole for a test fit. Remove.
  5. Caulk inside stop with a generous bead of caulk, as well as the sill and header.
  6. If needed, place the head expander onto the window and apply a generous bead of caulk to the top.
  7. Fit window into place, flush against the inside stops.
  8. Check for plumb and level. Insert shims, making sure to place them behind screw holes so that screws won't warp the window.
  9. Secure the window through the pre-drilled screw holes (these may have covers on them; if so, remove, fasten, and replace).
  10. Raise the head expander so it is tight against the header.
  11. Insulate any and all gaps, using either low expansion foam or fiberglass insulation.
  12. Trim the outside of the window.

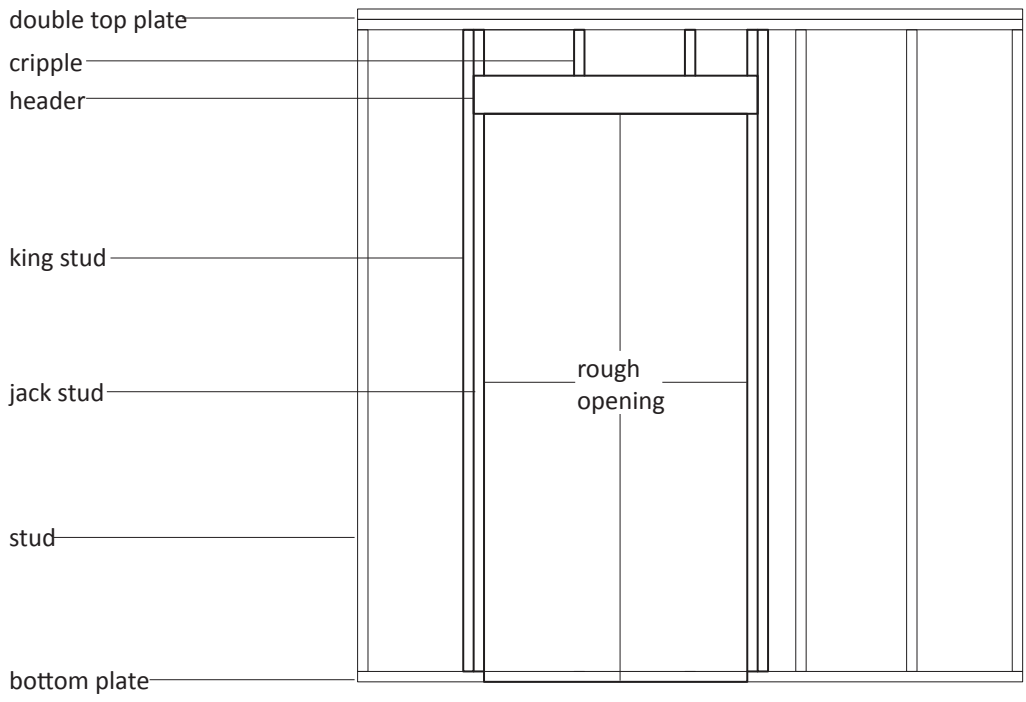
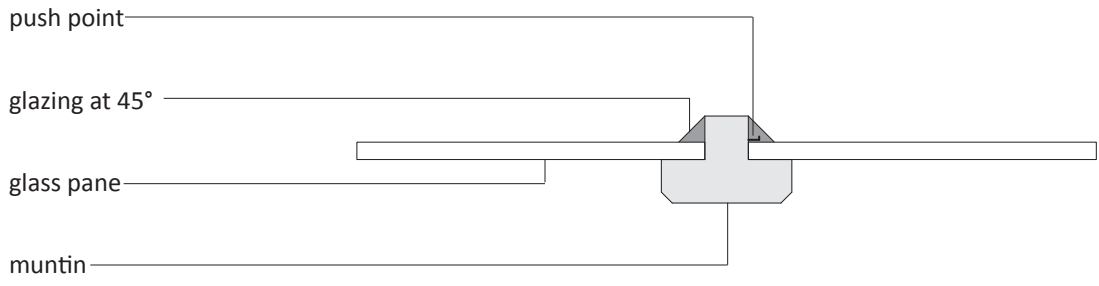

## GLAZING

Glazing is putty that is used to hold window panes in place.

1. Completely remove all existing glazing.
2. Prime the wood to prevent moisture from being drawn out of the glazing.
3. Roll a thin snake of glazing, and place around the edge of the glass. If any dimension of the pane is greater than 24", use push points every 12". Push points should be pressed firmly into the muntin, firmly against the glass.
4. If needed, work a small amount of linseed oil into the glazing to make it more pliable. Use a putty or glazing knife to press the glazing firmly into the muntin, forming a 45 ° angle. A small amount of dish detergent on the knife will help to smooth the glazing.
5. Paint the glazing to prevent cracking and drying.

## DOOR FRAMING

Door frames have 4 major components, similar to windows: header, jack stud, king stud, and cripples.

There are 2 types of doors:

- Exterior doors: solid doors that provide more insulation and fire protection than interior doors. Typically they are 36" wide and 1 3/4" thick, but can actually be found in a variety of sizes. New exterior doors should be made of metal, and usually need to be painted.
- Interior doors: commonly hollow cored without any insulation. They have rails along the edges with structural honeycomb inside the door. They come in a wide range of sizes, typically 1 3/8" thick.

Doors have 2 measurements—the rough opening and nominal size—just like with a window.

1. Determine rough opening size (2" wider and 2" taller than actual door).
2. Build a header out of two pieces of lumber with a spacer in the middle, like a small girder. The spacer should be 1/2" OSB, or 1/2" blue foam. Fasten with 12d nails. Use the header chart for minimum lumber dimensions. **All exterior walls require a 2x10 header.** Non-load bearing walls require only a flat 2x4 header.
3. Install the king studs first, using the length of the header to determine spacing. Anchor with 12d nails.
4. Secure jack studs to the king studs, checking that they are square and plumb. Set header above jack studs, and fasten to the king studs as well.
5. Double check measurements for rough opening, and cut cripples to fit above the header. Cripples should still be 16" on center for 2x4 walls. Install cripples.
6. Once a new wall is raised, the bottom plate will be cut out of the door frame.



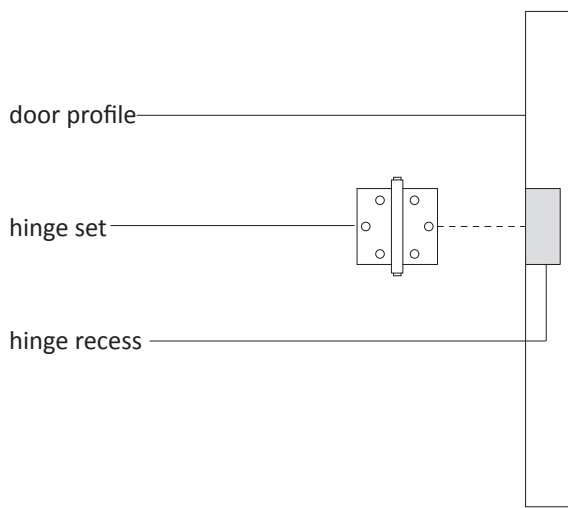
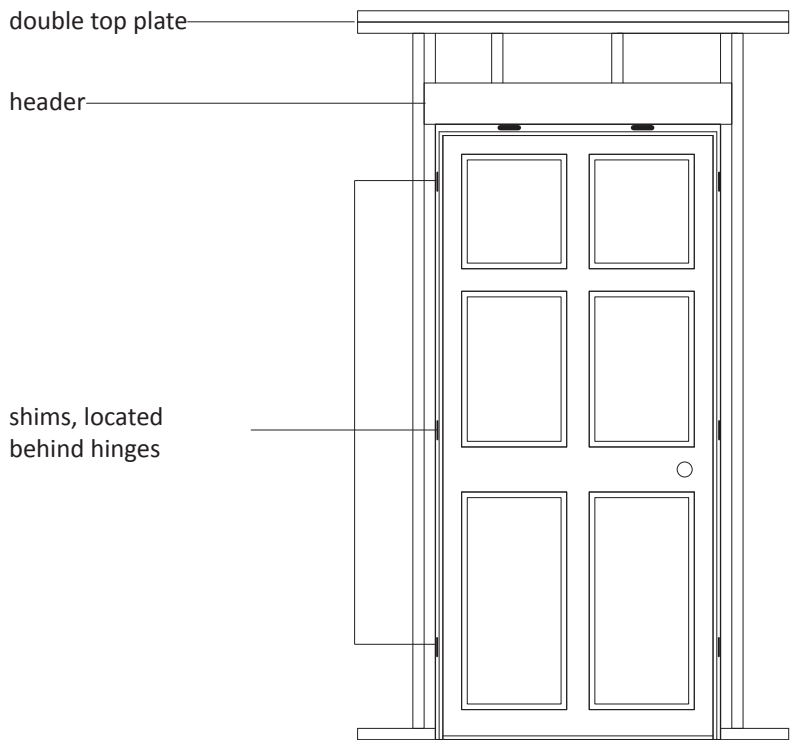

### *DETERMINING DOOR SWING*

1. Stand with your back to where the hinges will be.
2. Swing your arm as if it were the door. If you swing your left arm, then you need a left hand door. If you swing your right arm, then you need a right hand door.

### *INSTALLING PREHUNG DOORS*

Always purchase pre-hung doors. Pre-hung doors are already attached to the jamb, and may even have trim attached. Pre-hung doors come apart rather easily; the door jamb typically comes apart into 2 pieces and is only tacked together with small braces.

#### ***Always caulk under the sill of exterior doors.***

1. To install the door, take off the braces and place the door in the opening.
2. Shim the sides of the door, checking for level and plumb. Secure the door with finish nails, nailing through the jamb and shims. On interior doors, the door stop can be removed and the nails or screws go in that spot. The stop is then reinstalled, hiding the fasteners.
3. When shimming exterior doors, shims must be placed directly behind the hinges of the door. Instead of nailing the door, run a 4" screw through one hole in each of the hinges and through the shims.
4. Make sure that interior doors have a 3/4" clearance under the door. Exterior doors should fit snugly against the threshold. The threshold can be adjusted slightly if need be, using the screws included.
5. Use spray foam (intended for windows and doors) to fill the space between the door jamb and the framing.

### *HINGES*

Doors require 3 hinges. Center hinges should be halfway up the door. The top hinge should go 7" down from the top of the door, and the bottom hinge 11" up from the bottom.

1. Lay each hinge on the door and trace the outline of the hinge. Use a chisel to mortise the recess for the hinges.
2. Install the hinges. Always insert the hinge pin from the top of the hinge.
3. The door should have a 1/8" reveal across the top.

### *LOCKSETS*

Pre-hung doors have the hole for locksets already cut out. To install a lockset manually, follow manufacturers' directions.

Make sure to correspond the purchased lockset with the intended use (interior vs. exterior).

# ROOF FRAMING

## ROOF SAFETY

### LADDERS

- Secure the ladder where it meets the roof with rope or wire to keep it from moving side to side
- Extend the ladder 3' above the roof line
- Always set up the ladder on even ground
- Always have somebody holding the ladder when in use
- 4' to 1' ratio—the ladder should be 1' out from the wall for every 4' of height

### HARDHATS

- Anybody working on the ground under a roofing project should be wearing a hardhat

### ROOF JACKS

- Roof jacks are **REQUIRED** on all roofing jobs
- Roof jacks should be installed at the base of the roof, secured by nails when attached to decking, and screws when attached to furring strips through the tin
- Three roof jacks per board is ideal
- One nail can go into the hole that sticks up into the edge of the board to keep it from sliding

### DANGEROUS CONDITIONS

- Wet roofs are very dangerous, do not go up a wet roof
- Sunny days create dangerous heat and sun glare on metal roofs, encourage more breaks on hot sunny days
- Dewy mornings sometimes leave a small amount of water on the roof—do not go onto a wet roof, or out to work on a roof early in the morning
- Sawdust can become very slippery on a roof, **NEVER** make cuts on the roof, cut material on the ground, and pass it up to the roof

### FALLING OFF/FALLING THROUGH

- Particularly dangerous areas of the roof should be marked
- Edges can be marked with small strips of wood with caution tape tied to them
- Weak areas that a person may go through the roof can be painted with bright colored paint
- Ceiling joists should not be a walking surface, slide additional boards in to stand on, and tack them in place if you need to stand in the attic

### BATS

- If bats are present, or evidence of bats is present, do **NOT** work on the roof

### POWER TOOLS

- A large variety of power tools will be used at various points while working on roofs
- Create a good, safe cutting station on the ground, in a place where materials can be most easily transported up and down the roof

## ROOF & CEILING FRAMING

Roofs protect homes from water intrusion. A roof frame provides the structure for the roofing system and rests upon the walls, distributing its weight through walls, floors, and foundation to the ground.

The 2 primary methods of roof frame construction are rafters and trusses. While rafters are virtually always “stick framed” on site, trusses are purchased pre-built from a supplier. Trusses utilize smaller sizes of lumber to accomplish the same results as rafters.

### CEILING JOISTS

Ceiling joists are a series of parallel framing members that add support to the walls. Ceiling joists are supported by load bearing walls. Prior to installing ceiling joists, make sure that all walls are braced and plumb.

1. Determine size of lumber for ceiling joists.
2. The ends of the joists may need to be angled so that they will not interfere with the pitch of the rafters. Cut the joists to length, and angle cut the ends.
3. Install the ceiling joists on 16” or 24” centers. The joists that are parallel to the outside walls at the end of the room will need to be set at the inside edge of the wall.
4. Once the ceiling joists are in place, toe-nail them into the top plate of the wall using 12d nails.
5. Ceiling joists can only span so far; if you cannot span the entire distance, an interior wall may be necessary. Over the top of the wall, you can break the span of the joist. Do not overlap any more than 24”, and toe nail into the top plate.
6. When ceiling joists run parallel to an interior wall add nailers, or an extra joist, to catch the drywall.

### RAFTERS

“Stick frame” roof systems are built using rafters and a ridge beam. The ridge beam runs down the center of the roof, and the rafters lean against the ridge beam.

- Rafter: a framing member that extends from a ridge (or hip) to the top plate of the wall to support the decking and roof cover.
- Ridge beam: a horizontal framing member at the top of the roof where the rafters meet. The ridge beam always runs perpendicular to the ceiling joists.
- Eave: the edge created by the overhang of the rafters.
- Gable: the triangular ends of the roof
- Rake: the edge created by the rafters on the gable end

| CEILING JOIST SPAN CHART |                              |   |                  |
|--------------------------|------------------------------|---|------------------|
| NOMINAL JOIST SIZE       | SPACING IN INCHES ON CENTER* | NORTHERN SPRUCE OR SOUTHERN YELLOW PINE |                  |
|                          |                              | LIMITED ATTIC STORAGE                   | NO ATTIC STORAGE |
| 2X4                      | 16"                          | 8'7"                                    | 11'0"            |
| 2X4                      | 24"                          | 7'3"                                    | 9'5"             |
| 2X6                      | 16"                          | 12'10"                                  | 15'10"           |
| 2X6                      | 24"                          | 11'0"                                   | 14'9"            |
| 2X8                      | 16"                          | 16'3"                                   | 19'7"            |
| 2X8                      | 24"                          | 14'0"                                   | 18'9"            |
| 2X10                     | 16"                          | 19'10"                                  | 24'0"            |
| 2X10                     | 24"                          | 16'4"                                   | 22'11"           |

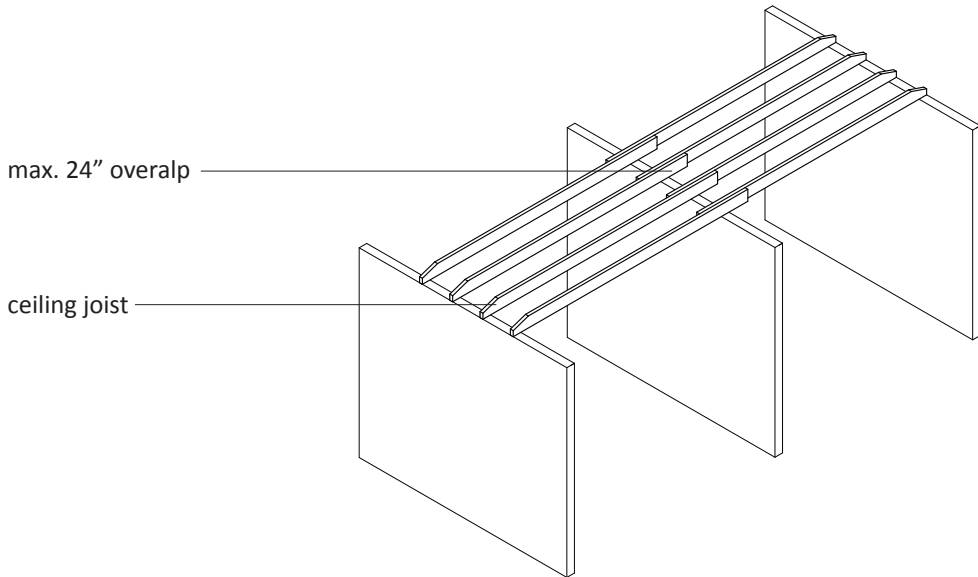
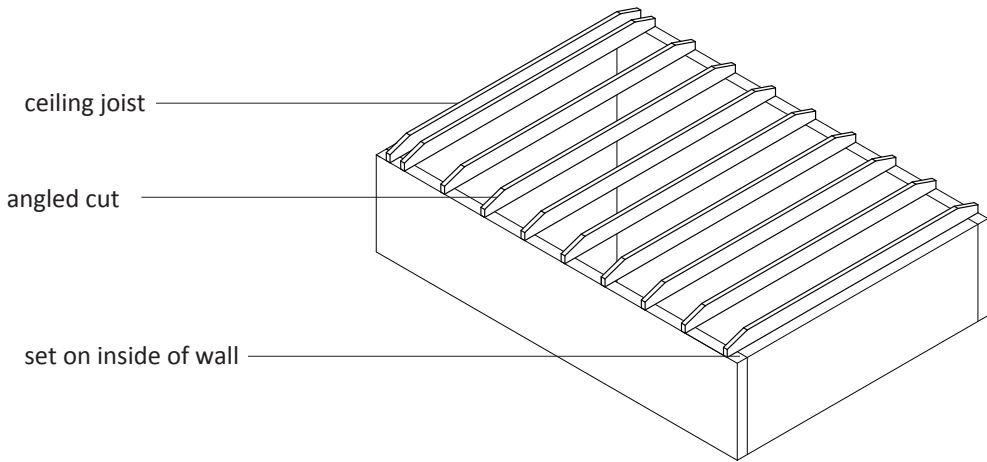

## RAFTER CONSTRUCTION

Pitch: the slope of the roof, determined by placing rise over run, or vertical height over horizontal distance. The run is measured in increments of 12. If a roof has a rise of 5" for every 12" of run, the roof has a 5:12 pitch.

1. To determine the run of the roof, measure the entire width of the area to be roofed, and divide in half. The pitch on a new roof should be between 3:12 and 4:12.
2. Determine lumber to be used. Ridge beams need to be at least 1 dimensional size larger than the rafters, e.g. if using 2x6 rafters, the ridge beam needs to be at least a 2x8.
3. Determine rafter length using the Pythagorean Theorem,  $A^2+B^2=C^2$ . A= distance from top of wall to top of ridge beam; B= half of width of the entire roof minus  $\frac{3}{4}$ ". C= rafter length, plus 6-12" for overhang.
4. Install the ridge beam. The ridge beam will need to be supported during rafter installation; brace the ridge beam every 6' with a 2x4 Y-brace. If the ridge beam is longer than available lumber, splice 2 pieces, adding scabs to hold them together.
5. If the roof has fly rafters, the ridge beam will need to extend 12" past the exterior walls.

## CUTTING RAFTERS

Once the ridge beam is in place, rafters can be cut and installed.

Plumb cut: a cut made perpendicular to the ground.

Bird's mouth: a notch that allows the rafter to sit on the top plate; comprised of a plumb cut and a seat cut. Only used when replacing existing rafters.

1. Make a plumb cut on the rafter. Use a speed square to mark these cuts. There will be a plumb cut at either end of the rafter, and in repairs where the rafter meets the top plate of the wall (bird's mouth).
  - Crown the lumber.
  - Take the speed square and place the pivot point at the corner of the rafter lumber.
  - Pivot the square so that the length of the lumber is matched to the pitch of your roof, marked on the square.
  - Mark the angle on the lumber. Extend this mark to the edge of the lumber.
  - Cut the lumber. You have made the face that will connect to the ridge beam. The rafter tail can be cut once all rafters have been installed.
2. Cut the bird's mouth. Bird's mouths are only required when replacing some rafters. In new construction or if you are replacing all of the rafters on one side of the roof, simply set the rafter on top of the wall and use a hurricane strap.
  - To determine the placement of this plumb cut, use the value C found with the Pythagorean Theorem ( $A^2 + B^2 = C^2$ ).
  - Mark the distance C. This will be where you make the plumb cut of the bird's mouth. Use the speed square to mark a line for the cut.
  - At a right angle to the plumb cut, measure 3.5" to the edge of the rafter and mark a line. This will be the seat cut.
  - Cut the bird's mouth with a circular or hand saw. Do not go past the marks, as this will weaken the lumber.
3. Cut a single rafter, and test fit it. If it fits, use it as a template for the rest of the rafters, double checking as you move down the house since older homes can have wavy walls. Allow plenty of time for this process, as it can be tedious.

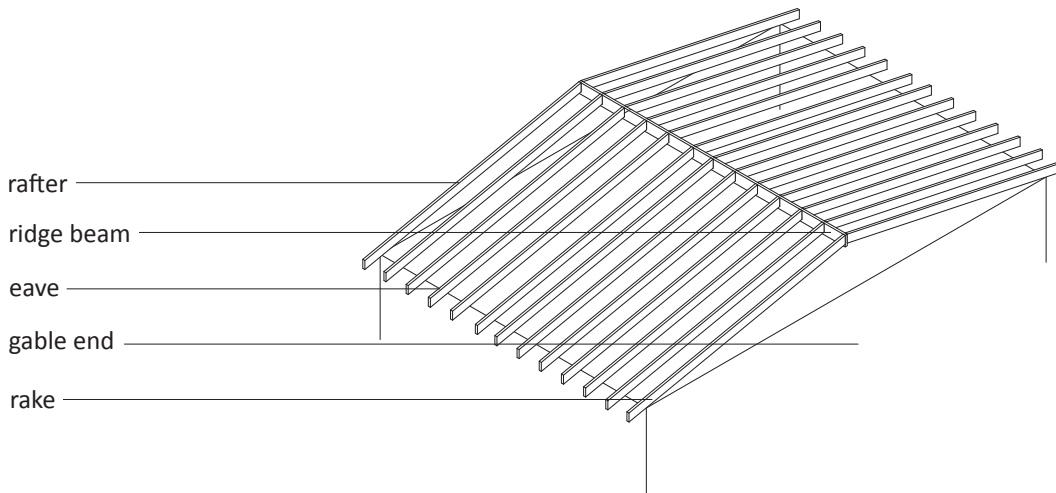

| RAFTER SPAN DATA       |                             |                                   |
|------------------------|-----------------------------|-----------------------------------|
| NOMINAL SIZE IN INCHES | SPACING IN INCHES ON CENTER | MAXIMUM SPAN<br>SPRUCE: PINE: FIR |
| 2X6                    | 16"                         | 13'5"                             |
| 2X6                    | 24"                         | 11'9"                             |
| 2X8                    | 16"                         | 17'9"                             |
| 2X8                    | 24"                         | 14'10"                            |
| 2X10                   | 16"                         | 22'3"                             |
| 2X10                   | 24"                         | 18'2"                             |

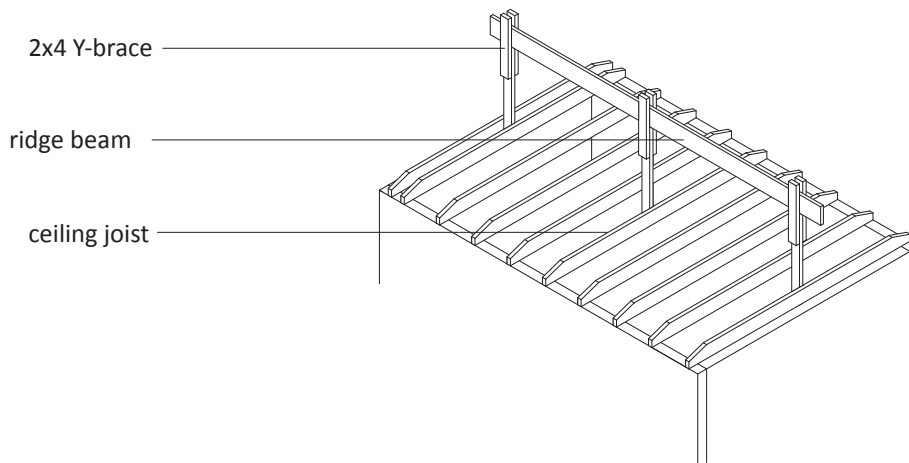
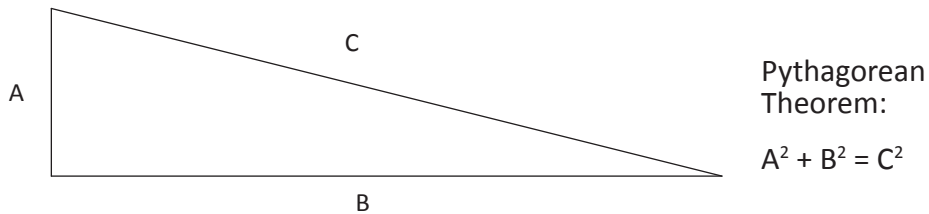

### *INSTALLING THE RAFTERS*

1. Mark the top of the wall and the ridge beam for 16" or 24" centers. The spacing is usually 24"
2. Begin installing the rafters on one gable end. Attach to ridge beam with 12d nails, and to the top of the wall with hurricane straps, nailed in securely.
3. Continue installing down the roof, double checking measurements and spacing as you go.

### *BARGE/FLY RAFTERS*

Barge/Fly rafters: rafters that hang outside of the exterior wall on the gable end of the house. These are used to help protect the gable ends of a house. They should be used only when matching older construction, and are placed 12" out from the exterior wall.

Lookouts: boards that support the fly rafters. They are usually 2x4s that are notched into the last 2 rafters and face nailed into the fly rafter.

### **DO NOT CUT PRE-ENGINEERED TRUSSES. EVER.**

1. Attach the lookouts to the rafters, and face nail the fly rafter on with 12d nails. This should be done with extreme care, as you are working high in the air on the edge of the roof.
2. Attach the fly rafter to the ridge beam and to the lookouts.
3. Fly rafters are not required on new construction houses.

### *FRAMING CHIMNEYS*

Chimneys require special attention in all steps of roofing. Make sure to have a solid plan before construction begins.

Trimmer rafters: rafters that sit on either side of the chimney.

1. Place rafters 1" away from the chimney on either side. These rafters need to be doubled up to provide extra support.
2. Place a double header between the trimmer rafters above and below the chimney. Make them out of the same size lumber being used for the rafters, and fasten with 12d nails.
3. Install a cripple from the header down over the wall. Attach in the same manner as you would a rafter, except that the top does not require a plumb cut.

### **TRUSSES**

Trusses are a more simple way to construct a new roof, or completely replace an existing one. They are essentially large triangles (typically) that are built on the ground and then raised into place to form the structure of the roof. They can be used on stick built homes, as well as over mobile homes. They should be pitched at 3:12.

Truss: a framing structure comprised of triangles. They are made of straight members and gusset plates; the trusses are then connected to one another with purlins.

Legs: the straight members that make up the truss

Gusset: a plate used to connect framing members to one another

Purlin: a horizontal structural member that supports loads from the roof deck



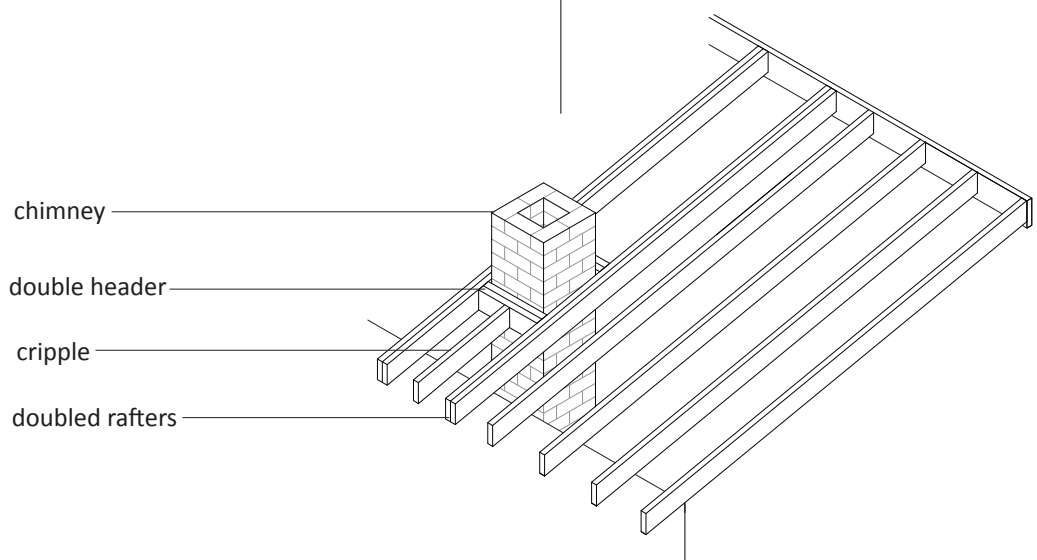
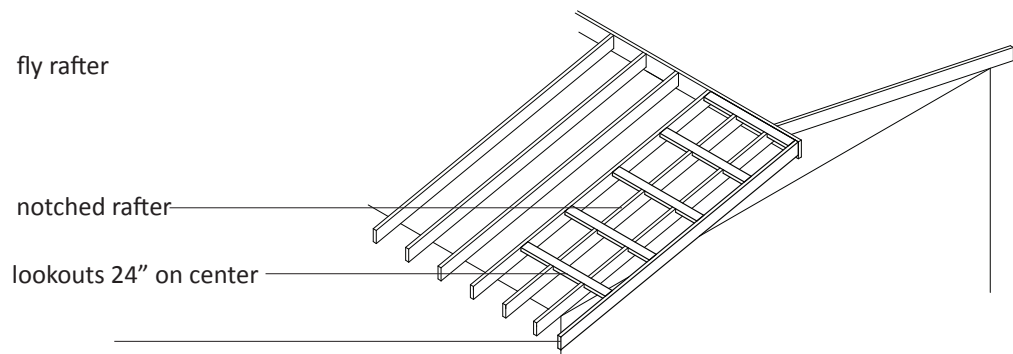
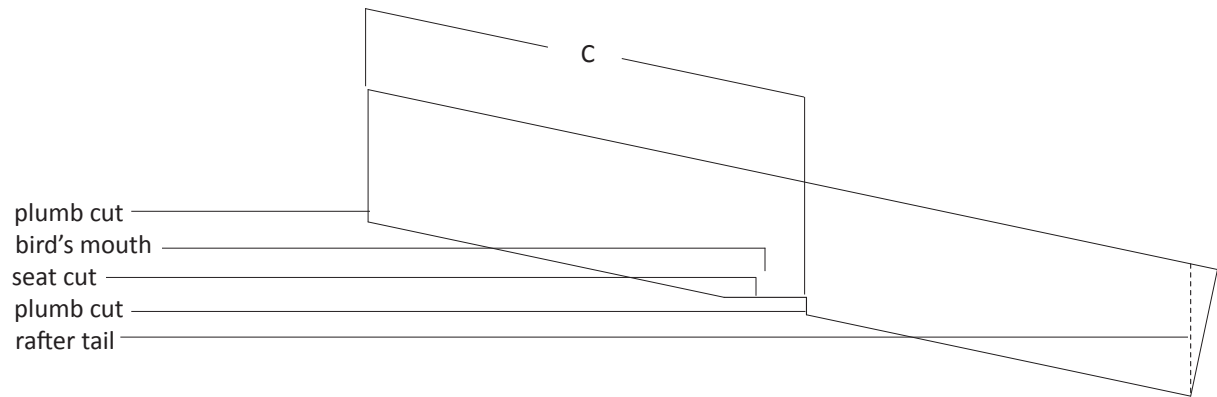
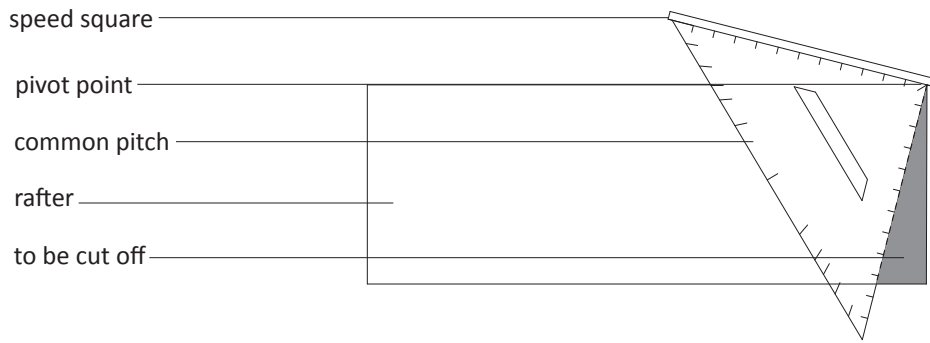

## *CONSTRUCTING TRUSSES*

1. Determine lumber size for construction. If the roof is 14' or less across, then 2x4's can be used as the legs; if greater than 14', use 2x6s.
2. Determine number of trusses required. They should be placed 4' on center along the length of the roof.
3. Create a template for ease of assembly. This can be done on a sheet of OSB. Cut plumb cuts on one end of (2) legs, and mark the center of the OSB. Lay the legs as they will be fastened together, and trace with a marker. Fasten 2x4 scraps along their edge, and nail or screw into the OSB. Now you can quickly find the correct pitch for all of your trusses.
4. Cut a sheet of OSB in thirds lengthways; this will be your first gusset plate. Trace the angles of your legs onto the OSB, and cut the resulting shape out. Use this as a template to create the rest of your gussets.
5. Glue the OSB gusset to the legs that are laid out on the template; make sure it is flush with the tops of the legs. Fasten with 8d nails or screws through the gusset into the legs. Remove from template and glue and fasten another gusset to the other side of the legs. This is the completed truss.

## *INSTALLING TRUSSES*

1. When installing trusses over a mobile home, you may need to build a pony wall, or reinforce the top plate of the wall. A pony wall will raise the roof system over any raised parts of the existing roof.
2. Mark the tops of the walls 4' on center, shortening the first and last spacing by  $\frac{3}{4}$ " to address length of roofing materials.
3. Mark the truss legs for purlins, which will be placed on 24" centers. Start at the top, and work your way out down, leaving off the last one or two to allow for plumb cut ends.
4. Raise the first and second trusses into place, and fasten 2x4 purlins across their tops. Fasten with 3" screws or 12d nails. The purlins will need to be staggered, so only fasten every other one.
5. Begin raising other trusses into place, moving down the roof, and checking for plumb and 4' centers. Fasten into place with purlins. When purlins ends must meet on a truss, split the width of the leg.
6. Fasten the trusses to the walls with hurricane straps, filling at least 3 holes with 12d nails. Make sure that you nail through the top plate of the wall, not just the siding.
7. Between each truss, place 2x4 blocking right on top of the wall. This will help keep insulation in place.
8. Trim the legs (rafter tails) with plumb cuts.

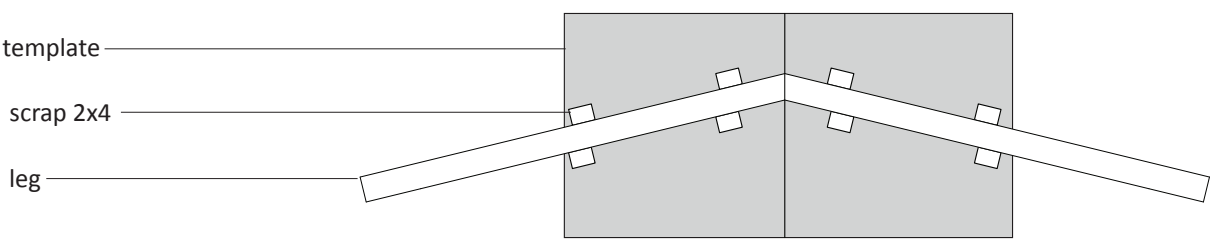
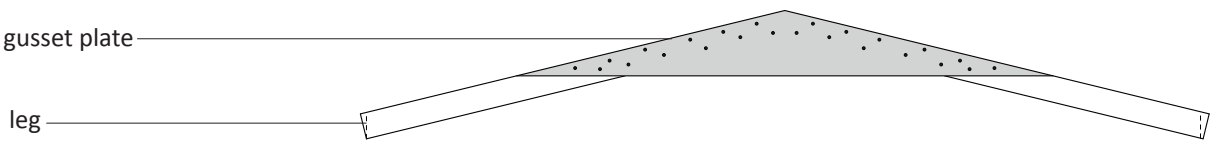
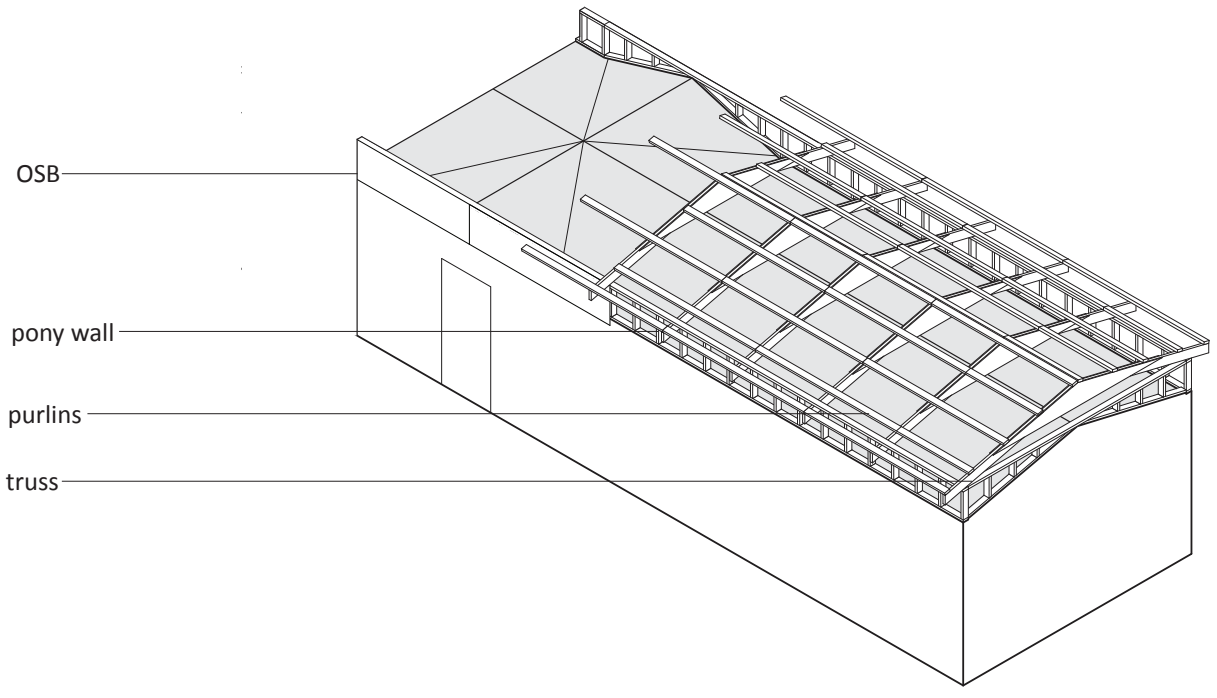

## *RAFTER TAILS*

Rafter tail: the end of the rafter that creates an overhang along the bottom of the roof. This area becomes the eave.

1. Measure out horizontally from the wall 12" to the rafter and make a mark. Draw a plumb line from that point up the side of the rafter. Do this on the first and last rafter.
2. Take a chalk line and snap a line along the tops of all the rafters, connecting the plumb lines of the outside rafters. This will create a clean and straight edge along the entire roof. Mark plumb lines from the chalk line on each rafter.
3. Use a handsaw to cut the rafter tails along the plumb lines. Circular saws are dangerous because you are working above your head on a ladder.

## *SUB-FASCIA, FASCIA, & SOFFIT*

Sub-fascia, fascia, and soffit are used to box in rafter tails and close in roofs so that animals cannot get into the attic space.

Sub-fascia: covers the rafter tails and provides a surface to mount fascia too. Constructed of 2x lumber one size larger than that used for the rafters

Fascia: covers the sub-fascia, and is made of a 1x material, vinyl or metal.

Soffit: connects the bottom of the fascia to the side of the house, closing in the roof system.

## *INSTALLING SUB-FASCIA*

1. Determine lumber needed. Sub-fascia material is always 2x dimensional material.
2. Attach the sub-fascia to the rafter tails using 12d nails. There should be 2-3 nails per rafter. Split the end of the rafter when meeting lumber together.

## *INSTALLING SOFFIT*

All soffit should be installed perpendicular to the side of the house. Install after roofing is completed, and siding has been installed up to the bottom of the rafter.

1. Install F-channel along wall, the bottom of the F level will be even with the bottom of the fascia. Screw into house with 1" screws. At the end of the eave, fold the F-channel up so that it runs vertically up to the roof. This will make closing the corners very easy.
2. Measure from the trough of the F-channel out to the outside edge of the sub-fascia. Cut a piece of vinyl soffit ¼" shorter than this.
3. Insert one end of the soffit into the F-channel, bending it up to run vertically at the corner, and screw the other end into the bottom of the sub-fascia. Put the screw through the channel in the soffit.
4. Cut the next piece of soffit, and snap into the first piece. Continue inserting into the F-channel, and screwing every other channel into the sub-fascia.
5. On the rake edge, run the F-channel all the way down to the eave, and begin soffit at this low corner. This will box in the corner. When complete, the fascia will cover the screwed part of the soffit.

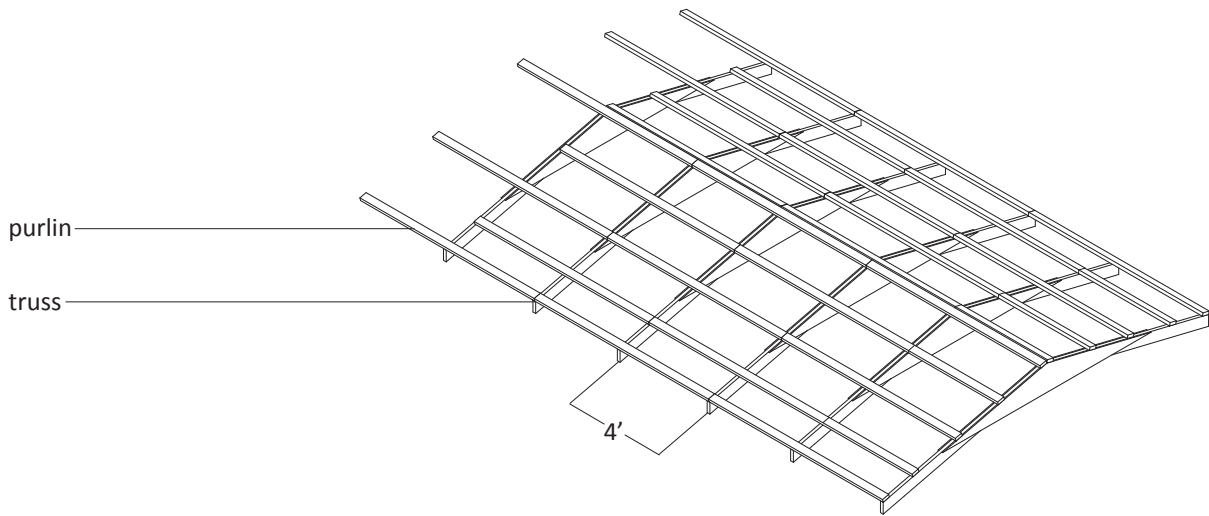

purlin

truss

4'

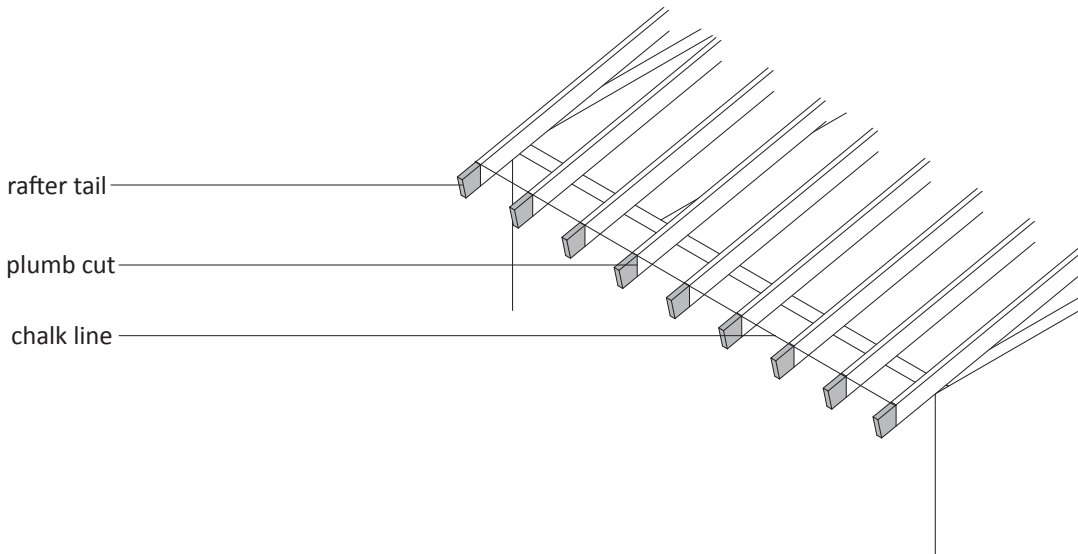

rafter tail

plumb cut

chalk line

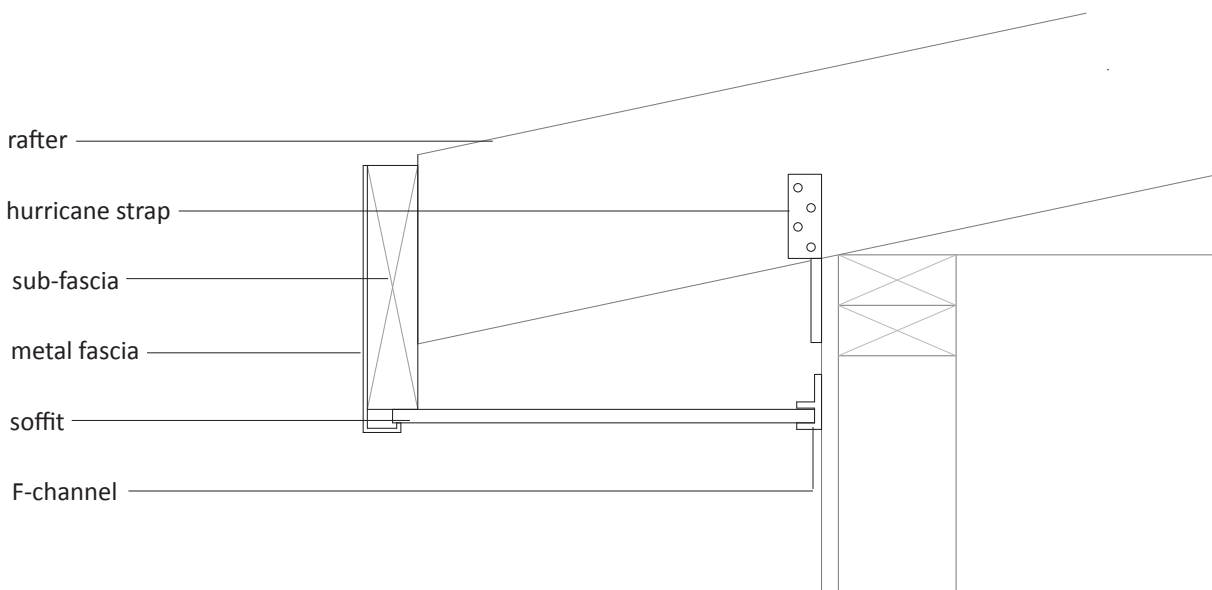

rafter

hurricane strap

sub-fascia

metal fascia

soffit

F-channel

## INSTALLING FASCIA

The best fascia to use is a metal or vinyl fascia because it is maintenance-free. Install after soffit.

1. Install the rake fascia first.
2. Slip the top of the fascia up underneath the drip edge if already installed. Making sure it is snug, use aluminum trim nails to face nail into the bottom lip to the bottom of the sub-fascia every 24". If using white gutter screws instead of aluminum trim nails, be sure not to over-tighten. Over-tightened screws will deform fascia.
3. Trim the fascia, and bend the last ½" around to the sub-fascia on the eaves.
4. Install the eave fascia in the same manner. At the corners, place an extra nail where the fascias meet one another, and also at the top of the fascia. This will keep it snug against the sub-fascia. Overlap seams by at least 1".

## DECKING THE ROOF

Decking- covers the roofing frame, typically made out of ½" OSB. If repairing on an older home, it may be made of 1x boards.

1. Complete all framing before beginning decking.
2. Mark 48" up the rafters from the outside of the sub-fascia. Snap a chalk line along these marks, as this will be the top edge of the first sheets of OSB.
3. Install OSB running lengthwise across the rafters. Seams will need to be staggered as you install each subsequent row of decking.
4. Between horizontal rows, use H-clips. Place an H-clip between each rafter.
5. All decking must end on a rafter. Never span less than 3 rafters.
6. When you reach the top, you may have to cut strips of OSB to fill in the last bit of roof.

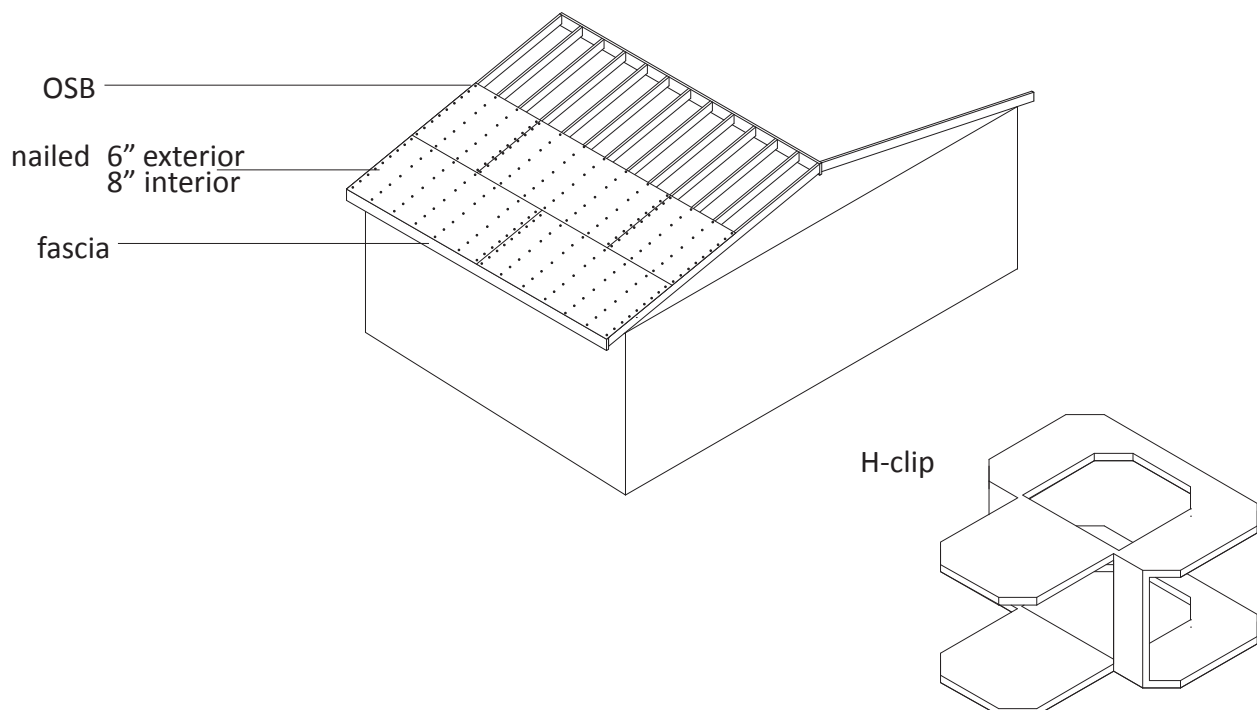

# ROOF COVERING

## ROOF SAFETY

### LADDERS

- Secure the ladder where it meets the roof with rope or wire to keep it from moving side to side
- Extend the ladder 3' above the roof line
- Always set up the ladder on even ground
- Always have somebody holding the ladder when in use
- 4' to 1' ratio—the ladder should be 1' out from the wall for every 4' of height

### HARDHATS

- Anybody working on the ground under a roofing project should be wearing a hardhat

### ROOF JACKS

- Roof jacks are REQUIRED on all roofing jobs
- Roof jacks should be installed at the base of the roof, secured by nails when attached to decking, and screws when attached to furring strips through the tin
- Three roof jacks per board is ideal
- One nail can go into the hole that sticks up into the edge of the board to keep it from sliding

### DANGEROUS CONDITIONS

- Wet roofs are very dangerous, do not go up a wet roof
- Sunny days create dangerous heat and sun glare on metal roofs, encourage more breaks on hot sunny days
- Dewy mornings sometimes leave a small amount of water on the roof—do not go onto a wet roof, or out to work on a roof early in the morning
- Sawdust can become very slippery on a roof, NEVER make cuts on the roof, cut material on the ground, and pass it up to the roof

### FALLING OFF/FALLING THROUGH

- Particularly dangerous areas of the roof should be marked
- Edges can be marked with small strips of wood with caution tape tied to them
- Weak areas that a person may go through the roof can be painted with bright colored paint
- Ceiling joists should not be a walking surface, slide additional boards in to stand on, and tack them in place if you need to stand in the attic
- Do not walk on individual rafters—**always walk on decking**

### BATS

- If bats are present, or evidence of bats is present, do NOT work on the roof

### POWER TOOLS

- A large variety of power tools will be used at various points while working on roofs
- Create a good, safe cutting station on the ground, in a place where materials can be most easily transported up and down the roof

## ROOF JACKS

Roof jacks are required on all roofing jobs. This includes tear-offs and replacements, both with shingle and metal.

If a roof is more than a 4:12 pitch, do not work on it without prior approval from ASP's Home Repair Coordinator, an ASP Program Manager, or an ASP Construction Consultant.

Do not work on a roof with an eave height greater than 12 feet, or a gable height greater than 20 feet, without prior approval from ASP's Home Repair Coordinator, an ASP Program Manager, or an ASP Construction Consultant.

### INSTALLATION OF ROOF JACKS

The roof jacks should be nailed into the rafters when possible. Put a nail at the top of each of the three slots. Do not drive the nail too tight or it will be difficult to remove the roof jack when the project is completed.

Place the flat portion (pointing up) on the roof 12" from the roof edge at the eave, with the J portion toward the bottom of the roof. They should be a maximum of 6' apart on the roof.

Put a 2x6 in the J portion, connecting the Jacks together and creating a ledge to catch anyone or anything that might slip down the roof.

When finished with the roof, simply remove the 2x6 and tap the bottom of the jacks up. The jack will slide off the nails and you can pull it from underneath the roofing material.

## ROOF COVERINGS

Roof coverings are what make roofing systems water tight. They protect and seal all roof elements that could be damaged by water, as well as keeping moisture out of the home.

## REMOVING ROOFING MATERIALS

When removing old roofing materials, ***only uncover a 10' portion of the roof at any time***. Start at one end of the roof and remove roofing materials from top to bottom and side to side. This will limit the risk of water and storm damage. Also, try to start on the most inaccessible side of the roof as this will limit the amount of people walking on new roofing material once installed.

1. Remove all shingles down to the decking using pry bars and shingle shovels. Try to park a truck or dump truck near the home so that it is easy to dispose of roofing materials.  
*Remember: when removing old roofing, only uncover one 10' portion of a roof at a time. Start on the least accessible side of the roof to limit people walking across newly installed roofing.*
2. Check the decking to make sure it is in good condition. If the decking will not solidly hold a nail, then it needs to be replaced. Also, make sure to check thoroughly for protruding nails, pulling out any that you find, as they will cause problems for you as new roofing material is applied.
3. ***Always have plastic ready to cover an open roof in case of rain. Do not neglect this, since storms often come suddenly.***
4. When your work is completed for the day, place a tarp across the roof. Wrap 2x4s around one end of the tarp and nail it into place under the eave of the roof. Pull the tarp across the roof to the other side, wrap the tarp end, and tack into place under the eave.



roof jack



drip edge

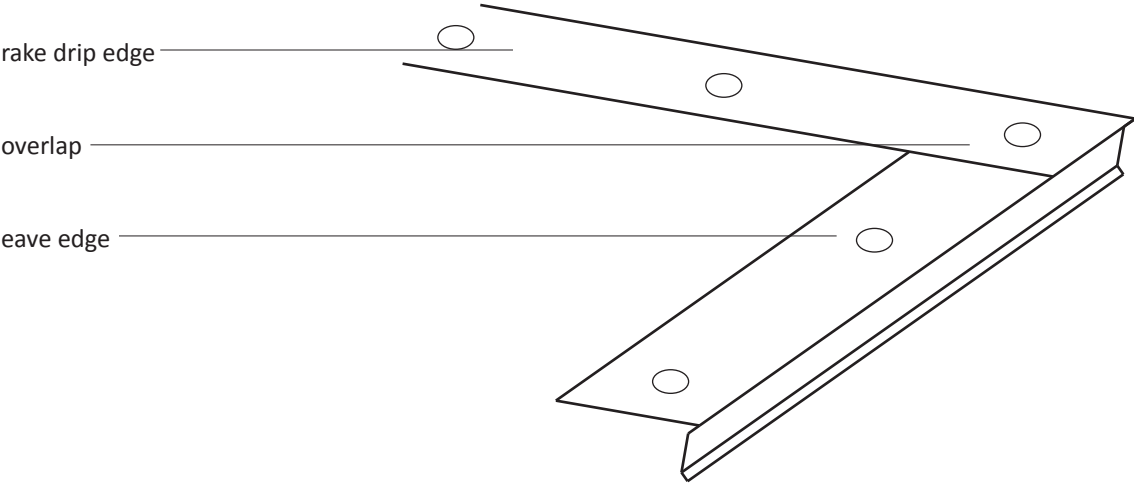

## INSTALLING DRIP EDGE

Drip edge is metal edging on a roof's sides and front to protect wood decking from absorbing moisture. Install drip edge in two steps:

1. Before installing the underlayment, install drip edge across the eave of the roof. The eave is a roof's bottom edge. The drip edge can be installed using roofing nails. 2"x2" is the size of flashing to use in this application. It is also called gutter flashing. Nail every 6" into the decking, making sure that the nails are not sticking up.
2. After installing underlayment across the roof, install drip edge over it on roof's rake to help hold the underlayment in place. The rake is the side edge, along the gable end. This should be fastened in the same manner as along the eaves. It is sometimes referred to as Style D or drip edge.

## INSTALLING UNDERLAYMENT

ASP is only using synthetic underlayment on roofs. Thirty pound (30 lb) felt paper can be used if synthetic is not available. Fifteen pound (15 lb) felt paper will not be used under any circumstances.

Synthetic underlayment—such as Feltex, Titanium, Rex or Grace—is the ASP approved choice in place of felt. It can be purchased where the metal roofing is purchased. One roll covers 1000 sq ft. It is easier to install, does not distort with exposure to weather, and will last for months without covering with metal roofing. Follow manufacturer recommendations regarding application (it is similar to felt). If the roof is covered correctly with synthetic underlayment, plastic does not need to be used to cover the roof. ***Do not use plastic caps or bottle cap nails under a metal roof as they will distort the metal.***

1. If the roof has a valley, install ice and water shield in the valley first. Run it the distance of the valley, followed by rolled metal and underlayment perpendicular to the valley. Install rows of underlayment to overlap the valley 6" with three nails fastened to the end of each row. Do not nail within 6 inches of the center of the valley thru any product you are using.
2. Starting at the eaves, roll the underlayment across the roof, going parallel to the eaves. Nail with roofing nails in every marked hole, and make sure to overlap the next piece. Follow all marked instructions on the underlayment.
3. When you reach the top of the roof, simply flap the extra over to the other side. If need be, tack it in place to keep the roof dry while working on it.

## SHINGLING A ROOF

*NOTE: ASP is not using asphalt shingles on any new or replacement roofs. Shingles will only be used to repair existing roofs. ASP is using metal roofing—or SBS Modified Bitumen roofing—because of their longevity and ease of installation.*

Follow manufacturer recommendations when shingling. Directions can be found on the shingle packaging.

1. To begin shingling, remove the tabs of enough shingles to line the roof's edges. This will form the starter strip. Use a utility knife to cut the tabs off, and install the starter strip with the tar strip along the eave. Precut starter strips can also be bought at the supplier.
2. Overhang the starter strip by ¼", starting along the eaves, and then along the rake. Nail above the tar strip, placing 4 roofing nails into each piece.
3. Overlap the shingles on the corners, with the rake starter strip on top of eave starter strip.

underlayment

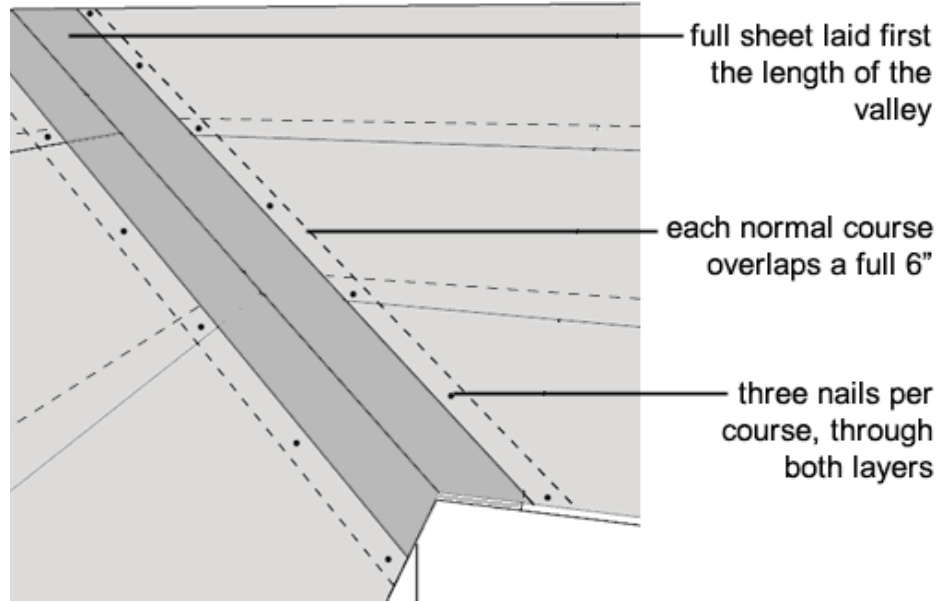

3 tab shingle

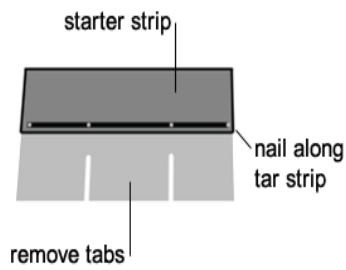

starter strip

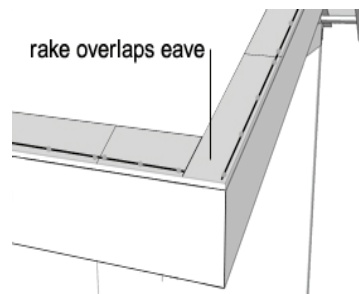

4. Begin your first row of shingles directly over your starter strip. Nail each shingle above the tar strip with four roofing nails.
5. Stagger the next row of shingles, offsetting by half a tab. To stagger seams on three tabs, cut the shingles according to manufacture recommendations. A small slit on the top of each shingle indicates where to cut. Overlap the top row over the tar strip of the preceding row as this will help keep the shingles in place over time. (*Staggering the seams as rows of shingles are installed helps to prevent water from traveling between the tabs of two rows and onto the underlayment.*)
6. Install shingles with 1¼" nails. 1½" nails are used on the ridge cap.
7. With first row installed, snap a chalk line (yellow shows well) on the underlayment to indicate where second row will end.
8. Shingles are typically 12" tall. Expose 5" and cover 7" with the next row of shingles.
9. Mark both ends of the roof and snap your line before installing each subsequent row. Every five rows should be measured and chalked. This keeps the roof moving up uniformly. When the roof is about ¾ finished start measuring from the ridge down. That way the shingles will end uniformly at the ridge. *If shingles are installed out of line, do not correct this error in one row. Gradually correct error through the next several rows of shingles.*
10. The "eye" appeal will be greater if the ridge cap covers with the same reveal on the shingles the length of the roof. Very few roofs have the same measurements from the ridge to the eave at opposite ends. If the measurement is taken from the ridge, and the eave, the finished roof will not look crooked.
11. The roof will be either capped with shingles or with a ridge vent/ridge cap. A ridge cap can be purchased or cut from 3 tab shingles. (To make a ridge cap, diagonally cut each tab as seen to the right)
12. Begin installing a ridge cap on the less weathered end of the roof overlapping the tabs of the last row of shingles. Shingle into the wind. If prevalent wind direction is from the North, start at the South.
13. Nail the first shingle down at the ends farthest from the rake. Use two dabs of roofing cement to hold the ends toward the rake in place. The second cap will cover the nails of the first one.
14. Install subsequent caps the same way, but without the dabs of roof cement.
15. The last cap of the roof will have two nails exposed. Cover these nails with roofing cement.
16. For more information on ridge vents see the section on VENTING.

### PIPE BOOTS AND VENTS

1. When shingling around a pipe or vent, shingle up to the obstruction. Once the shingles are in place, slide a pipe boot over the pipe/vent, setting it in place.
2. Tack two nails into the top of the boot flange, above the shingles.
3. Once the boot is in place, shingle over the top half, so that the bottom half of the boot is exposed and the top half of the boot is covered.
4. Shingling must be cut to fit when covering the top part of the flange (as shown).
5. If a flue or "B Vent" is bumped on the roof, it is important to check inside of the house to make sure it has not been disconnected from the appliance or heating device. Please talk with ASP Headquarters or an ASP Construction Consultant before attempting to do anything with it. Safety first!

shingle layout

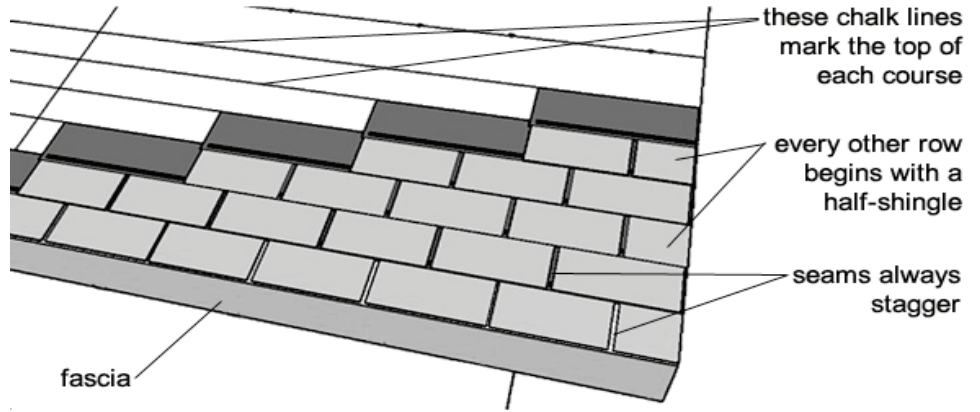

cutting for ridge cap

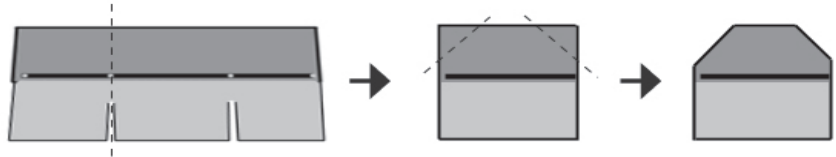

ridgecap

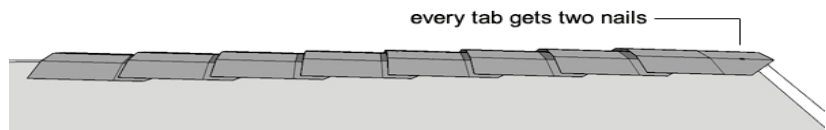

pipe boots

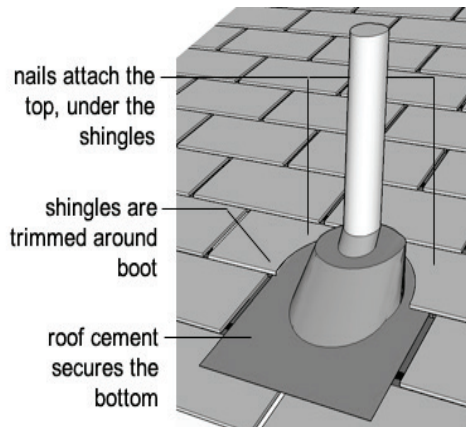

## VALLEYS

When two roofs join at an angle, a valley is formed. Shingling a valley must be done carefully, since in this area an improperly laid roof valley can easily develop leaks.

1. Lay a strip of ice and water shield the length of the valley, followed by a layer of valley metal the length of the valley, and followed by another layer of synthetic underlayment.
2. Nail down material on the outer edges only; making sure that it lays flat throughout the valley.
3. Shingle the roof, being careful not to nail into the valley.
4. When shingling, let one side of the roof carry over onto the other face of the roof. Let the next side carry back and cut the top course down the center of the valley. This will give a "closed" valley, and improves the longevity of the valley.

## CHIMNEY FLASHING

Chimneys are one of the most common areas for roof failure and leaking. Properly flashing a chimney requires the use of step flashing and cap flashing. If the chimney is no longer used, consider removal to below the roof line.

1. Shingle up to the bottom edge of the chimney as if you were shingling around a vent. Install flashing on the down slope side of the chimney going over the shingles and tight to the chimney.
2. Once the flashing is installed on the down slope side, install the first step flashing over the first row of shingles. Step flashing should overlap the chimney by at least 3" and overlap the shingle by at least 4".
3. Weave the shingles over the step flashing, overlapping the flashing by two inches. Once the step flashing is installed, caulk the top of the flashing with a heat resistant caulking.
4. Counter flashing should be installed over the top of the flashing on the chimney to prevent water from getting behind the step flashing.
5. To install counter flashing, the mortar joints in the chimney need to be cut with a masonry blade. The counter flashing is installed in the joint and is bent over the step flashing. (Counter flashing should stop 1 ½" above the roof.)
6. Point-up the joints with new mortar, or fire resistant caulk where the counter flashing was installed, to secure it.

valley

18" of flashing or ice shield goes on first  
36" of synthetic underlayment goes on next

shingling cannot continue until the valley is complete

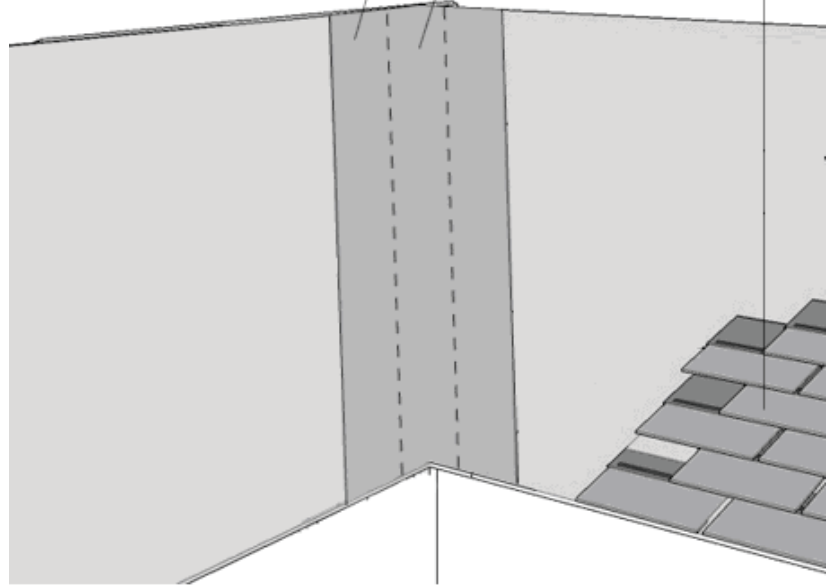

chimney flashing

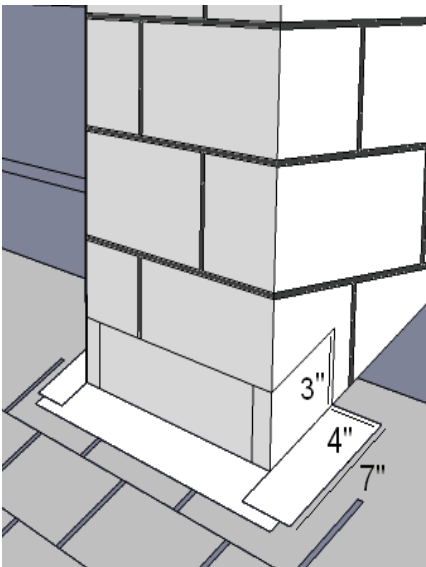

1

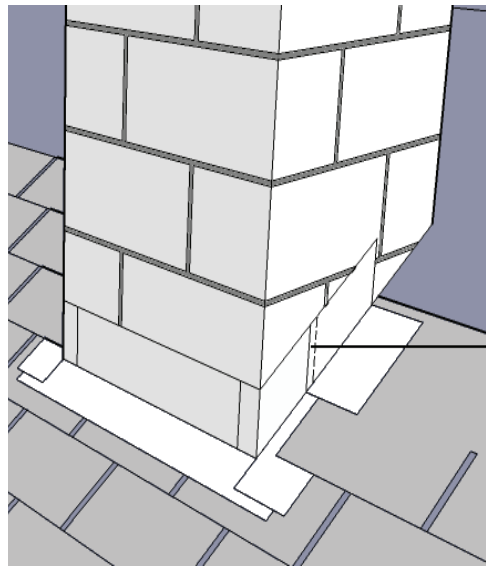

2

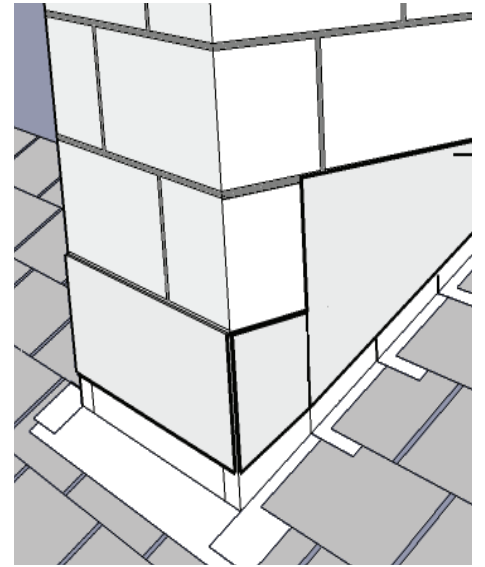

3

## CRICKETS

Crickets are non-structural roof members that allow water to slope away from larger chimneys (18" or wider). They are built out of 2x4s and plywood/OSB. **Crickets are not required when using metal roofing.**

### NOTES:

- A cricket is attached above and directly to the decking with 12d nails.
  - The cricket should be built out of 2x4s and sheathed with 1/2" OSB.
  - The cricket should never directly touch the chimney. The framing should be at least 1" away from the chimney.
  - The cricket height needs to be half the width of the chimney. The cricket framing should end 1" short of the end of the chimney. This allows the decking to end at the edge of the chimney.
1. Determine the angle of the cut needed for the "ridge" of the cricket. This can be determined by the slope of the roof. Cut this angle, and trim the "ridge beam" to the correct length. Determine the angle of the "rafters" that need to be cut. Cut the "rafters" with a compound miter saw.
  2. Attach the cricket to the roof with 12d nails and sheath with 1/2" OSB
  3. Cover the cricket in flashing. Use 12" flashing to cover the valleys of the cricket. Flashing is then overlapped on top of the valley flashing, covering the entire cricket. The flashing should be bent, to allow the flashing to overlap the chimney by at least 2".
  4. Once the flashing is installed, cover the cricket with "ice and water shield"
  5. Cover the cricket with shingles woven overtop of it.
    - To do this, weave the shingles perpendicular to each other.
    - Shingle the roof to the cricket.
    - Allow one row of shingles to overlap the cricket.
    - Place a shingle perpendicular to the roof shingles, overlapping the shingle on the cricket.
    - Weave step flashing into the cricket shingles, just as it would on the sidewall of the chimney.
    - This process is repeated with another row of roof shingles installed, with the final shingle overlapping onto the cricket, and another shingle being installed on the cricket perpendicular to it.
  6. A cap is placed over the shingles at the ridge. The last cap may need to be cut down the middle to allow the transition to the roof. A full roof shingle covers part of the final shingle cap.
  7. Once the cricket is shingled. Install counter flashing over the step flashing. The counter flashing should overlap the corner of the chimney. Cover the seams with heat resistant caulk.



cricket construction

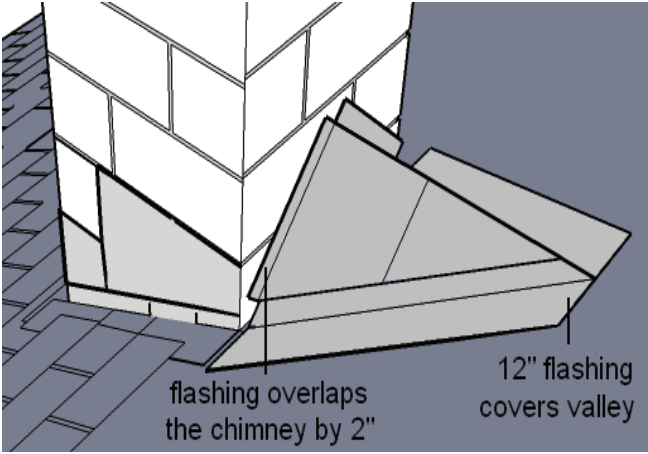
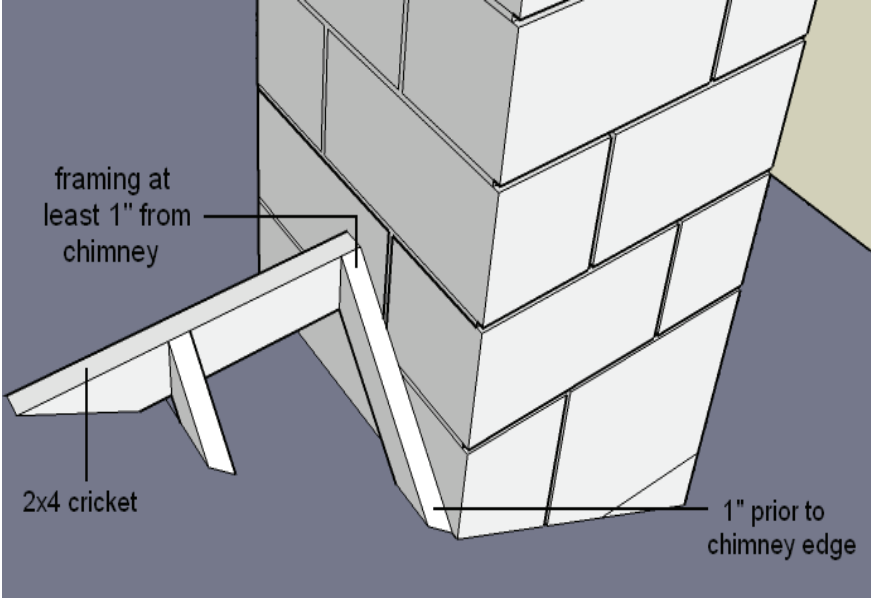

sidewall flashing

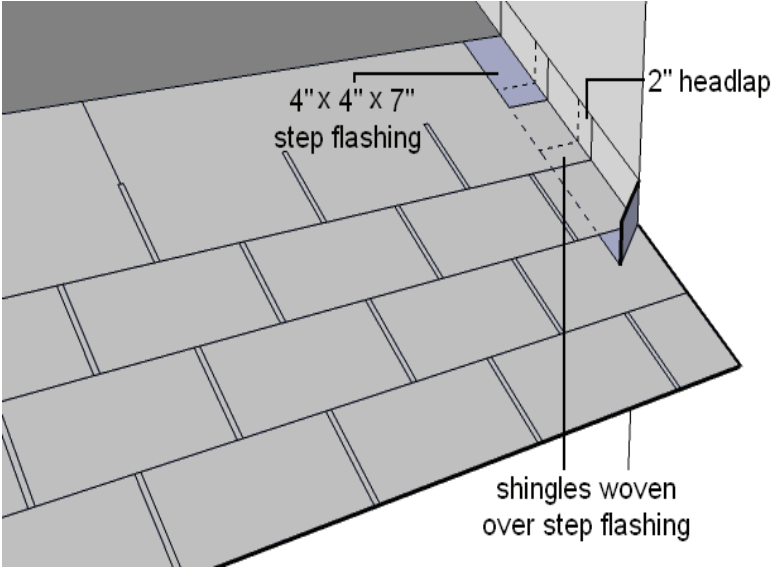
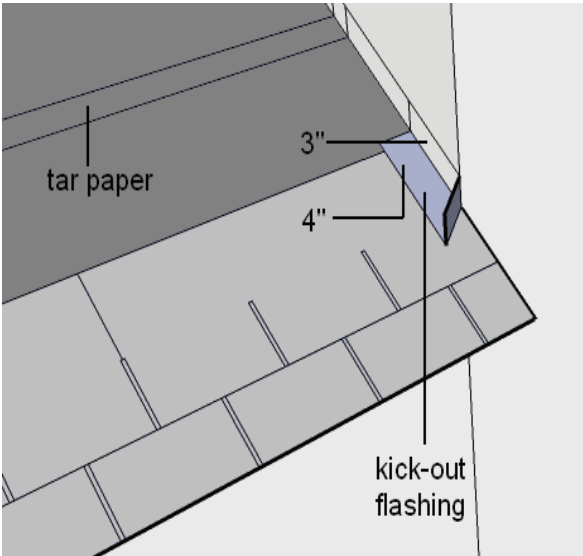

## SIDEWALL FLASHING

1. When shingling against a sidewall, step flashing is required to be run against the sidewall. This process is similar to that of step flashing along a chimney.
2. When covering the roof, the synthetic underlayment should be rolled up the sidewall a minimum of 2"
3. Shingle to the sidewall
4. Place the first piece of flashing on the sidewall. Extend it out past the sidewall at least 5" and then bend it so that it forces the water towards the center of the eave. (This is sometimes called "kick-out flashing". This flashing kicks away from the wall to prevent water going behind the siding.)
5. Lay the next row of shingles, overlapping the flat part of the flashing
6. Another piece of flashing laps over the first row of shingles, with a minimum of 2" overlap
7. Continue this process until the entire sidewall has been flashed
8. Caulk the joint between the step flashing and the sidewall
9. Install housewrap over the top as well
10. The siding should cover the flashing, allowing for a 1" gap between the bottom of the siding and the roofing material

## FLAT ROOFS

For ASP's purposes, a flat roof will be considered to be any roof with a slope less than 2/12.

ASP does not use 90 lb rolled roofing on any roofs. With proper planning, a self-adhering SBS Modified Bitumen cap sheet roof product (such as Mule-Hide or Certainteed Flintlastic SA) can be ordered and installed. It is a peel-and-stick system that is easy to install and lasts longer than 90 lb rolled roofing.

**Contact the Home Repair Coordinator, the Warehouse Manager, or a Program Manager at ASP Headquarters to order these products.**

SBS material is a rolled roofing product that has a predefined overlap. There will be a 2" to 4" section of the product that does not have any granulation on it. This goes toward the top of the roof, and each succeeding roll overlaps that strip. This is similar to the application of synthetic underlayment. **NO NAILS ARE NEEDED WITH SBS MATERIAL.**

The SBS product is a "peel and stick" product. You "peel" a protective coat from the back side of the roll and then "stick" the roll down. This protective strip is split at 18" when it comes from the factory. You will start at the bottom of the roof and work your way to the top, with each sheet overlapping the one lower down on the roof. Or, if you are working on a mobile home, start at the end.

Sticking this sheet down without wrinkles—and without sticking to the person installing it—is challenging.

**Note: Certainteed has a base sheet to be used under Flintlastic, but it is hard to obtain in rural areas. Therefore, ASP uses synthetic underlayment under Flintlastic. Felt paper is NEVER used under SBS material—only synthetic underlayment.**

SBS layout

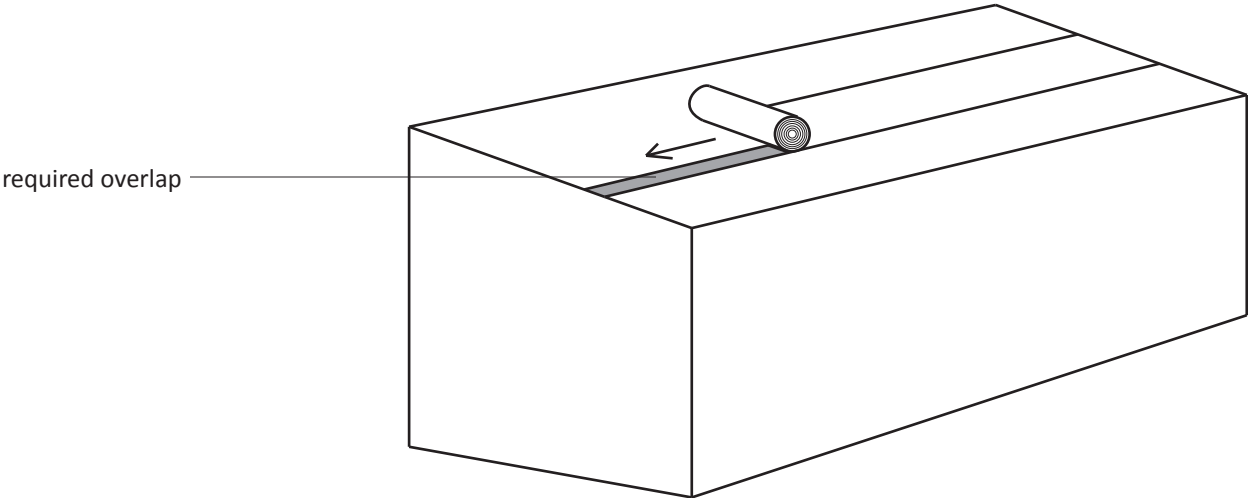

valley

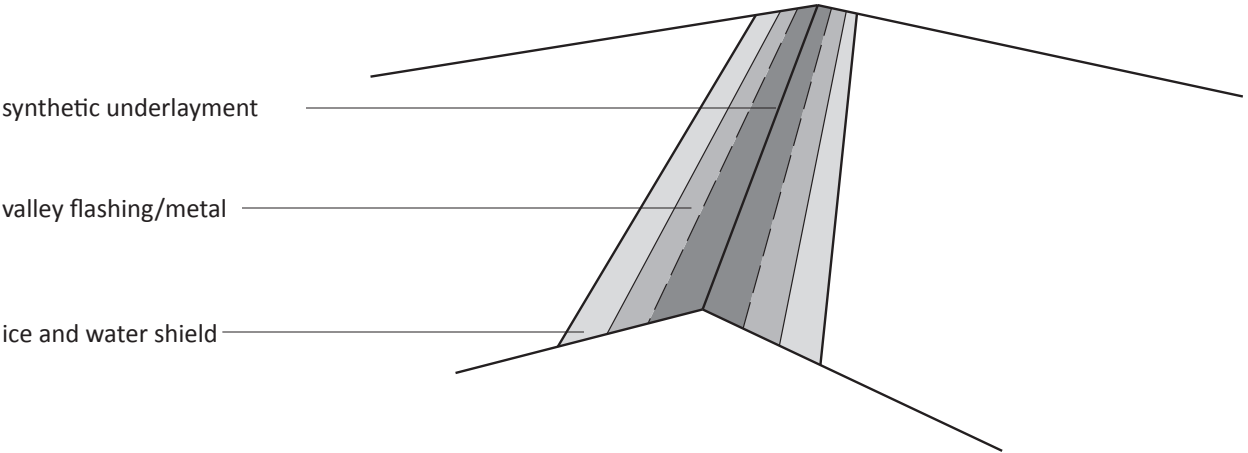

1. To prep a flat roof we use some of same the procedures as for a pitched roof. Strip the old shingles and check the soundness of the decking.
2. Install synthetic underlayment ovetop of the decking, doubling the nailing pattern laid out on the underlayment. **MAKE SURE THAT NAILS ARE FLAT TO THE ROOF. IF NOT, THE NAILS WILL PUNCTURE THE SBS MATERIAL.**

**NOTE: THE INSTALLATION OF THE SYNTHETIC UNDERLAYMENT IS JUST AS IMPORTANT AS THE SBS INSTALLATION.**

**WHEN SBS IS INSTALLED OVER TOP OF SYNTHETIC UNDERLAYMENT, THE FASTENERS HOLDING THE UNDERLAYMENT DOWN WILL ALSO BE HOLDING THE SBS IN PLACE. IF SBS IS TO BE INSTALLED ON ALL NEW DECKING, SYNTHETIC UNDERLAYMENT IS NOT NEEDED BECAUSE THE NEW DECKING WILL ACCEPT THE SBS DIRECTLY.**

3. If needed, install sidewall flashing to run up underneath the sidewall siding (see SIDEWALL FLASHING)
4. Install drip edge all around the perimeter of the roof, with the rake and top eave over the underlayment, and the bottom eave under the underlayment
5. Sweep the entire roof free of any debris. This is crucial in getting good adherence of the roofing product
6. One of the easiest ways to apply the product is to pre-measure, and cut the length that you need on the ground, and then bring that piece up on the roof. You will need to trim around any roof obstructions (chimneys, pipes, etc.)
7. Roll that piece out horizontally on the roof starting at the eave edge on the roof where you want it. Do not take the protective cover off yet.
8. Flop the bottom half of that roll up on the roof over the top half along the entire length of the piece.
9. Remove the first 18" of protective covering and flop the bottom back onto the roof. Your roll is now held in place.
10. Now, flop the top half over the bottom, remove the protective sheet and flop it back onto the roof. Your first sheet is now attached.
11. Smooth out the surface with a hand roller so that there are no lumps/bubbles
12. Continue this process until the roof is covered, starting at the bottom and moving toward the ridge, smoothing each piece as you go. Each piece will lap over the previous one, creating a water tight seal. *Follow the instructions included with the roofing product regarding the amount to overlap. Let the SBS run over the ridge by 6" on each side of the roof.*
13. When the entire roof is covered, re-roll all seams as well as the edges of the roof along the drip edge
14. Install any needed pipe boots and caulk, making sure to use neoprene fasteners and silicone caulk/roof tar
15. If joining a pitched roof, allow SBS to carry at least one foot up the pitched roof. Then cover SBS with metal/tin.
16. The SBS will not adhere directly to shingles (or any roof with granulations). In this case additional roof mastic is required at this seam to adhere SBS to roof.

## VALLEYS

Covering valleys on a flat roof is similar to covering valleys for shingles.

1. First, place a piece of synthetic underlayment in the valley, working from the eaves to the top of the ridge. Follow this with valley metal (at least 18"), and a strip of ice and water shield.
2. Nail down flashing on the outer edges only; making sure it stays flat in the valley.
3. Make a closed valley similar to the type recommended for shingles.

## MOBILE HOME ROOF REPAIRS USING SBS MODIFIED CAP SHEETS

We are currently using two different application methods to repair Mobile Home roofs using a SBS cap sheet. Both methods have the same preparation requirements, many of the same steps and both have the SBS going from side to side, and not parallel with the long side of the trailer. The SBS is white for energy savings.

The purpose of the termination bar is to hold the cap sheet tight against the mobile home to prevent wind from getting under the SBS material.

- SBS Modified Bitumen roof system: A rubberized flexible roofing cap sheet used for low-slope applications. It is self-adhering.
- Termination bar: Galvanized or aluminum flashing used to attach the SBS to the eaves and gable ends of mobile homes. It is 1" wide, and is attached with neoprene backed screws.

## COMMON AREAS

- Make sure that pieces of sheathing are on site to spread the weight of people on the roof. The sheathing should be long enough to span 2 trailer trusses, and wide enough to work comfortably from. Do not work on the roof without sheathing to kneel on
- There should be a maximum of 2 people on each side of the roof at any one time
- Sweep and clean the roof
- Paint the roof with an Oil-Based primer such as Kilz Original interior or exterior primer (let dry at least 12 hours)
- Bend/pound the existing J channel on the eave edge of the roof out and down so that the surface is reasonably flat (the termination bar will go flat against the trailer in this area)
- Measure to determine the length of SBS material that will be required.
- Measure and cut all pieces on the ground
- The termination bar is applied in the same 2 places with both methods; at the eave edge and on top of the cap sheet, at the gable ends
- Caulk is applied to the termination bar in the same place and amounts
- The roof penetrations are dealt with in the same manner with both methods
- The whole roof needs rolled down with the small, hand held rollers, with particular attention given to the lap seams. **Do not try to bring a heavy roller on to the roof.**

- The SBS material is dry fitted before any plastic film is taken off of the back and off the lap, with the black strip of the product always on the inside. The next strip adheres to this strip
- If the material is going to be applied to the granulated surface (such as a patch or a penetration), roof mastic (such as wet patch or Blackjack) must be used between the surfaces, and rolled thoroughly

### VENTS

- If the vent does not have a top on it; measure carefully where the vent will come through the cap sheet, cut a hole in the sheet and slide it down around vent and then put roof mastic around the pipe and over the cap sheet. The mastic is what will shed the water so be generous. When this is done, put a standard pipe boot on top of the sheet, put mastic between the boot and the cap sheet and screw the boot into the roof.
- If the vent has a top on it, a different method is used. It is better to not try to remove the top/cap as the screws are usually so rusted that you can't remove them anyway. In this case, find where the pipe will come through the cap sheet and cut a hole big enough for the vent. Then, cut a slot to the nearest edge of the sheet, and slide the cap sheet around the vent and into place where it will sit on the roof. Put mastic around the vent.
- When this is done, cut a piece of roofing that is 12" wider (on all sides) than the vent. For example, if the vent is 6" wide, the patch will be 30"x30".
- Cut a hole out of the center of the patch that is the size of the vent. Put a slit in the bottom of this patch and slide it over the vent, making sure that the slit is on the bottom of patch. Make sure that the protective plastic is removed, apply a generous amount of mastic and roll the patch down onto the roof. Apply another generous coating of mastic to the top of the patch and around the pipe.

### VALLEYS

Covering valleys on a mobile home roof is similar to covering valleys for shingles.

1. First, place a piece of synthetic underlayment in the valley, working from the eaves to the top of the ridge. Follow this with valley metal (at least 18"), and a strip of ice and water shield.
2. Nail down flashing on the outer edges only; making sure it stays flat in the valley.
3. Make a closed valley similar to the type recommended for shingles.

*(This page was intentionally left blank)*

## *TWO PIECE SYSTEM*

- Find the center (ridge) of the home at both ends and snap a chalk line between these points.
- Measure from this line to the edge of the home and add 8" (2" for the eave edge and 6" for the ridge cover)
- Cut the length on the ground
- Dry fit the first piece; lined up with the gable end of the home with the ungranulated edge on the inside (about a 4" wide black strip)
- When in place, fold one side back and remove the protective plastic and gently roll that piece back, being careful not to have any creases or wrinkles
- Next fold the other half of the cap sheet back, remove the plastic and lay that side back onto the roof.
- Roll this piece down using the rollers.
- Dry fit the next piece, making sure it is lined up over the strip without granules, remove the plastic and proceed with the process.
- Make sure that the thin film on the black strip is removed before sticking the 2 pieces together
- Once the pieces are placed together it is not possible to readjust the pieces, so be careful.
- Roll this joint together carefully and thoroughly. This is the most important joint.
- Continue on with the rest of the home.
- After 4 pieces have been attached to the roof you can start putting the termination bars on.
- Put a strip of caulk on the back of the termination bar and screw it into the trailer. Fill all pre-punched holes in the bar with screws with neoprene washers
- Attach a termination bar on top of the cap sheet at both gable ends.



Method used by less experienced volunteers

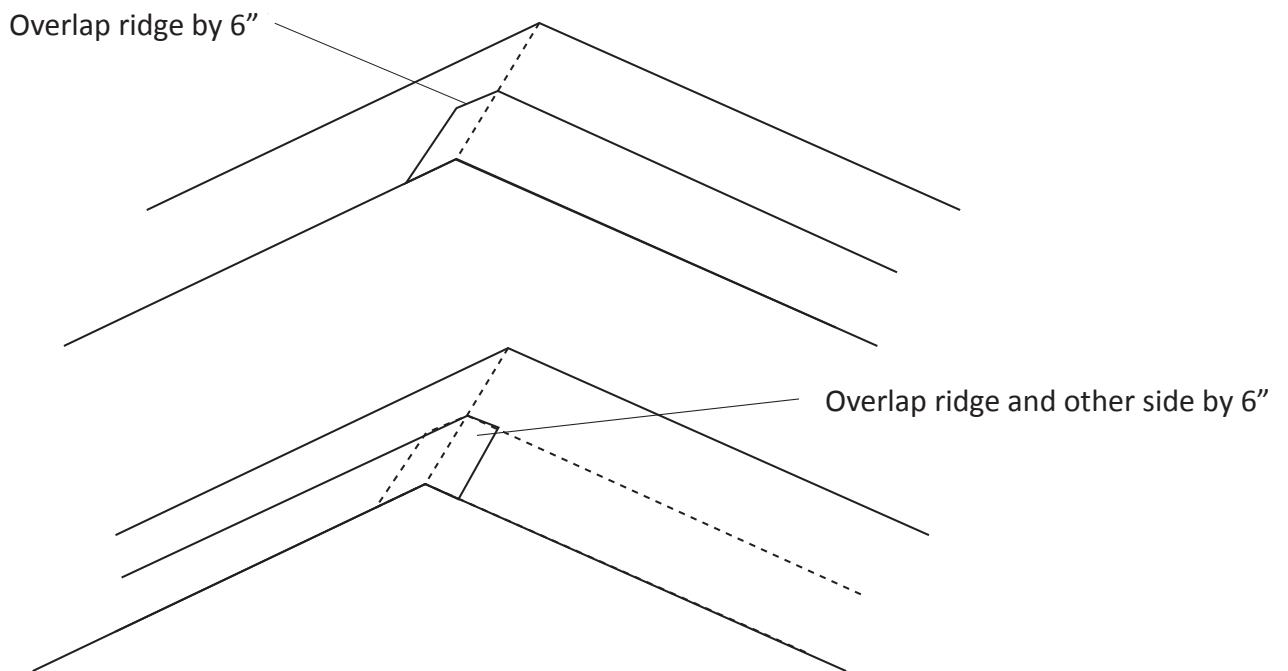
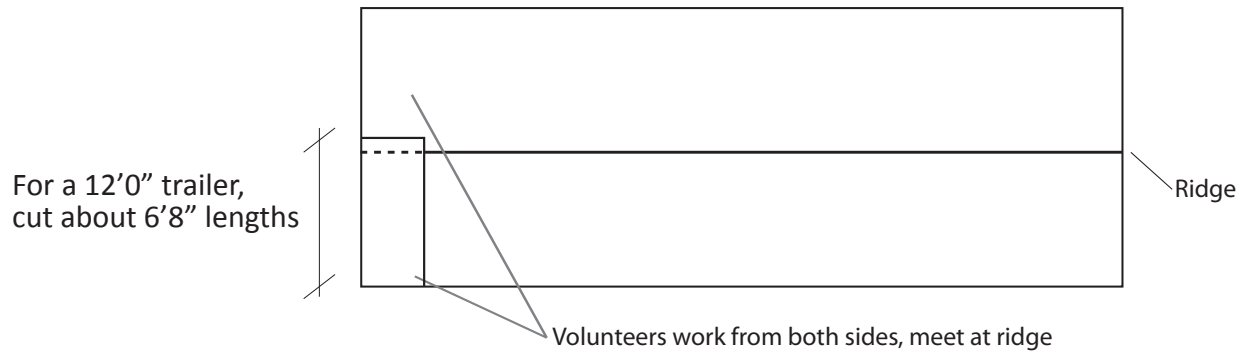

### ONE PIECE SYSTEM

- Follow the above steps with the exception of the measurements. With this method, measure from side to side and add 4 inches for the eave overhang
- Once the piece is dry fit, it is not as easy to flop the piece over because of the curve of the roof
- Gently pull the protective piece off and roll the strip in place, with special attention given to where the pieces join.

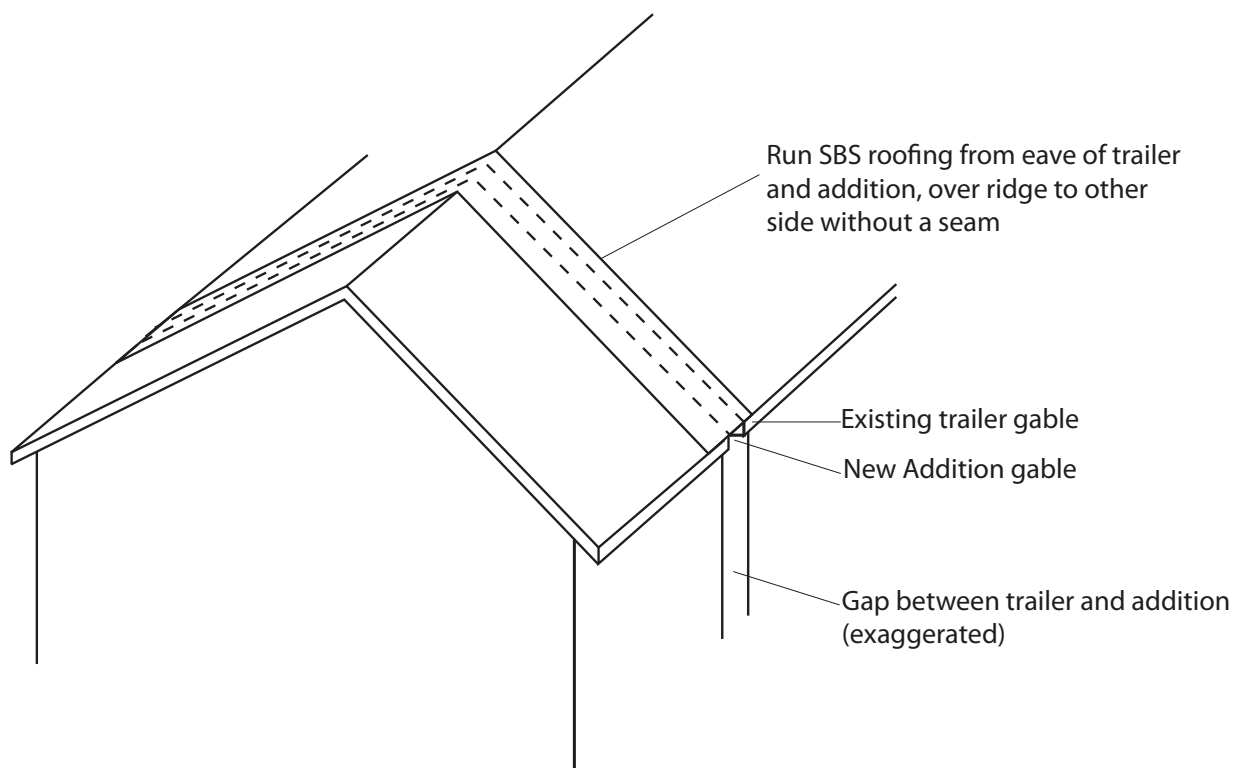

**THIS METHOD FOR EXPERIENCED VOLUNTEERS ONLY**

One piece of the SBS cap sheet

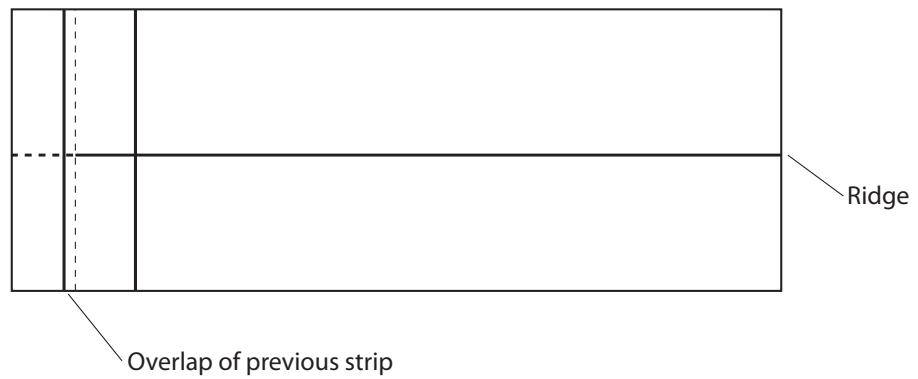
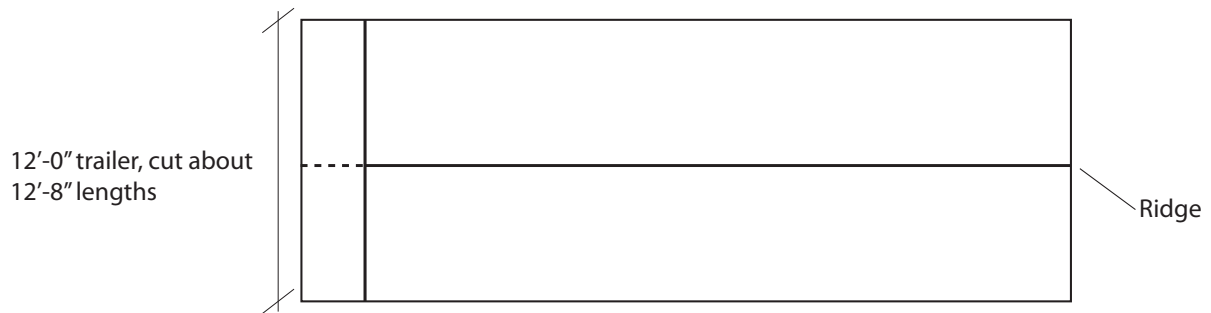
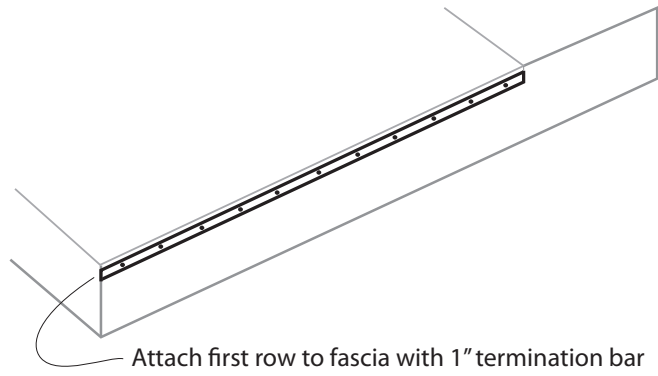
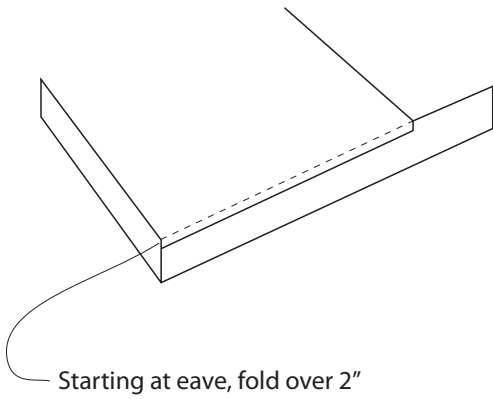

## METAL ROOFING

When working with any kind of sheet metal product, make sure to use proper safety. You must wear heavy leather gloves—NOT THIN COTTON GLOVES.

ASP is shifting to D ribbed panel roofing (names like Masterib, Propanel). It comes in 36" wide sheets, various lengths and various colors. It is thicker, easier to work with and is usually less expensive than 5 V tin. Follow manufacture recommendations for installation requirements.

(5 V tin: a galvanized metal with five ridges, two on each end and one in the middle. It comes in 25 ½" sections with a finished face of 24".)

### ROOF PREPARATION

1. Install metal roofing over solid decking or purlins a maximum of 24" on center. Solid decking is always safer and easier to work on. Check manufacturer's recommendations.
2. Install synthetic underlayment unless you are using purlins

### FASTENING METAL ROOFING

Proper fastening is the key to success when installing metal roofing. Take care to ensure that the roof is properly secured. Follow manufacturer directions.

1. Neoprene screws are used to fasten metal roofing into place. Do not overdrive screw heads. The gasket of the screw will become crushed, and cause the seal to prematurely break down.
2. Pre-drill holes prior to screwing down the tin. This will prevent screws from slipping or scraping the galvanized finish, as well as making installation easier and safer. (*Note: This should be done on the ground, drilling multiple panels at once.*)
3. Fasten metal roofing every 24". They will be fastened in the flats, next to the ribs.
4. A screw will be placed at the beginning of each overlapped panel and on the opposite side of the middle ridge. The screws should be approximately ½" from the rib. **Never place a screw in a rib.**
5. All eaves and overlaps require four screws, placed equidistant apart.

ridge cap

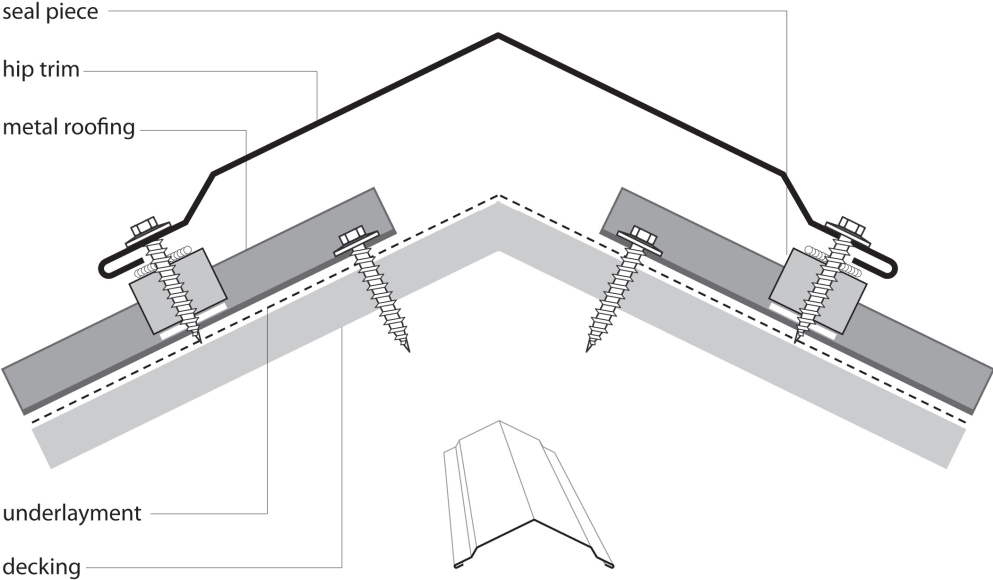

metal valley

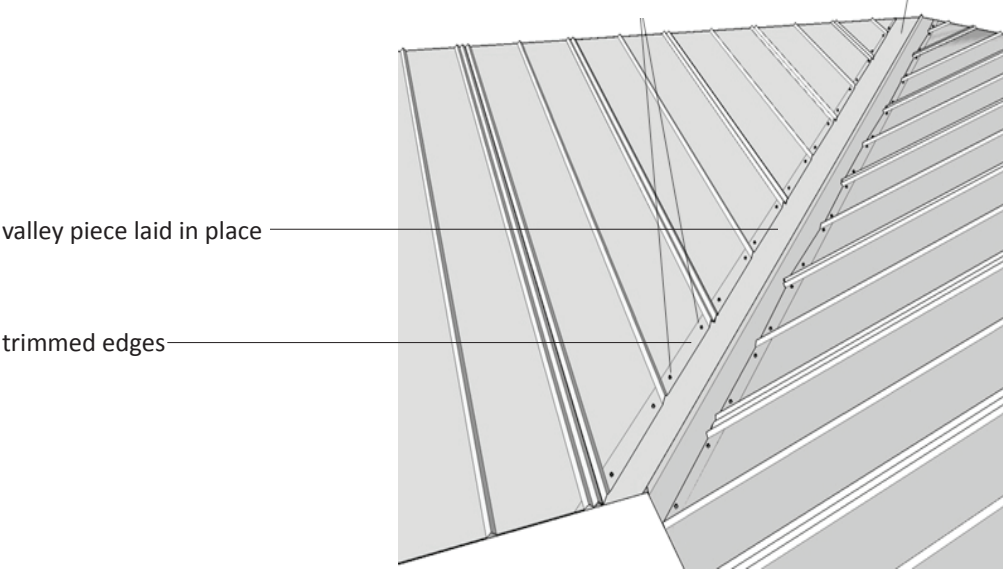

## INSTALLING METAL ROOFING

When installing metal roofing, there is a correct way and an incorrect way to overlap the panels. Make sure you follow instructions carefully and overlap the sheets properly.

1. To install metal roofing, start with the small rib parallel with the gable, and the larger rib out in the field (on the main portion of the roof). Begin on the roof's least weathered side and work across the roof. Work into the direction that the worst weather, or wind, comes from. If the wind generally comes from the west, start on the east edge of the roof and work toward the west. *This way, the overlap of the metal will allow the wind to go over the top, and not catch under the lapped edge of the metal.*
2. Lay the first sheet of tin and check to make sure it is square before fastening. Try to get it parallel with the gable, and perpendicular with the eave. This important step guides the entire roof's alignment.
3. Be sure the tin extends 2" beyond the eave and is 2" down from the ridge.
4. Screw it into place, making sure not to over- or under-drive the screws. It is best to install the screws near the top to hold the panel in place.
5. When installing metal it is important that the ribs are placed properly. The small rib will always overlap the larger rib. This will prevent siphoning of water between sheets, and the smaller rib holds the larger in place.
6. If tin is not long enough to cover the entire length of the roof, overlap two sheets.
  - Place the bottom sheet first, followed by a top sheet with an overlap of 6".
  - Do not screw through both sheets of metal. Instead, install four screws above and below the overlap.
7. When you are finished with the installation of the panels, you can clean up the edges of the eaves by snapping a chalk line and trimming the pieces with tin snips or electric shears. But if possible, it is best to avoid trimming.

## EDGE PIECES

After installing the panels, edge pieces are required to seal in the edges of the metal roofing.

1. Install rake edge along the rakes of the roof along all flat seams. Use neoprene screws here as well.
2. Rake edge is usually 10'3" so make sure to account for this when planning/installing. If need be, overlap the ends just as you would overlap metal roofing panels, starting with the bottom piece and working your way towards the ridge.

## RIDGE CAPS

Ridge caps for metal roofs are typically 12" wide, and come in standard lengths. Check with your manufacturer for specifics.

1. If needed, trim the decking back 2"-3" on either side of the ridge. This will allow for proper air flow.
2. Start on the roof's least weathered side and install the cap. All cap sections need a minimum overlap of 6".

3. Lay out the first piece and insert the vented foam enclosure strips between the ridge cap and the panels. This will ensure proper air flow, as well as keep any water from being driven back in the opening.
4. Place foam enclosures on both ends of the roof under the ridge cap.
5. Screw the ridge cap into place every 3rd rib, making sure to go through the **ribs** in the metal panels, not into the flat portion of the metal. *This is the only location where screws should be installed through ribs.*

## VALLEYS

Where available, order valley pieces from your metal roof manufacturer. As with any step in the ordering process, they are there to help you know what you need.

1. Install ice and water shield.
2. Lay the valley strip from the eave to ridge, fastening in place as far from the center of the valley as possible. The valley should be exposed at least 3" on either side when completed.
3. Install metal panels, making sure to leave the valley exposed. Screw through both the metal panels as well as the valley tin, still following manufacturer's recommendations.

## FINISHED PRODUCT

When you think you are finished, please review each step carefully. Check to make sure that screws are properly driven. Test valleys. Inspect the ridge and rake edges. You want to ensure that the roof will last for a long time, keeping the family safe and dry.

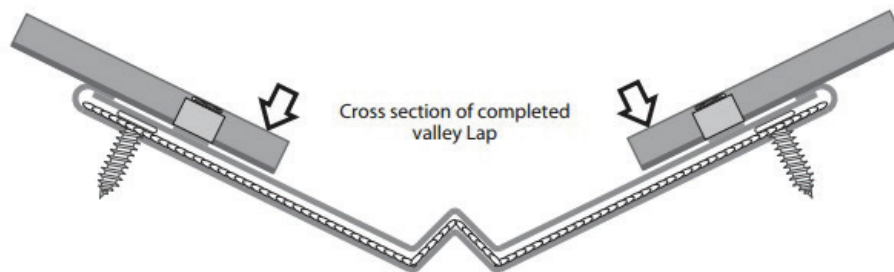

## FASTENING PATTERN

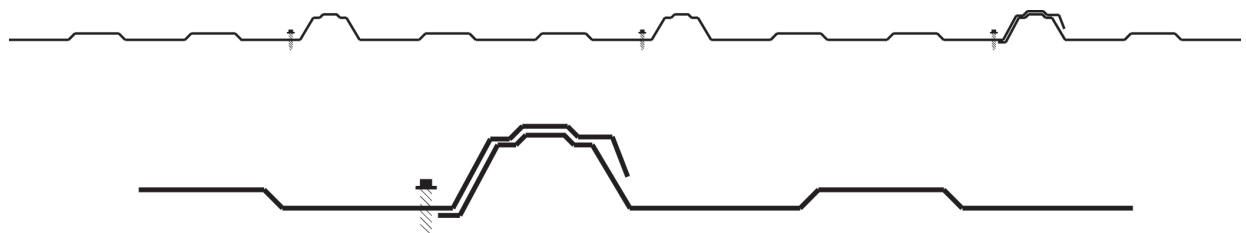

*(This page was intentionally left blank)*



# ROOF VENTING

## ROOF SAFETY

### LADDERS

- Secure the ladder where it meets the roof with rope or wire to keep it from moving side to side
- Extend the ladder 3' above the roof line
- Always set up the ladder on even ground
- Always have somebody holding the ladder when in use
- 4' to 1' ratio—the ladder should be 1' out from the wall for every 4' of height

### HARDHATS

- Anybody working on the ground under a roofing project should be wearing a hardhat

### ROOF JACKS

- Roof jacks are REQUIRED on all roofing jobs
- Roof jacks should be installed at the base of the roof, secured by nails when attached to decking, and screws when attached to furring strips through the tin
- Three roof jacks per board is ideal
- One nail can go into the hole that sticks up into the edge of the board to keep it from sliding

### DANGEROUS CONDITIONS

- Wet roofs are very dangerous, do not go up a wet roof
- Sunny days create dangerous heat and sun glare on metal roofs, encourage more breaks on hot sunny days
- Dewy mornings sometimes leave a small amount of water on the roof—do not go onto a wet roof, or out to work on a roof early in the morning
- Sawdust can become very slippery on a roof, NEVER make cuts on the roof, cut material on the ground, and pass it up to the roof

### FALLING OFF/FALLING THROUGH

- Particularly dangerous areas of the roof should be marked
- Edges can be marked with small strips of wood with caution tape tied to them
- Weak areas that a person may go through the roof can be painted with bright colored paint
- Ceiling joists should not be a walking surface, slide additional boards in to stand on, and tack them in place if you need to stand in the attic

### BATS

- If bats are present, or evidence of bats is present, do NOT work on the roof

### POWER TOOLS

- A large variety of power tools will be used at various points while working on roofs
- Create a good, safe cutting station on the ground, in a place where materials can be most easily transported up and down the roof

## **ROOF VENTING**

Roof venting is an important part of the roof system that is often overlooked. It allows hot air to escape from the attic space, cooling a house down significantly in the summer and reducing moisture build up during the cooler months.

Venting uses intake and exhaust vents to allow air to pass through the attic space. Properly constructed and sized venting is crucial to the performance of the building envelope. Hip roofs require vented ridge caps.

Spread the venting out evenly; it will not function properly if clustered on one part of the roof.

## **INTAKE VENTS**

Intake vents allow air to flow into the attic space.

- Soffit Vents: placed or built into the soffit, allowing air to flow through the underside of the eaves.
- Gable vents: placed on the gable ends of the roof, in pairs, allowing air to enter the attic space.

## *SOFFIT VENTS*

There are several different kinds of soffit venting. ASP uses vinyl soffits and screened vents.

### *VINYL SOFFIT VENTS*

Vinyl soffit allows for the greatest amount of air flow through the roof, and can be installed easily.

1. Install F-channel along wall, the bottom of the F level with the bottom of the fascia. Nail or screw into house. At the end of the eave, fold the F-channel up so that it runs vertically up to the roof. This will make closing the corners very easy.
2. Measure from the trough of the F-channel out to the outside edge of the sub-fascia. Cut a piece of vinyl soffit  $\frac{1}{4}$ " shorter than this.
3. Insert one end of the soffit into the F-channel, bending it up to run vertically at the corner, and screw the other end into the bottom of the sub-fascia. Put the screw through the channel in the soffit.
4. Cut the next piece of soffit, and snap into the first piece. Continue inserting into the F-channel, and screwing every other channel into the sub-fascia.
5. On the rake edge, run the F-channel all the way down to the eave, and begin soffit at this low corner. This will box in the corner. When complete, the fascia will cover the screwed part of the soffit.

air flow through the  
attic space

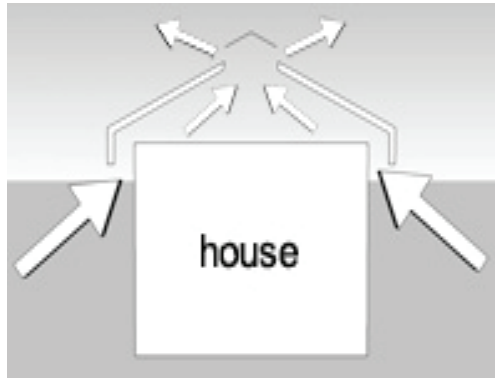

fascia

F-channel

vented soffit

small screw

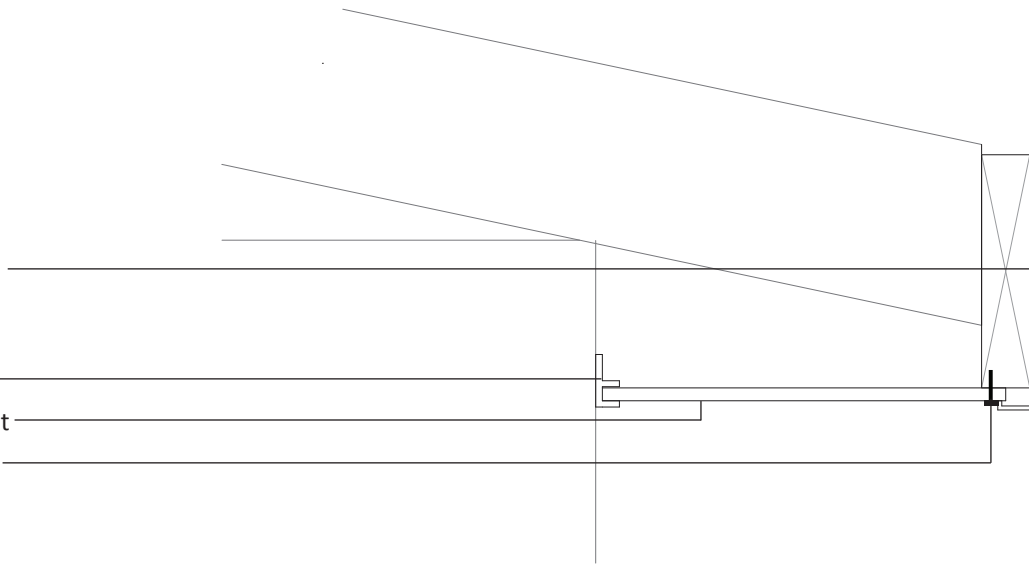

### *SCREENED VENTS*

If an unvented wood soffit is already present, screened soffit vents can be installed to allow for air flow. It is important to note that when using soffit venting, insulation in the attic space can get in the way of the venting. To prevent this, install baffles attached to the underside of the roof decking to create air flow channels. Baffles are usually Styrofoam channels that can be stapled to the decking, and extend about 3' up from the vents into the attic space.

1. Mark the wood soffit with the rectangles to be cut out for vent installation.
2. Use a jig/reciprocating saw to cut out the hole.
3. Screw in the screened soffit vent.

### *GABLE VENTS*

Gable vents are attached to the gable ends of the house, typically as 12" to 18" rectangular screened vents. Gable vents should always be used in pairs; this means placing them opposite each other on the gable ends. They are best used in combination with soffit vents, as they do not always allow for complete air circulation.

1. Mark the space to be cut out for the gable vent.
2. Cut the hole for the vent.
3. Install the vent, caulking around the opening before screwing the vent into place.

### **EXHAUST VENTS**

There are 3 main types of exhaust vents:

- Ridge vent: vent on the peak of a roofline and allows hot air to escape from the highest point in the attic.
- Mushroom vent: a static vent attached to the decking of the roof that allows air to escape the attic, while protecting the opening with a cap.
- Whirlybird: a turbine attached to the decking of the roof that uses the wind to spin it and pull hot air out of the attic.

### *RIDGE VENTS*

Ridge vents allow air to escape the peak of the roof, but also allow some moisture penetration if the storm has high wind associated with it. Ridge vents are required when installing roofing on a hip roof.

1. To install a ridge vent, cut a 1.5" space along either side of the ridge of the roof. Leave the last 24" of the ridge near the gables unexposed, as they will allow moisture in. Snap a chalk line to ensure a straight cut, and use a circular saw set to the depth of the decking to cut the space.
2. Purchase the ridge cap and vented closure strips from the metal roof manufacturer. Vented closure strips are required. If installing on a shingled roof, purchase ridge cap at the hardware store and follow included directions.
3. Screw the ridge cap into place, making sure that all spaces are covered and that you use the vented closure strips under the ridge cap. Use neoprene screws.

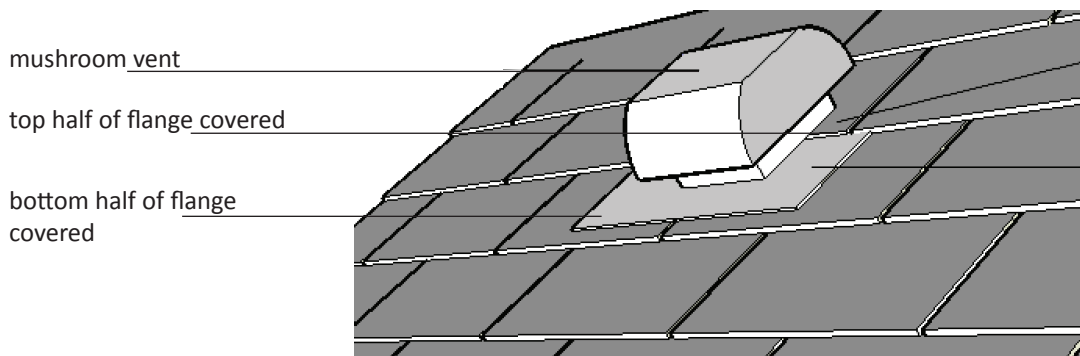
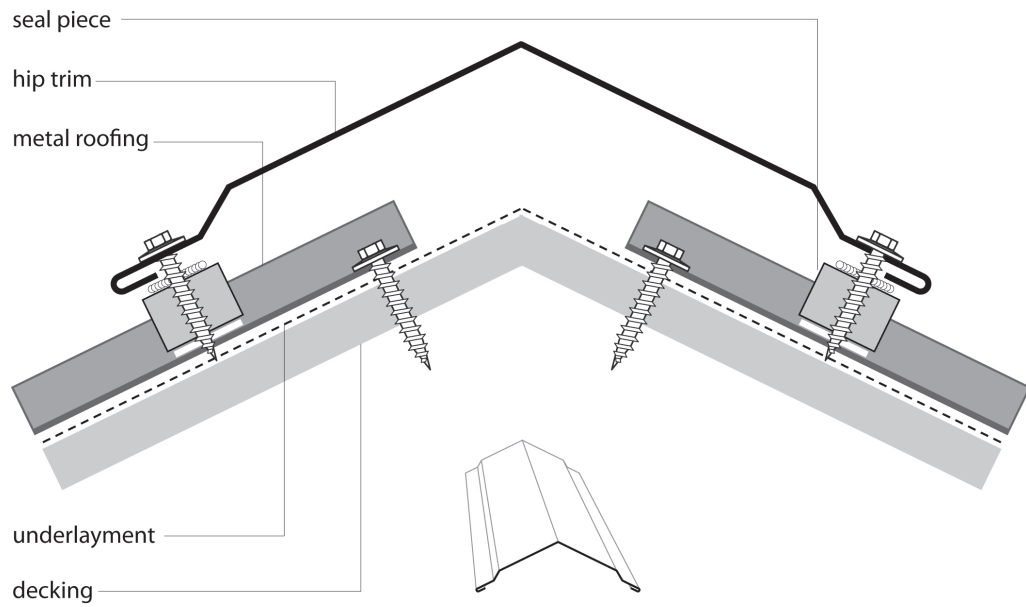
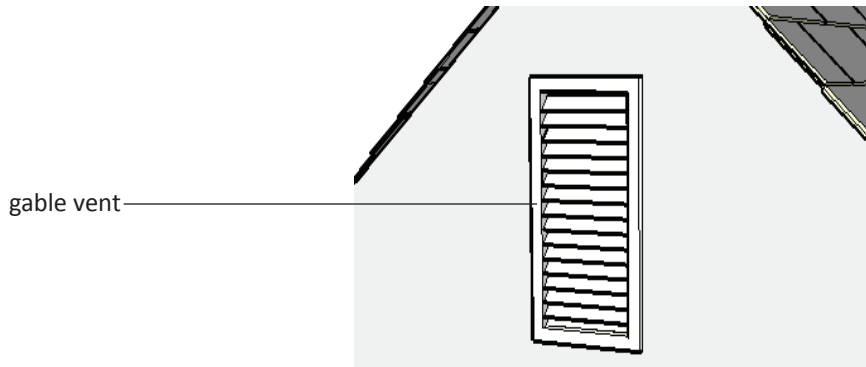

### *MUSHROOM VENTS*

1. To install a mushroom vent, cut a hole in the decking approximately the same size as the hole in the vent (***not the size of the flange, but of the vent!***).
2. Attach the vent to the decking with roofing nails, applying a caulk or roof tar under the around the underside of the flange. The flange should go on top of the lower shingles, and be covered by the upper shingles. Do not nail through shingles.

### *WHIRLYBIRDS*

These are not commonly used in new construction, and are included here only in the case that you run into existing ones. They only allow for less than 1 sq ft of venting.

Install in a similar manner to mushroom vents, following all manufacturers' recommendations.

# SIDING

## SAFETY

### LADDERS

- Secure the ladder where it meets the roof with rope or wire to keep it from moving side to side
- Extend the ladder 3' above the roof line
- Always set up the ladder on even ground (*use a shovel to level the ground—not blocks of wood under one leg of the ladder*)
- Always have somebody holding the ladder when in use
- 4' to 1' ratio—the ladder should be 1' out from the wall for every 4' of height
- If using a step ladder, **never** stand on the top two rungs

### HARDHATS

- If someone is working on a ladder, anyone nearby on the ground should be wearing a hardhat (to include the person holding the ladder)

### CUTTING SIDING

- Use only appropriate tools for cutting siding—tin snips are the safest

## SIDING

Siding is the outer protective layer of a home. It protects the framing, insulation, and interior of the home from the elements. Siding is added after the wall structure is completed, and is usually not a structural member of the house. However, in older construction, you may run across box-framing, which utilizes the siding as structural support. If working on a box-framed home, use caution. ASP predominately uses vinyl siding because of the ease of installation, cost, low-maintenance and sustainability.

The 4 types of siding:

- Board and Batten: utilizes rough cut lumber to cover the exterior of the home. It is usually low cost, but requires a long time to install properly and is high-maintenance.
- T1-11: a special plywood that covers the exterior of the home. It is high cost, requires a lot of primer/paint, and requires long-term maintenance.
- Vinyl Siding: a plastic product that snaps together. It can be installed quickly, and provides a very low-maintenance exterior.
- Lap Siding: uses wood or fiberboard planks that overlap horizontally to cover the home. It is typically used only in repairing existing lap siding. It requires painting.

### *GENERAL RULES FOR SIDING*

1. Underpinning should be installed before siding the house, as siding should overlap the underpinning by 1”.
2. Do not install siding closer than 6” to the ground if possible. If you have to, then use vinyl siding or install galvanized flashing that runs up behind the siding at least 12” high.

### *HOUSE WRAP*

House wrap provides a breathable waterproof barrier between the exterior of the home and the interior. Install prior to windows and doors.

*Note: Hammer or slap staple guns work well for installing housewrap.*

1. Start at the bottom of the house, rolling the house wrap around the exterior and over the sheathing. Attach with staples or roofing nails, *do not use button cap nails*. Do not worry too much about a nailing pattern; you are simply trying to get the house wrap snug and in position.
2. Roll across window and door openings; these will be cut and opened up later.
3. Do not use felt paper; only use actual house wrap, as it is the only product that actually works properly.
4. Overlap seams by 4”. Staple thoroughly on seams—this eliminates the need for tape.



board and batten siding

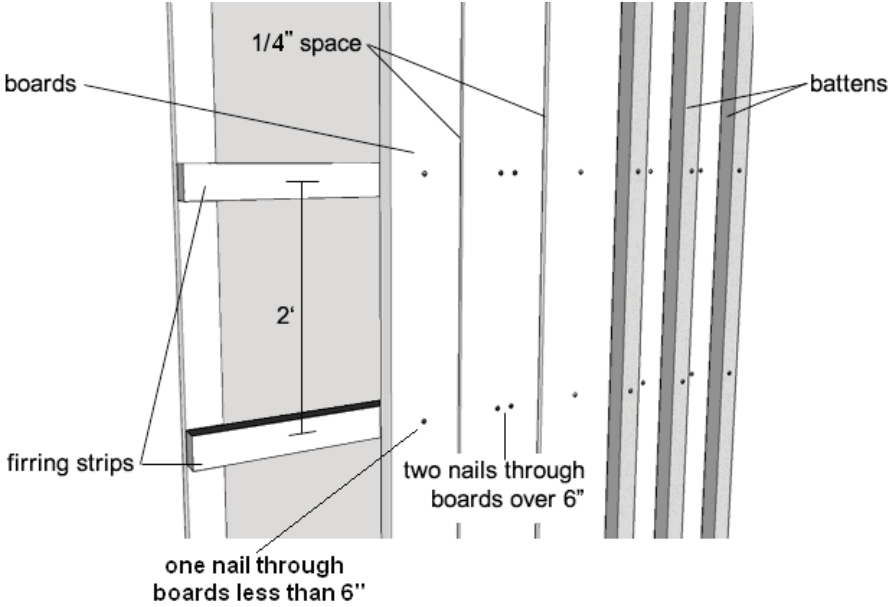

board and batten seams

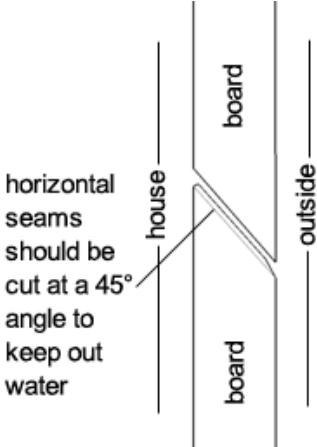

## BOARD & BATTEN SIDING

### *FURRING STRIPS*

Before beginning the actual siding, you must install furring strips; 1x4s installed horizontally across the home every 24" up the wall.

1. Snap level chalk lines every 24" up the wall, beginning at the bottom and working your way up.
2. Nail the 1x4s into place using 12d nails to hold the weight of the siding. These furring strips are what you will nail the siding on to.

### *BOARD & BATTEN SIDING*

Now that the furring strips are installed, the boards can be installed. They should be no less than 4" wide, and should preferably be the same height as the wall to be covered.

1. Begin fastening the first board vertically to the furring strips, using at least an 8d galvanized nail. Check that the first board is plumb, as it will set off the rest of your boards.
  - If the boards are less than 6" wide, use a single nail in the middle of the board at each furring strip.
  - If greater than 6", use 2 nails centered about 3" apart from one another.
2. Leave a ¼" gap between each board; this will allow for expansion and contraction of the wood.
3. Once all of the boards on a single side are in place, install the battens. Battens should extend ¾" over each board, and be centered on the gap between the boards. Fasten to the furring strip, not the boards, with the galvanized nails.
4. If your boards or battens do not extend the entire height of the wall you are covering, use a beveled end to join two boards or battens together.
5. Once the battens are completed, trim the corners with battens. Use a butt joint to overlap the joint of the siding.
6. Trim around windows and doors. This can be challenging, as every window is framed out differently, and then everyone tends to trim a bit differently. A good solution follows:
  - Before installing the boards, remove any existing window trim.
  - Rip battens to a width that will put them flush to the surface of the boards. Rip one a ½" wider for the bottom of the trim. Cut the header trim so that it will run across the tops of the side trim, and do the same for the bottom trim.
  - Install with galvanized nails around the window, and then install the furring strips and boards.
  - Install window/door drip cap or z flashing above windows/doors.
  - Once the boards are complete, use 1x4s or battens to trim out the top and sides of the window. The bottom will have a slight overhang that you created. Caulk all surface seams well with silicone caulk.

## Z flashing

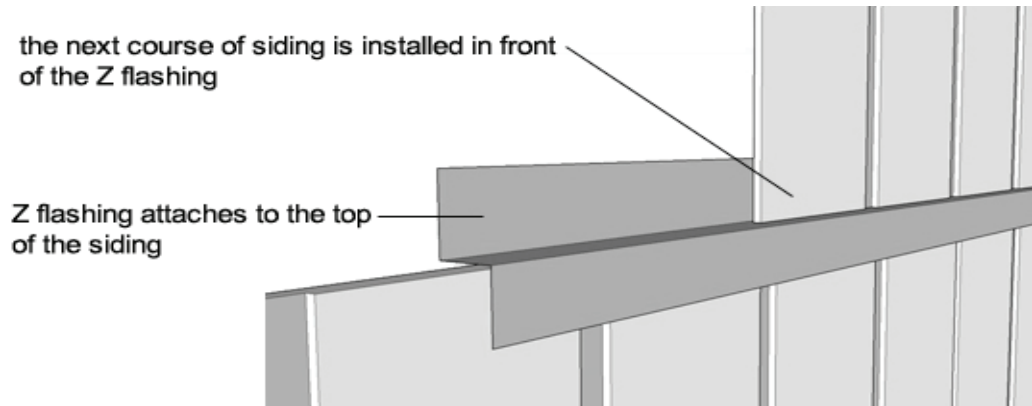

## finishing corners

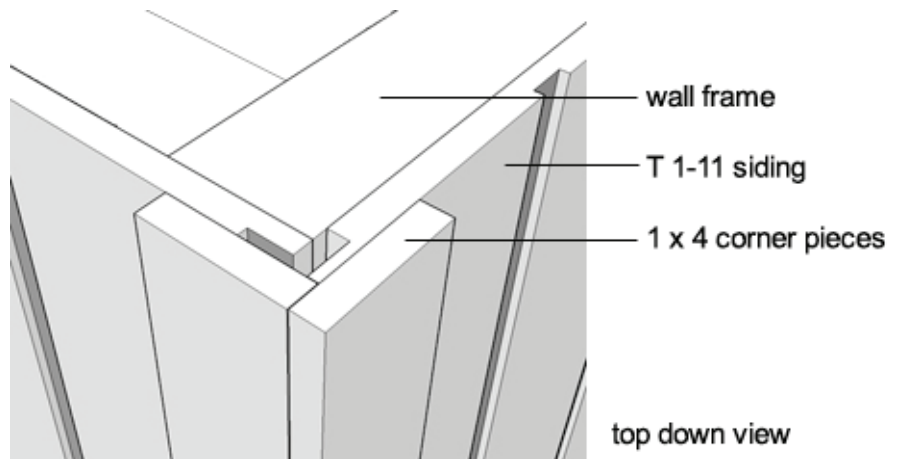

## T1-11 SIDING

*This is to be used only when repairing existing T1-11 siding.*

1. 5/8" T1-11 can act as a structural siding, and can be applied directly to the studs without sheathing.
2. **Prime both sides of the T1-11 before installing.** You can also apply a layer of paint before installation as well. Note that it will take several coats before it fully covers.
3. Fasten T1-11 with 8d galvanized nails every 6" around the perimeter and 12" along the studs.
4. All sides of the T1-11 should meet on a stud. The tongue and groove should overlap, leaving 1/8" space for expansion/contraction.
5. When a single sheet will not cover the entire height of the wall, use z-flashing in between the two pieces.
6. Trim the T1-11 in a similar manner to the board & batten siding, using a butt joint on the corners, and painted 1x4s to trim around doors and windows. Attach with galvanized nails.

## VINYL SIDING

Sheathing (OSB, plywood, or solid foam insulation board) must be used behind vinyl siding.

**VINYL SIDING IS ATTACHED WITH ROOFING NAILS. IT IS CRUCIAL TO LEAVE NAILS 1/16" OUT FROM VINYL (OR A DIME'S WIDTH). THIS ALLOWS THE VINYL TO MOVE AS IT EXPANDS AND CONTRACTS.**

1. Install the J channel along the bottom of the wall. All this is to hang down 1" past the sheathing.
  - Snap a chalk line across the wall to make sure that the J-channel will stay level. This is very important. If it is not possible to stay level (the wall makes a sudden drop down) consider stepping down the siding at this drop. We use J-channel at the bottom because we find that using a starter strip often leads to the bottom row of vinyl becoming unlocked. With J-channel vinyl will always stay in place.
  - Align the top of your J channel with the chalk line, and fasten either end of the strip with roofing nails to the wall. Fill in every fourth hole with a nail, leaving it a slight bit loose.
  - Check again for level. Continue installing J-channel on bottom of wall. Butt together each J channel and drill 1/4" holes in the bottom of the J every 4' to act as weep holes to allow moisture to escape.
2. Trim the corners of the house with vinyl corner pieces, available as outside and inside corners. Make sure to take into consideration that they are different pieces. Install with roofing nails.

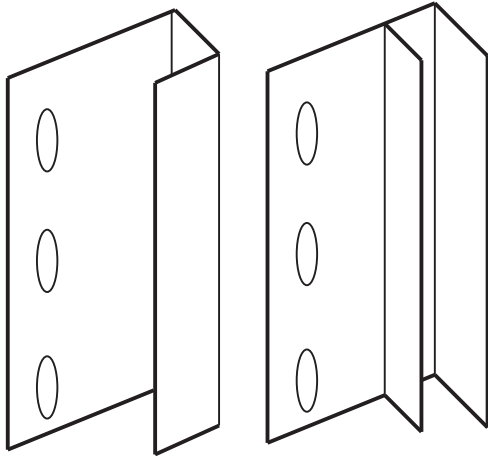

J-channel

F-channel

J Channel lines the top and sides of any window or door

top piece cut to drain water into sides

slots for nails

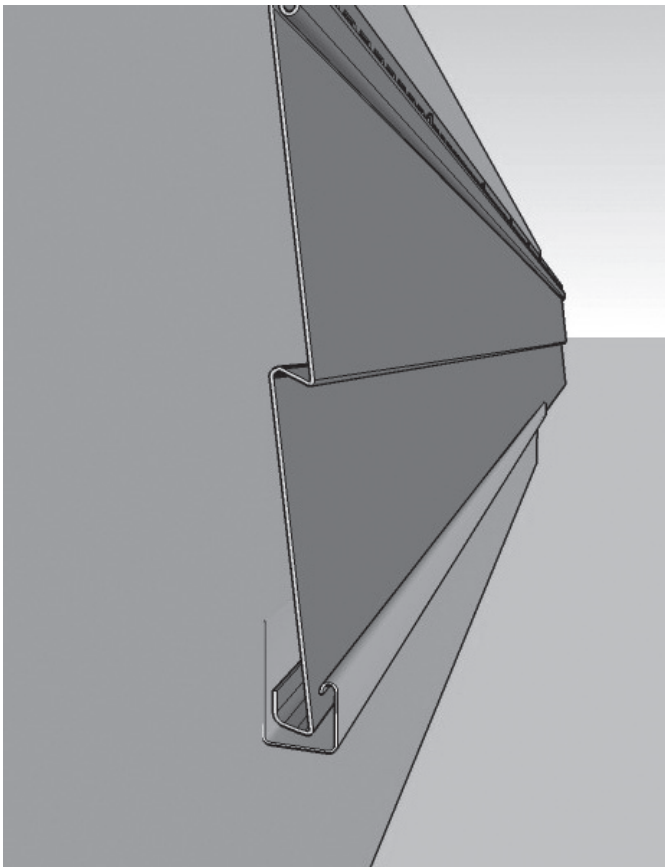
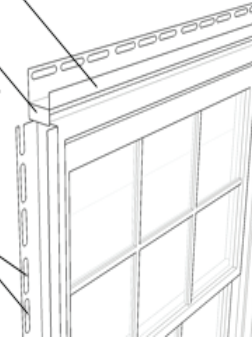

nail in the center of the slot



minimum 1" overlap

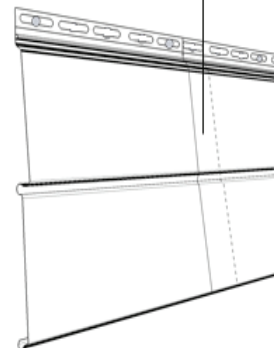

### 3. IF SOFFIT IS TO BE INSTALLED WITH SIDING

- Continue installing vinyl siding up past the level of the sub-fascia. This last row of vinyl will have F-channel or J-channel attached over top of it to accept soffit. If nail flange must be trimmed off to allow course to fit, it will be held in place by J-channel or F-channel.

#### IF EXISTING SOFFIT IS TO REMAIN

- Trim the top of the wall with J-channel. This should cup down to hold the top of the vinyl siding. Make sure that it is flush with any existing soffit. Attach with roofing nails and fill every 3rd-4th hole, checking for level as you go.

### 4. Trim around doors and windows using J-channel

- Begin by cutting the side pieces of J-channel, bringing it flush with the top of the window or window trim. It should extend approximately 1" below the bottom of the window/trim. Install with J facing out.
- Cut the top piece of J-channel to extend to the outsides of the side J-channel. Cut a tab out of the bottom of the channel and fold it down into the side channels to allow for water run off.
- Use finishing trim/undersill trim along the bottom of the window. It should fit in between the two side channels, and cup downwards.
- You must use snaplock punch for vinyl to lock into undersill trim.

### 5. Begin installing the vinyl siding. Install each panel "loosely" to allow for expansion and contraction.

### 6. The first piece should be installed on the side that receives the least amount of wind.

- Click it into place under the starter strip, and gently pull up on it.
- Attach every 4-6" in the middle of the slots with roofing nails, keeping the nail head 1/16" from the vinyl. Never use staples.
- Overlap the next piece by 1", and continue nailing through the slots.
- Work your way up the house, using tin snips to make any necessary cuts. Make sure that factory edges overlap, not hand cut ones.

### 7. When you reach a horizontal channel (under a window, over a door, at the top of the wall) make sure to get the vinyl snugly tucked in there. It may take some careful measurement and cutting, but you do not want any edges to be visible outside of the channels.

### 8. Do not use pieces of siding less than 2' in length.

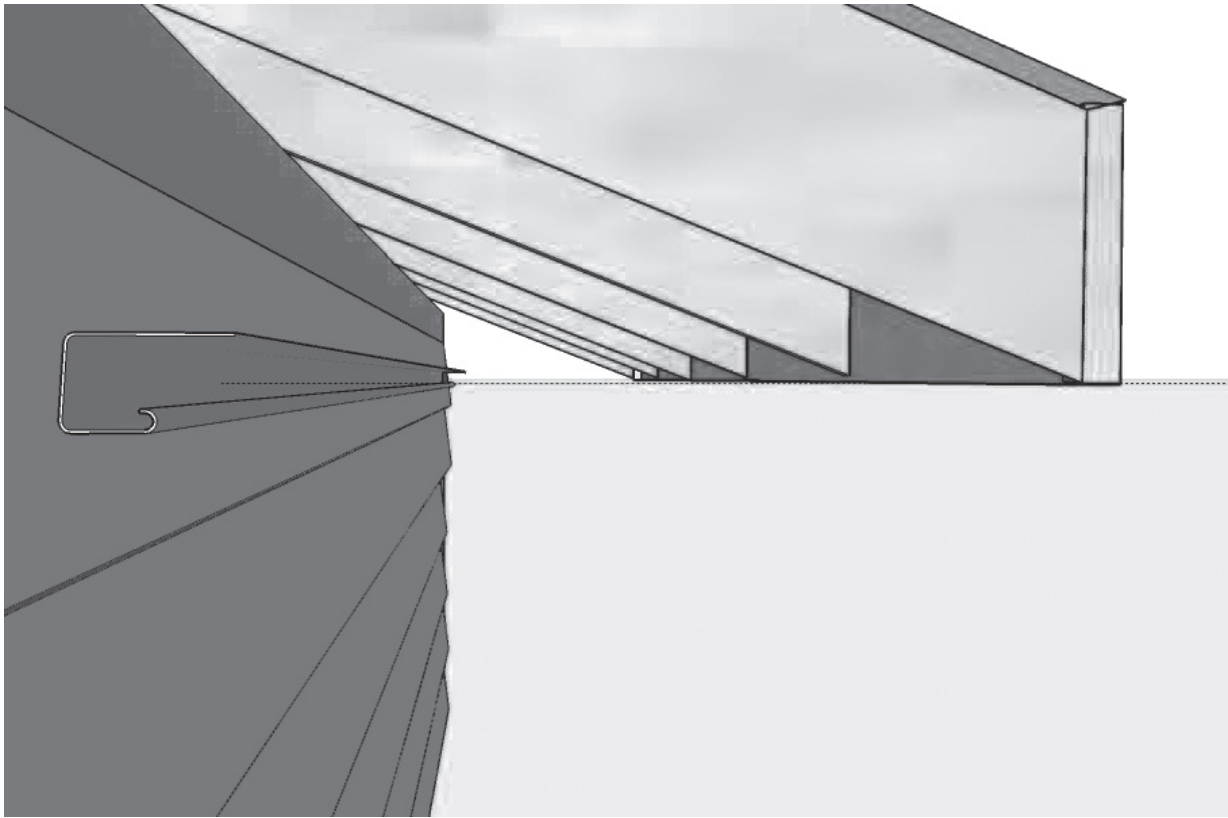

## LAP SIDING

*This method of siding should only be used to repair existing siding.* Lap siding is made with masonite, wood, cement board or some kind of wood composite material. The planks are available in widths from 4"-12". This siding method requires sheathing.

1. It is important to get the first piece level and square. Install a 1" starter strip, ripped from a full board or purchased separately, and attach to the sheathing/studs using 8d nails every 12". This will get the entire siding process going correctly.
2. Install vertical strips at the corners that correspond to the overall thickness of the lapped siding. This will make trimming the corners easier.
3. Begin installing the siding so that it overlaps the 1" starter piece and butts up to the vertical strip. Make sure it's level, and attach with 8d spiral galvanized nails every 12" along the top. Make sure not to overdrive the nails, and try to nail through the studs, not just the sheathing.
4. Build 2 identical jigs out of scraps to ensure that each lap will be identical. The jigs can be simple T's, but will help to keep the siding level and looking good.
5. All seams must end on a stud, and staggered by at least 1 stud distance. When meeting mid-wall, make sure that the butting seams are factory edges, and are separated by 1/8".
6. Caulk all vertical seams with paintable exterior caulk.
7. Trim out windows, doors, and corners in a similar fashion to how you would with board & batten siding (see BOARD & BATTEN).

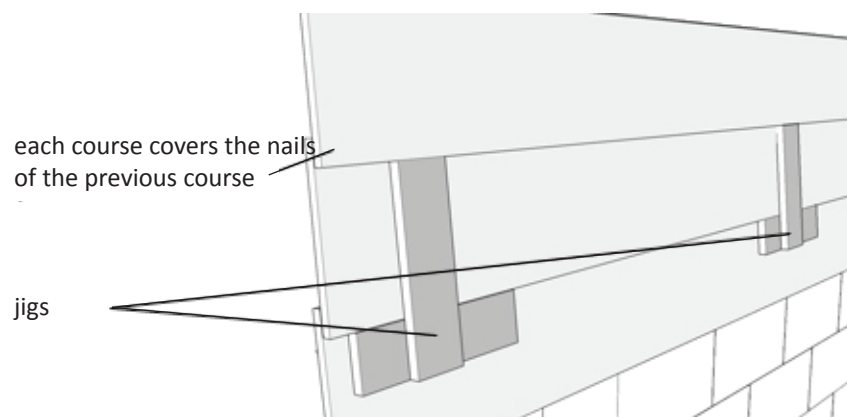
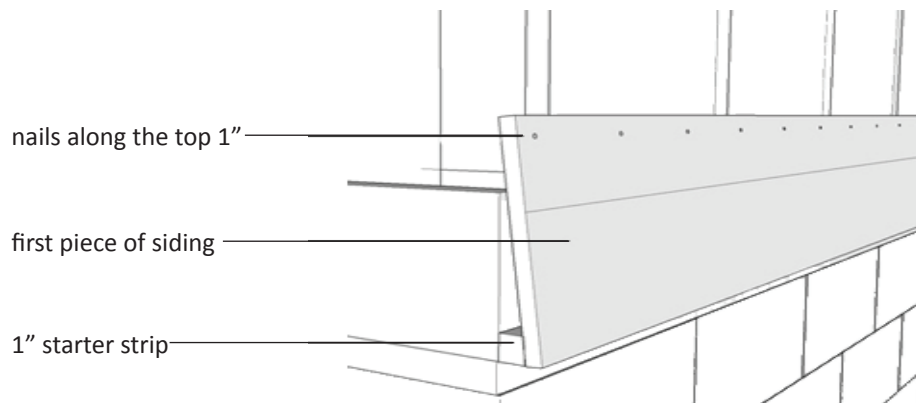



## AIR SEALING & INSULATION

### **SAFETY**

- While working with insulation, always wear gloves, goggles, face masks, and long sleeve shirts.
- If you get insulation on you, take a cold shower to close your pores as soon as you can.
- Always place old insulation into trashbags.

## **AIR SEALING & INSULATION**

Air sealing is the process of reducing drafts and heat loss by creating a continuous envelope around the house.

Insulation is a thermal barrier that resists the flow of heat between the interior and exterior of a home. For it to properly function, insulation must be installed correctly and in conjunction with air sealing.

### **AIR SEALING**

An air tight envelope around the home is an important step in creating a comfortable living space. The process is simple and results in significant savings for the families we serve. More than 30% of home heating and cooling costs are associated with the movement of air between the interior and exterior of the home.

When a wall is accessible, you should make sure that at least one side has an air seal. There are several different methods that can be employed to seal the wall.

- Rigid foam insulation: foam board (blue, pink, or white) that can be nailed to the exterior wall and then sealed with tape, mastic or caulk.
- OSB sheathing: the seams here also need to be sealed with mastic or caulk
- Drywall: so long as all penetrations are sealed to the drywall with tape or caulk

Any loose-fill insulation, such as fiberglass or cellulose, needs to be air sealed on either side. The movement of air through the insulation can cause dramatic heat/cooling losses. This is as simple as sealing the drywall on the interior of the home, and sealing the OSB sheathing on the exterior. No vapor barrier should be installed, as this will actually trap moisture in the insulation and cause damage in the future. Correctly sealing the foam board, sheathing, and drywall should be sufficient enough to prevent air flow. This includes plugging any holes or gaps with caulk.

### **INSULATION**

There are 3 common types of insulation:

- Fiberglass batts: lengths of insulation that is the easiest to install. It comes sized for 16" or 24" on center framing, and is available in many different thicknesses and R-Values.
- Cellulose insulation: this is commonly called blown insulation. It is blown into place using a mechanical blower, and is made of recycled materials that fill in a space. It is best used in attics, and has the highest R-value per inch of thickness
- Polystyrene (foam) insulation: typically made of Styrofoam. It is best used in full sheets or in areas where the insulation might encounter moisture.

### *R-VALUES OF INSULATION*

Every form of insulation has an R-value. This stands for the resistance value of the material, or the ability of the material to resist the flow of heat. The higher the R-value, the better the insulator.

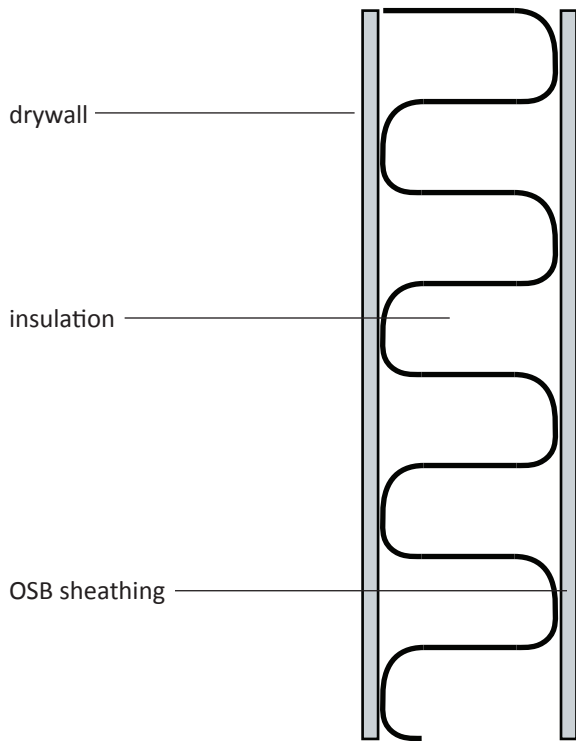

Typical requirements for R-values are:

|                     |      |
|---------------------|------|
| Floors              | R-19 |
| Walls               | R-13 |
| Behind tubs/showers | R-15 |
| Pitched ceilings    | R-30 |
| Flat ceilings       | R-38 |

Fiberglass insulation comes in different thicknesses, which correspond to different R-values. The thicker the insulation, the higher the R-value

| R-Value | Thickness |
|---------|-----------|
| R-11    | 3.5"      |
| R-13    | 3.5"      |
| R-15    | 3.5"      |
| R-19    | 5.5"      |
| R-21    | 5.5"      |
| R-30    | 8.5"      |
| R-38    | 12"       |

Though rarely thought of, all materials have some sort of R-value. They are not really considered in home construction, but here are a few common building materials

| Item             | Thickness | R-Value |
|------------------|-----------|---------|
| Drywall          | .5"       | .45     |
| Plywood          | .5"       | .65     |
| Concrete block   | 8"        | 1.1     |
| Asphalt shingles | .125"     | .15     |

## FIBERGLASS INSULATION

It is important to wear gloves, long sleeve shirts, pants, and dust masks when working with fiberglass insulation. It can cause irritation, itching, and should not be inhaled. Take a cold shower after working with insulation to close your pores and allow insulation to wash off. Hot water makes your skin even more irritated.

Do not get fiberglass insulation wet, as it decreases the R-value and thus the effectiveness of the material. If the fiberglass insulation should get wet, dry it out before installation. ***NEVER install wet fiberglass insulation.***

Fiberglass insulation can be purchased either faced or unfaced. The facing is made of paper, and should be installed so that the "Paper is to the People". This means the facing should be towards the interior, the unfaced side towards the exterior.

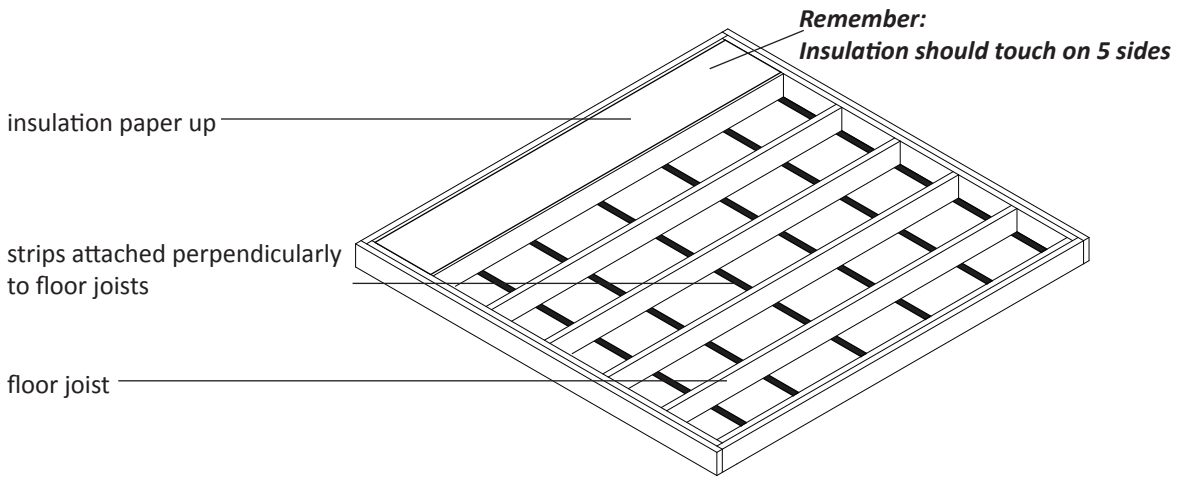
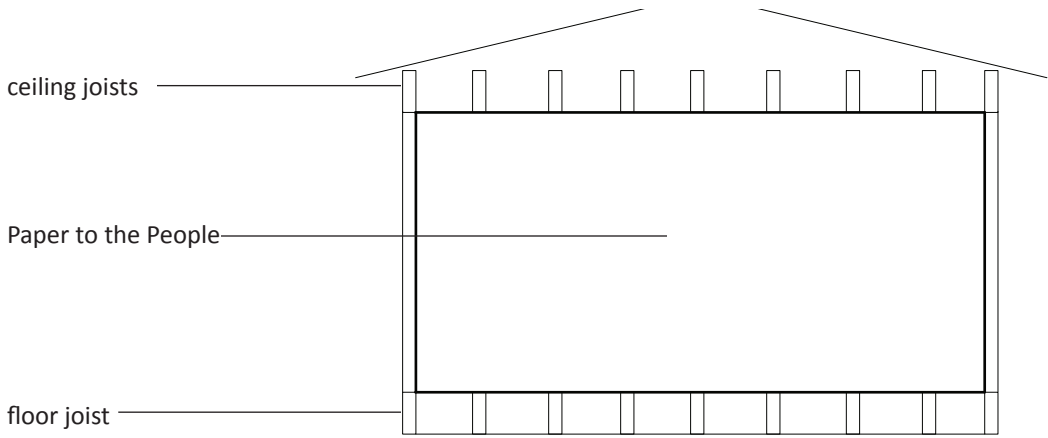
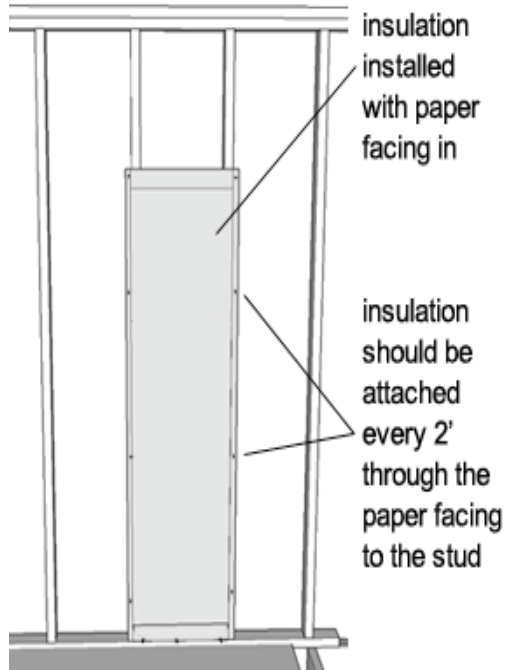

## **INSULATION SHOULD TOUCH ON 5 SIDES**

***When installing insulation it is important to keep in mind that it should touch the framing/drywall/osb on 5 sides. For example, if insulating a floor it should touch the joists on both sides, it should touch the band joists on both sides, and it should touch the subfloor above the insulation. When insulation touches on 5 sides it ensures that the thermal barrier surrounds the entire living space, leaving no air gaps. This is critical to maintain the R-value of the insulation and to provide the most effective insulating properties.***

To install faced insulation, unfold the tabs on either side of the paper. Use these to staple the insulation to the face of the framing members, placing a staple every 18-24". Take care where two pieces of insulation meet, as well as the top and bottom plates of the wall. There should not be any gap, as this will allow air to pass inside and out. If need be, you can use tape to make sure that everything is sealed well. Around electrical boxes and openings, cut a hole in the insulation, making sure that it will fit tightly around the obstruction. Take care not to compress the fiberglass, as this also reduces the R-value.

Unfaced insulation can be used under floors and in attic space. In the attic, it can be laid into place if the ceiling is in place. If there is not drywall on the ceiling yet, you can use drywall tape to temporarily keep it in place. Staple it across the ceiling joists every 24" and slide the insulation above the tape. Take care not to allow any gaps between the joists and the insulation. Around any heat producing obstruction, leave a 3" gap.

For under floors, you will need to use chicken wire, house wrap, or mesh to keep the insulation up and in place between the floor joists. Cut the holding material into wide strips, and staple perpendicularly to the joists. Lightning rods, thin metal sticks, can be used, but they tend to fall out of place after a couple of years, allowing the insulation to sag and fall from underneath the floor.

To cut fiber glass, use a 2x4 and exacto knife. Lay the 2x4 across the insulation, and use it as a straight edge to cut across the insulation, making sure not to compress the insulation for too long.

## **CELLULOSE INSULATION**

Cellulose has a higher R-value than fiberglass, and thus is good for attic space. It can be blown to any desired R-value, as it simply piles up. Rent a blower unit and follow directions that come with it.

***NOTE: It is important to wear a mask with blown insulation.***

For attic spaces, cover the entire area evenly with the manufacturer's recommended amount of cellulose to achieve the desired R-value. Allow a 3" clearance around heat producing obstructions. Also keep in mind the venting that may be in place, and keep the insulation out of the way of air flow. If need be, install baffles to maintain air flow (see VENTING).

## **FOAM INSULATION**

Rigid foam insulation typically comes in 4'x8' sheets in varying thicknesses. Rigid foam should only be used in instances where moisture may cause a problem. Try to install in full sheets where possible, creating the fewest amount of seams. Every seam should be sealed with mastic or special tape to prevent air infiltration.

# DRYWALL

## SAFETY

### *LEAD PAINT*

- Lead paint can be present on almost any home, and it is always best to assume that paint is lead based
- Avoid dry scraping paint as much as possible
- Never sand a painted surface, or use a heat gun to remove paint
- Always wear an appropriate mask when working with or removing any material with loose paint

### *KICKERS*

- Kickers should be put in place any time you are removing any sort of support from a wall, or underneath a wall. Movement that could result from a lack of sufficient temporary support can create dangerous situations

### *DRYWALL*

- Always wear a dust mask when sanding drywall mud
- When cutting drywall with utility blades, make sure the work area is being kept safe—i.e., materials are well-secured when cutting, blades are closed or covered when not in use, and the area is well-lit and free of excessive dust and clutter
- Hardhats should be worn anytime tools are being used overhead, working on ceilings, or working on walls from a ladder

## **DRYWALL**

Drywall comes in sheets, either 4'x8' or 4'x12', ranging in thickness from 1/4" to 5/8".

The finished side of drywall is smooth and dull white or green and should face into the room. The back is made of paper.

"Green board" is a moisture resistant drywall used in any place where moisture may be a problem. It is either green or blue.

### *TOOLS AND MATERIAL CARE*

Before discussing how to drywall, it is important to understand the importance of keeping your tools and materials clean, neat, and organized.

1. Never leave drywall/corner bead someplace where it may collect moisture, or where it could possibly get broken. If the drywall is compromised, it is worth purchasing new drywall.
2. Clean your tools after you are finished using them. This may be in the middle of the day, but you will thank yourself later, and you will get a more professional looking product this way.
  - Scrape all mud out of mud trays into the trash, not back into the bucket or onto the ground.
  - Clean the trays and drywall knives with soap and water, making sure that they are completely clean.
  - Dry your tools off; otherwise they will rust and discolor the compound mixture.
3. Mix the drywall compound anew at the start of each day, and clean the mixer paddle off. Add clean water to the mix as well in small amount to produce a smooth mixture. The mixture should have the texture of mayonnaise.

### *PRIOR TO HANGING DRYWALL*

Confirm that the following are complete:

- All inspections: Inspectors need to see the framing, insulation, plumbing, and wiring before drywall work begins. If not seen, the inspector will require the drywall to be removed, undoing all of your hard work.
- All wiring and plumbing: All wiring and plumbing must be completed before drywall is begun, or else holes will need to be cut in the drywall to proceed.
- Nailers are installed: Every edge and corner of the drywall needs to land on a piece of lumber. Do a scan and determine whether or not you will need to install nailers, which are simply lumber used to support edges of drywall.



*(This page was intentionally left blank)*

## **CUTTING DRYWALL**

To cut drywall, use a utility knife and a large straight edge.

1. Measure the size of drywall that you need. You should always use full sheets when possible.
2. Using the utility knife and straight edge, score the finished side (front) of the drywall.
3. The drywall should snap easily if you bend it back away from the scored side.
4. Slice the paper with the utility knife along the break.
5. Mark and cut holes for electrical boxes or plumbing, using your utility knife or a key hole saw.
6. If the piece is a bit too long, you can use a rasp to shave down the edge. If cutting into existing drywall, be careful of plumbing and wiring.

## **HANGING DRYWALL**

Factory edge should meet factory edge when hanging drywall.

1. Drywall can be hung horizontally or vertically. Horizontal installation requires less time on a ladder.
2. Hang ceiling drywall prior to hanging the walls.
3. When hanging drywall, you want the screw head to create a slight dimple, but not punch through the drywall. To accomplish this; practice and use a dimple bit. If you miss the stud/joist, simply remove the screw and mud over later. If the screw head breaks the drywall, leave it in place, and try a new screw a bit away from the broken space.

## **CEILING DRYWALL**

1. Use 1/2" drywall on the ceiling.
2. Build 2 T-braces to hold up the drywall while fastening to the ceiling joists. Use scrap 2x4s, or whatever you may have on site. It will be much easier than standing on your toes trying to get the drywall in place.
3. Begin in the corner of the room, preferably on a square wall. Hang the drywall perpendicular to the ceiling joists.
4. Fasten drywall with 1 5/8" coarse thread drywall screws. Fasten every 8" on ceilings. Make sure to butt edges together, especially the long horizontal seams.
5. Make sure to cut out for overhead light boxes, as they are very difficult to find afterwards.

nailing pattern

ceiling

wall

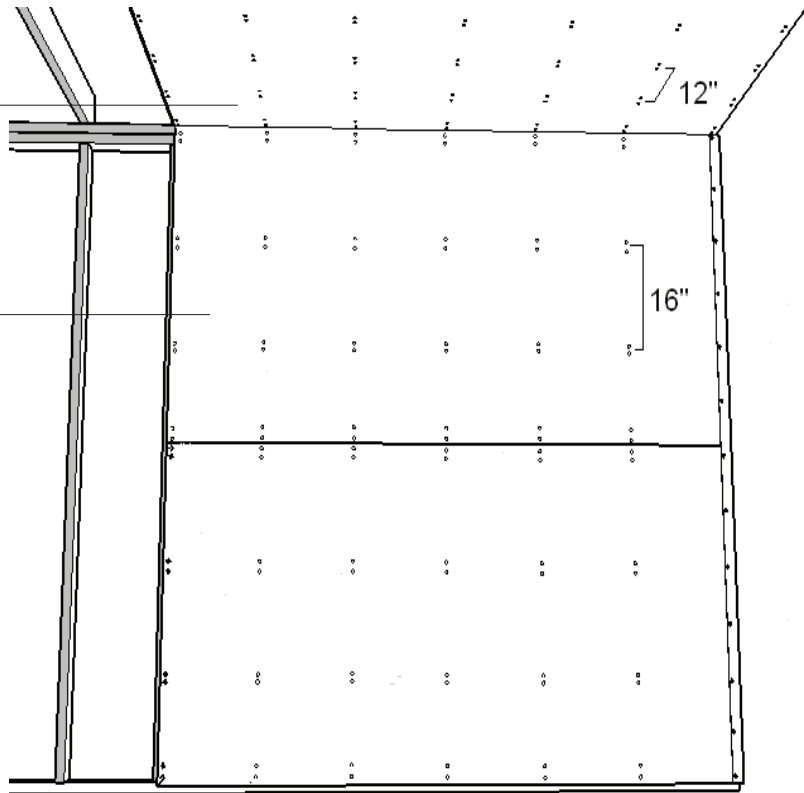

T-brace

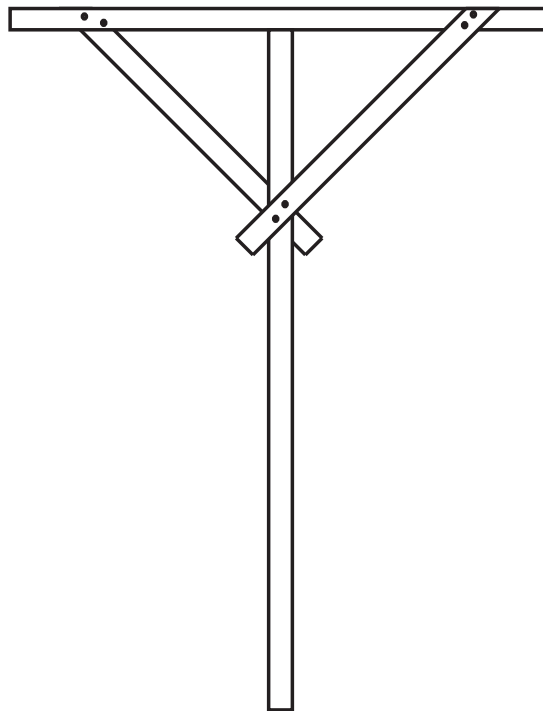

## WALL DRYWALL

1. Begin with the upper sheets first, and then the lower sheets.
2. Be sure that all vertical joints will land on a stud or a nailer, and factory edge meets factory edge.
3. Cut out any holes for plumbing or electrical boxes. Make sure to do this, because it is difficult to find afterwards. Use a T-square to mark and cut clean holes.
4. Leave at least a ½" space between the bottom of the drywall and the subfloor. Butt seams tightly together, especially the long horizontal edges. This makes taping and mudding much easier.
5. Fasten with 1 5/8" coarse thread drywall screws, screwing every 12" along the studs. If need be, use a T-square and mark the studs on the drywall.

## AIR SEALING DRYWALL

It is important to caulk all penetrations in the drywall. This includes, but is not limited to, windows, electric boxes, plumbing fixtures, light boxes, heat vents, etc. This will restrict air movement, helping to save the family money and keep warmer in the winter and cooler in the summer.

## CORNERS

Outside corners (any corner that protrudes into a room or hallway) need to have corner bead installed. Corner bead is a metal or vinyl strip installed on outside corners to protect the drywall from being damaged.

Attach corner bead using drywall nails. (*Screws generally hold out from the surface and make mudding harder.*) Be careful not to bend the corner bead, or else it will be impossible to correctly mud and finish. Place a nail every 4-6" to ensure that it is snug.

*Inside corners will be finished with paper drywall tape.*

## FINISHING DRYWALL

Finishing drywall is by far one of the more tedious and time consuming steps in the home building process. If at first frustrated, revisit the following directions and speak to a staff member or experienced volunteer.

Some tips:

- Light coats dry faster and finish better.
- Use a 6", then 10", and then 12" knife.
- Practice on scrap drywall before beginning on the actual walls and ceilings.
- Work with small amounts of mud, rather than huge globs in your tray. It quickly dries out, and gets heavy.
- Never replace mud into the mud bucket; throw it out, and clean your tools thoroughly and often.
- Place mud in a tray, and work it smooth in the tray with a knife before applying to the wall.
- Assign someone to check all screw heads prior to beginning taping. Take a putty knife and run it over each head; if it catches, sink it just a bit further. There should be a slight dimple in the drywall.
- Mix drywall mud with a small amount of water to get a "mayonnaise" consistency.

## TAPE COAT

1. Decide which tape you will use:
  - Paper tape: by far the most common, this tape must be embedded in drywall compound (mud) in order to properly adhere. It finishes more easily, and comes pre-creased for ease of use on inside corners.
  - Fiberglass/mesh tape: can be adhered directly to the drywall as it is slightly sticky. It cannot be used for inside corners.
2. Mix the drywall compound in the bucket, using a mixer attached to an electric drill. Add a slight bit of water, but do not over-mix the mud, as it will cause air bubbles.
3. Check closely after each coat, as mistakes are easier to catch and fix in between coats rather than at the very end.

### *TAPE COAT WITH PAPER TAPE*

1. Begin on the ceiling, applying a generous coat of mud along the seams using a 6" drywall knife. The trick is to start with the knife perpendicular to the drywall when full of mud, and flattening out as you use the mud. Also, knock the mud off of the corners of the knife to achieve a ridge-free coat.
2. Lay the tape over the mud, centered on the joints. Once in place, flatten with your knife starting in the center and working outwards. Clean your knife as you work, to keep from getting it loaded with dry mud that will cause streaks and ridges.
3. Use firm pressure to imbed the tape in the mud. You can always scrape off excess mud.
4. Allow the mud to dry.
5. Gently scrape the dried mud, smoothing it out some and knocking off any ridges/chunks. Spread a thin layer of mud over the seam, using a 10" knife. This is a skim coat.
6. If you notice a bubble in the tape, simply cut it out with an utility knife, and fill with mud. No need to re-tape.

### *TAPE COAT WITH FIBERGLASS/MESH TAPE*

1. Press the tape firmly into place along the seams of the drywall, centering it.
2. Apply a thin layer of mud on top of the tape with a 6" knife. You should still be able to see the tape through the mud.
3. Allow the mud to dry.
4. Gently scrape the dried mud, smoothing it out some and knocking off any ridges/chunks. Spread a thin layer of mud over the seam, using a 10" knife. This is a skim coat.

### *INSIDE CORNERS*

*Always use paper tape on inside corners.*

1. Apply a thin layer of mud to the corner as well as both sides.
2. Cut your tape to length, and gently crease. Usually there is a scored line in the middle of the tape to help.
3. Firmly press the tape into the corner, running a knife down each side to set it into the mud and working out excess.
4. Lightly coat both sides of the joint with mud.

### *OUTSIDE CORNERS*

1. Fill the corner bead with mud between the ridge on the corner and the edge of the drywall.
2. With mud on your 6" drywall knife, run the knife from top to bottom of the corner; the knife should be held at a 45 degree angle to the wall, touching the outside of the corner bead and the drywall.
3. Scrape off excess mud, and clean off any drywall compound left on the ridge.
4. There should be a 4" wide strip of mud on both sides of the corner.

### *FASTENER HEADS*

Each and every fastener head needs to be covered with mud.

1. Begin by covering all heads in a row at once, moving across the drywall in one stroke.
2. Knock off any excess mud with your knife.

### **SKIM COAT**

*Allow the tape coat to dry completely before even beginning the skim coat.*

1. Use a 10" knife for the skim coat. Slightly build up the center of each seam, and taper it out to the drywall. The skim coat should extend 2" to either side of the tape coat.
2. Make sure to knock off the corners of your knife before applying the coat, as this will allow for a much smoother coat.
3. The tape should no longer be visible after the skim coat. However, do not apply the mud too thick, or it will take forever to dry, and usually not look that great.
4. Apply a second coat to all fastener heads; they should not be visible after the skim coat.
5. Make sure to knock off any ridges or clumps that you may see, as these will need to be sanded out later anyway.

### *SKIM COATING CORNERS*

Apply the skim coat to inside corners with a corner knife, a special knife with a 90 degree angle so as to coat the entire corner in one stroke.

If a corner knife is unavailable, skim one side of the corner, allow to dry, and skim coat the other side.

### **FINISH COAT**

1. Allow the skim coat to completely dry. Scrape all joints, knocking down ridges and clumps.
2. For the finish coat, use a 12" drywall knife. Use the same method as before, only this time there will only be 1" on either side of the previous coat. This last coat should really have little shape to it, making it as flat as possible.

outside corner

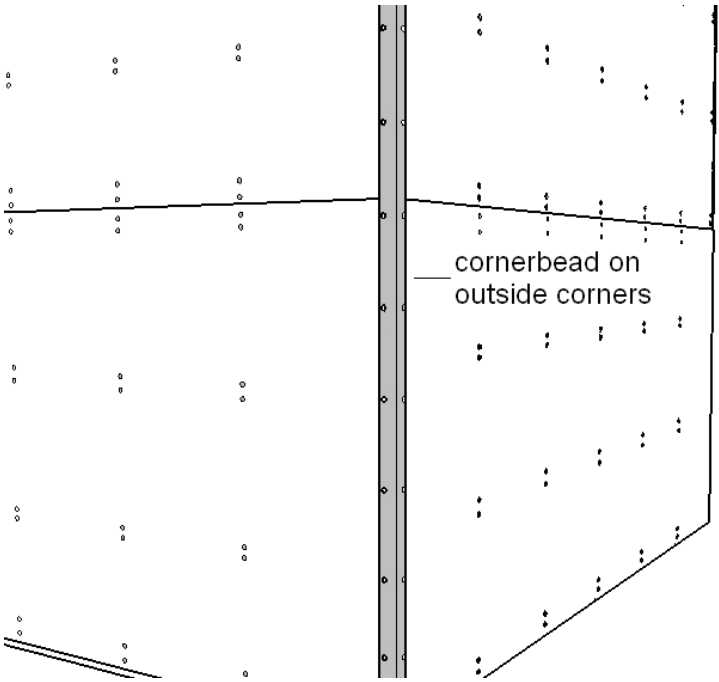

Layers of Drywall Mud



## SANDING

*Sand only after the final coat, as it is messy and creates a lot of dust. **Wear proper eye protection —preferably enclosed goggles—and an N-95 face mask to keep from inhaling the dust.***

1. Allow the finish coat to completely dry.
2. Using drywall sanding screens (100 grit), lightly sand the seams where there are high spots.
3. Where there are low spots, fill with mud. Do not sand the seam down to match the low spot.
4. Avoid over-sanding. This becomes very obvious when painting, and can also lead to seeing the tape as well as messing up the surface of the drywall, which you have worked so hard to make seamless and beautiful.

## TEXTURIZING

Adding texture to drywall is the best way to conceal any mistakes, as well as create an attractive final product. Again, drywalling is one of those very difficult and detail oriented tasks, and adding texture can help to take away some of the frustration.

1. Complete all tasks as if you were going to simply paint the smooth drywall.
2. Determine which surfaces you will add texture too. There are a variety of ways to add texture:
  - Nappy rollers, sponges, brushes: these are great ways to add texture by hand to a small space. They can be unique and special, but take a good deal of time. Prime, paint, and trim after allowing plenty of drying time.
  - Air pressured hopper – this is a quick and painless method if the hopper and air tank are available. Mix drywall and water to produce a mixture that is similar to pancake batter. It is sometimes better to spray on 2 light coats in place of one heavy coat, especially if you are inexperienced.
3. Discuss with the homeowner that they will have textured walls/ceilings and explain to them why (it can be a shock if not forewarned, but looks great).
4. Paint and trim the room.



## PRIMING & PAINTING

### SAFETY

#### LEAD PAINT

- Lead paint can be present on almost any home, and it is always best to assume that paint is lead based
- Avoid dry scraping paint as much as possible
- Never sand a painted surface, or use a heat gun to remove paint
- Always wear an appropriate mask when working with or removing any material with loose paint

### OVERVIEW

Painting is a rewarding project that provides a drastic difference in how a room looks. A fresh coat of paint in a house will provide the family with walls that are washable and hopefully brighten the home. Painting can be tedious and is a detail oriented project. Special attention should be paid to the preparation and cleanup aspects of a painting project. These two steps are often overlooked, but are critical to a quality paint job. It is ideal to paint a room before installing a new floor; this will prevent any accidental spillage onto the new floor.

#### PRIMER

- Primer is used seal uncoated drywall, to cover stains on existing drywall, and to prepare bare wood for painting (*it seals the wood and allows for paint to adhere to its surface*).
- Kilz is a great primer and is very versatile.

#### PAINT

- ASP uses latex paint for all of our painting projects. It is less expensive, dries faster, and is easier to clean up.
- Paint comes in different sheens. The higher the sheen, the higher the shine; the higher the shine, the easier it is to clean. The different sheens are: flat, eggshell, satin, semi-gloss, and high gloss. High gloss paints are great for areas that get a lot of traffic like cabinets and trim

work. It's easy to clean, but the high gloss shows imperfections in the surface. Eggshell is a good choice for wall paint; it has good coverage and will hide minor imperfections of the surface.

- Always be aware of what is around you while painting. If you don't intend to paint a surface, protect it with a drop cloth.
- Always be prepared to do at least two coats of paint.
- Keeping brushes, rollers, and hands clean will yield better results and make the paint project easier. Brushes should be cleaned each time a stopping point is reached.
- Primer is needed on bare drywall, bare wood, and to cover stains.
- As a general rule of thumb 1 gallon of paint covers roughly 350 square feet

## **PREPARATION**

### *AREA PREPARATION*

It is important to prepare the area in which you will be painting. Always talk with the homeowner first if you will be painting in a room with that contains personal belongings.

- Move all items away from walls. Move items into another room (if possible) or move items to the middle of the room.
- Remove all outlet covers, curtains, pictures, and cover door handles to protect them from paint splatter.
- Use a dropcloth to cover any personal items left in the room.
- Protect the floor with drop cloth if necessary—if current floor covering is to remain

### *SURFACE PREPARATION*

- Any gouges or holes in drywall should be filled or patched
- Surface should be free of dust, oil, and debris. If surface is not smooth before paint is applied, the surface will not be smooth after paint is applied. It is good to wipe down the walls with a damp rag.
- ASP recommends taping edges where paint color changes. Using painters tape on existing baseboard and trim will create sharp paint lines which look great. Taping adds time to the job, but yields high quality results.

## **PAINT TOOLS AND SUPPLIES**

Before beginning any paint project it is important to gather the appropriate tools and supplies. It is important to have plenty of:

### *ROLLERS AND ROLLER COVERS*

- There are several sizes of rollers and roller covers. The mini rollers are great for painting trim and small areas. Nine inch rollers are used for walls and ceilings. Roller covers come

in a variety of materials and thicknesses. Choose a roller cover based on what surface is to be painted. Generally 3/8" to 1/2" nap is a good general purpose roller. The thicker the nap the more paint the roller cover will hold, which is useful when painting textured or rough surfaces. Higher quality roller covers yield higher quality results. A high quality roller cover will last a few paint jobs if cared for properly.

#### *BRUSHES 2" TO 4"*

- Brushes also come in a variety of sizes, shapes, and material. With latex paint, nylon or polyester filaments are the best option. The bigger the brush, the more paint it will hold. 3-4" brushes are good for painting larger areas that a roller can't reach and a 2" angular brush is ideal for cutting in edges and other detail work.

#### *PAINT POLES*

- Short paint poles give you more reach and control—we recommend using them.

#### *WET RAGS FOR CLEAN UP*

- Always have a wet rag handy for cleaning up accidental paint drips.

#### *INDIVIDUAL PAINT CONTAINERS*

- Each brush that is in operation should have its own paint container.

#### *PAINT TRAYS OR SCREENS*

- 5 gallon buckets with paint screens have advantages over paint trays. They are easier to move without spilling, hold much more paint than a tray, and minimize the opportunity to trip over or step into a paint tray.

### **PAINTING TECHNIQUE**

Proper painting technique will increase the quality of the painting project. There is more to painting than just putting paint on the wall.

- The surface to be painted must be clean. For proper paint adhesion, surfaces should be free of dust, dirt, and any type of grease.
- Make sure that paint is thoroughly mixed before beginning. Create a paint pouring station that is well protected from spills and splatters.
- Keep a wet edge. If you let the wall dry midway before continuing, you'll likely see a lap mark where you stopped and started.
- Lay paint on the wall then work to spread it out. Higher quality rollers are more efficient and yield better results.
- Keep roller covers clean and free of debris. If you end up with a lump while painting, wipe it off the wall with a wet rag. Don't allow the roller to touch the floor where it could pick up dirt also watch out for dry bits of paint on the screen. Clean the screen before proceeding.

## WHEN PAINTING WALLS

“Cut in” along all borders of the wall. Using brush paint along the edges of the ceiling, baseboard, window trim, outlet boxes, and in the corners of the walls.

- Using an angled 2” brush makes painting along these edges easier.
- Dampen the bristles of the brush before beginning.
- To cut in along the edges, dip the brush only so that only half of the bristles receive paint and run a line of paint about an inch away from the edge. Apply pressure to the brush so the bristles flair out slightly and draw the paint right along the edge. Grab more paint from the line when necessary.
- Paint 2-3” away from each edge so that when rolling you will be able to roll over most of the brush strokes.
- Work on one wall at a time so that when using a roller the paint around the edges is still wet. Working towards these wet edges will minimize paint lines and hide brush strokes.
- If you need to step away from your painting for a few minutes, wrap the paintbrush in a wet rag and place it in the shade to keep it from drying out.

Using a roller allows you to paint large areas fairly quickly. Special attention should be paid to how much paint is on the roller at all times. Loading a roller to full will lead to drips and runs.

- Load the roller cover by dipping it into the paint about ½” and roll it against the screen. Repeat this process until the roller cover is fully saturated, but not dripping. A dry roller will take more repetitions to load than one in use.
- Lay the paint on the wall with a sweeping stroke. Start about a foot from the bottom and 6 inches from the corner and roll up the wall at a slight angle using light pressure. Stop a few inches from the ceiling then roll up and down to spread the paint laid on the wall. Roll close enough to edges to cover brush strokes.
  - *Starting at an edge with a full roller will leave a heavy buildup of paint that can't be spread out. Work toward edges with roller that is not fully loaded.*
- Reload the roller and repeat the process on an adjacent part of the wall working your way back to the painted area
- After 2-3 swatches have been painted and your roller is not fully loaded, roll back over previously painted area with same long sweeping strokes using very light pressure. This will smooth and blend paint, eliminating roller marks and lightly covered areas
  - *Smooth the paint along ceiling and baseboard using a vertical stroke with the open end of the roller towards the edge. Do not use a fully loaded roller to do this. The closer you can get to these edges with the roller the more consistent the paint will look.*
- Keep working down the wall until entire wall is painted, then move to the next wall.
- Once paint is dry, start the process over again. Always plan on at least two coats of paint. You can place a roller cover in a plastic bag or an old Pringles can to keep the roller from drying out between coats of paint.

## **CLEANUP**

- Paint tools that are cared for properly last longer, make painting easier, and yield better results.
- If paint starts to dry on your brush or roller, immediately clean the dried paint before continuing to use the brush/roller.
- Roller covers can be re-used a few times but eventually will need to be replaced. If a roller has been used several times and is matted it will not hold paint well and should be discarded.
- To clean latex paint off of painting equipment, all you need is water. Do not clean paint supplies on the ground as paint can be harmful to the environment. To be stewards of the environment, paint should be washed down a drain whenever possible.
- If water is not available on site, use three buckets full of water to clean equipment as you would use a three basin sink.

## **BRUSHES**

- Be sure to clean brushes out immediately after you are finished or if you notice paint drying on the bristles of the brush
- Either wash out the paint under running water or in a bucket of water. Gently run your fingers over the bristles to squeeze out as much paint as possible.
- Using a paintbrush comb will help remove paint in the brush as well as any dry paint
- Continue rinsing in water or move to a clean bucket of water until water runs clear.
- Once confident that all paint has been removed, shake out excess water and reshape bristles. Wrap in dry rag or paper towel.

## **ROLLERS**

- Use a roller scraper to squeeze any remaining paint out of the roller.
- Run water over roller, or submerge roller in bucket of water while continue to scrape out any paint from the roller
- Continue this process until water runs clear
- Shake out water and wrap in rag or paper towel to dry.

*(This page was intentionally left blank)*

## TRIM & MOULDING

Trim and moulding are critical components in making a room look complete. Trim and moulding conceal cut edges of the flooring and drywall, the gap between drywall and door jambs and windows, and is a good way to make the transition from ceiling to wall. It is one of the last steps to be done on several projects, but is important in making a room complete. To do a quality job requires some skill, proper tools, and some patience. ASP often uses 1x4 dimensional lumber as trim. This is cost effective and eliminates the need for miter cuts at corners. If 1x4's are used, make sure that you utilize high quality lumber to ensure that paint will apply smoothly and yield quality results.

### TYPES OF TRIM

- Baseboard - installed around perimeter of room above a finished floor
- Base shoe – a narrow moulding installed at bottom of baseboard. Protects bottom of baseboard from damage and conceals uneven lines where the baseboard meets the floor. Great to use when installing laminate.
- Quarter round – Moulding that's 1/4 of a full circle rod and may be used as a base shoe or inside-corner moulding
- Casing- used to trim around the perimeter of doors and windows
- Crown moulding- used to cover the intersection where the walls and the ceiling meet

### TOOLS AND MATERIALS

- Power miter saw
- Fine tooth blade
- Hammer
- Nail set
- Finish nails
- Wood filler
- Sanding sponge
- Tape measure
- Utility knife/pencil

## HOW TO INSTALL PRIMED PINE BASE MOULDING

Primed pine base moulding is a little more expensive and requires a little more skill to install. However, primed moulding cuts down on painting time which makes for quicker installation. This is a great option for new additions or other projects where a more modern look is desired. To install primed pine base moulding:

### PREPARING TO INSTALL

1. Set up saw horses and lay primed pine moulding across. Apply a good coat of semi-gloss or high-gloss paint using a 3" roller
2. While trim is drying, plan which pieces of trim will go where and if you can use the waste from one cut on another section of the room.
3. Example: If using 12' baseboard in a 8'x 8' room with a 2' x 4' closet; the waste from one 8' wall can be used on a 4' wall in the closet.
4. Try to avoid seams in the middle of walls while installing trim. Using 12' sections of trim should eliminate the need for splices in several rooms.
5. Protect the floor in your work area. It is best to have power miter saw in the room where trim is being installed to save steps.
6. Mark stud locations with masking tape.

### FASTENING

- Whenever possible, fasten trim into studs so that the trim is held tightly to the wall. Fasteners can be driven through trim into the bottom plate; however, this sometimes causes the top of trim to kick out away from the wall.
- To make a trim job look great, all of the nail penetrations need to be hidden. To do this use small, appropriately sized fasteners in addition to wood filler.
- Types of fasteners to use

#### FINISH NAILS/ NAIL SET

- 6d finish nails have small, easily concealable heads. Take care not to hit trim with hammer. Drive nail until flush with trim.
- Once nail is flush with trim use a nail set to counter sink the nails, then fill the void with wood filler.

#### TRIM SCREWS

- Drive screws through trim into stud, counter sinking screw into trim piece.
- Once screw is driven, fill the void with wood filler.

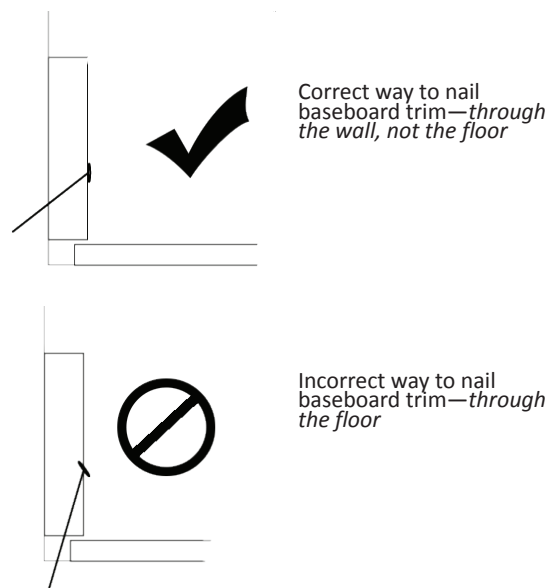



### CUT AND INSTALL OUTSIDE CORNERS

*Tip: Using a measuring tape allows for a margin of error. Instead, try holding trim pieces in place and marking them directly from wall edges to make cuts.*

1. Rarely are corners a true 45°, often a steeper cut is required to eliminate a gap on outside corners. Start with 45° cuts on both pieces of baseboard. Check fit, cut a steeper angle if needed to eliminate gap on outside corner.
2. If cutting a trim piece that is inside and outside corner, cut inside corner bevel first then hold piece in place to mark where outside bevel will be cut.
3. Hold adjacent pieces tightly against wall, ensuring corner is tight, and fasten to studs.

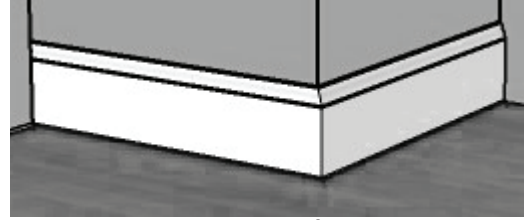

Outside corner

### CUT AND INSTALL INSIDE CORNERS

The method we use for inside corners is to make two bevel cuts and create a miter joint in the corners.

1. Many pieces of trim will have a bevel cut on both ends. One running into the inside corner and another for a splice or outside corner. In some cases both ends of trim will be part of an inside corner. Regardless of the situation, make sure the bevel fits securely into the corner so that the other 45° bevel will create a crisp 90° corner with minimal gaps.

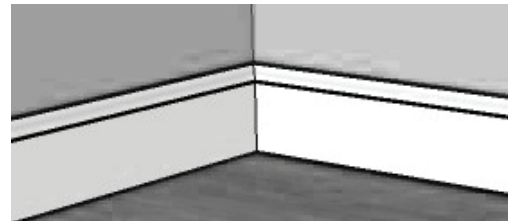

Inside corner

2. Fit both sides of the inside corner and install fasteners into the studs.

### TO SPLICE TWO BASEBOARDS ON LONG WALLS

1. Be sure to mark stud location, splice must occur over a stud
2. Cut a 30° bevel into each trim piece so that each piece fits tightly together
3. Fasten both pieces of trim into studs

### BASE SHOE

**NOTE: FASTEN BASE SHOE TO BASEBOARD, NOT TO THE FLOOR. This is critical for allowing laminate flooring to expand and contract.**

*Tip: It may be necessary to pre-drill holes if using screws in base shoe to prevent the base shoe from splitting.*

1. If using base shoe, follow the same procedures for inside and outside corners as you would installing baseboard
2. Base shoe will come out further from the wall than door casing.
3. Cut 22.5° bevel where base shoe meets door casing

## CAULKING

Caulk makes a trim job look complete. It is used to close gaps and seams—things like gaps in corners, where moulding meets with the wall, divots made by fasteners, etc. It is important to take your time while caulking, be prepared with plenty of wet rags, and protect the floor from drips. There are several types of caulk available. **ASP recommends that you choose a white, acrylic latex caulk that it is paintable.**

1. Cut the tip off of the top of the caulking tube. Caulk guns are equipped with a cutting tool on their handle. Cut roughly  $\frac{1}{4}$ " off the caulk tube at a slight angle. This angle will allow for smooth application.



2. Once the tip of the caulk tube has been cut off, use the poking tool attached to caulk gun to break the seal of the tube by sticking down the tip of the caulk tube.
3. You will caulk seams between baseboard and wall/ baseboard and base shoe. Hold the caulk gun at a 45° angle from the wall and floor, with the angle that was cut at the tip in the corner where caulk is to be applied.
4. Start at the corner and lightly apply a bead of caulk moving the caulk gun down the seam while applying steady pressure to the trigger of the caulk gun.
5. The goal is to get the caulk into the seam. It's easier to add more caulking rather than remove. A small cut in the tip will allow you to better control the amount of caulk being applied.
6. Once the bead is applied, smooth it out using a wet finger. This will wipe off any excessive caulking and make the seam disappear.

***Note: Ideally there is not much excess to remove, rather you are just smoothing it out.***

7. Fill all fastener divots with a small amount of caulk and wipe off excess with wet finger.
8. Work in one direction so that you are always finishing the caulk in the same direction. This will eliminate high spots in the caulk. Work in 3-4' sections, being sure fill all corners and fastener divots as your work around the room.
9. Make sure to keep your hands and the tip of the caulk gun clean. Keep plenty of wet rags on hand.

***Note: After the caulk dries, you may need to touch up imperfections with the same paint that was originally used on the trim/moulding.***

## HOW TO INSTALL 1X4 PINE AS BASEBOARD

Using 1x4 as baseboard is a cheaper alternative to moulded baseboard. Special attention should be paid to make sure that the outcome will yield a quality finished result. Often hardware stores will sell low-quality 1x3 or 1x4 material that will not yield good results if used as baseboard. A higher quality 1x4 should be selected to minimize warps, knots, and bows in the lumber. Better lumber will also yield better results when painted.

### PREPARING TO INSTALL

1. Set up saw horses and lay 1x4 lumber across. Apply a coat of primer on the 1x4's.
2. After it has dried, apply at least one coat of semi-gloss or high-gloss white paint.
3. While trim is drying, plan out which pieces of trim will go where and determine whether you can use the waste from one cut on another section of the room.

*Example: If using 12' 1x4 in a 8'x 8' room with a 2' x 4' closet; the waste from one 8' wall can be used on a 4' wall in the closet.*

4. Try to avoid seams in the middle of walls while installing trim. Using 12' sections of 1x4 should eliminate the need for splices in several rooms.
5. Protect the floor in your work area. It is best to have power miter saw in the room where trim is being installed as it will save you walking back and forth between rooms and/or outside.

### FASTENING

Fasten 1x4 to the studs using the same process as attaching moulding to studs.

### CUT AND INSTALL OUTSIDE CORNERS

Instead of using miters cuts to join at outside corners, two crosscuts can be joined to make the outside corner. The first 1x4 will line up with the edge of the corner and the second 1x4 will extend 3/4" past the corner, covering the cross cut of the first trim piece.

### CUT AND INSTALL INSIDE CORNERS

Two crosscuts are also used at inside corners. The first 1x4 will butt up in the corner of the wall. The second 1x4 will butt up to the first 1x4.

### CAULKING

The caulking process will be the same as in the previous section.

**Note: After the caulk dries, you may need to touch up imperfections with the same paint that was originally used on the trim/moulding.**

## **INSTALLING 1X4 AS CROWN MOULDING**

If installing drywall in an addition or in a room in which you would be required to tape between the wall and ceiling; we recommend using 1x4 as crown moulding to cover this gap instead of tape. Taping this joint is difficult and time consuming. Using 1x4 in place of tape will usually yield better results and reduce the amount of time spend taping and finishing drywall.

The process for installing 1x4 as crown moulding is the same as if you were installing it as baseboard, except it is installed at the top of the wall. You will also need to caulk both seams: the seam on top next to the ceiling and the seam on bottom next to the wall.

# EROSION, DRAINAGE & GUTTERING

## EROSION AND DRAINAGE

- Erosion: the washing away of soil/rock over time through the impact of water or wind. Water is the primary cause of erosion.
- Drainage: the controlled removal of water from an area, thus preventing erosion.

Erosion and drainage are typically handled in the following ways, either as a stand-alone method, or best implemented together:

- Ground cover: the use of plants to slow the travel and ground water and sub-surface runoff.
- Drainage ditch: an in-ground trough used to transfer water from the base of a house or hill to a less critical area of flow.
- Retaining wall: a structure built to deter erosion from steep slopes where erosion is already occurring or is threatening the home.
- Guttering: a system of troughs used to divert the water shed from the roof away from the foundation of a home.
- Positive drainage: using sloped soil to divert water from the foundation of a home. The soil is banked at a 1 to 4 pitch. You need 1 foot of drop for every 4 feet away from the house.  
*This is a requirement on all houses on which we work.*

## GROUND COVERING

Plantings are a great way to help slow the erosion of a hillside over time. There are a variety of species out there that can do this, and the best way to find out about what would work best in your area is to contact a local expert in the community, either a landscaper or someone at a local nursery. Listed below are some plants that are commonly recognized for their erosion control properties.

- Ground covers: these are used for surface soil retention, and tend to have rather shallow root systems. Included are ivy, periwinkle, crown vetch, grasses, and yarrow.
- Small shrubs: these are used for soil retention and limited hillside stabilization, these plants have larger root systems and can actually begin to hold more than topsoil in place.
- Large shrubs and trees: these can be used for hillside stabilization, but typically require a longer period of growth before they become truly useful. With large root systems, they are able to actually hold back erosion of hillsides.

Again, before planting any variety of plants, check with local growers, and talk to the homeowner about maintenance and future issues that may arise.

## **DRAINAGE DITCHES**

Before construction of any drainage ditch, you must have a clear plan of where the water will be diverted to, and make sure that the runoff will not disrupt someone else's home. Check with local codes and inspectors. We can't push water into the neighbor's yard.

Drainage ditches require a minimum of 2' distance from the foundation of the home and should be placed perpendicular to the flow of water off the hill. The point is to redirect the water, so first we must catch it.

The ditch should have a slope of 1" for every 10' it travels, sloping away from the house to divert water.

If it makes sense, the ditch can be placed higher up the hill to follow the contour of the land and more effectively prevent erosion.

Typically, we do not use corrugated pipe in the ditch as we have found that they fill up with silt and lose their effectiveness after a couple of years.

1. Plan the layout of the ditch, determine the lay of the land and where the ditch will peak and terminate. Using marking paint, mark clearly on the ground the layout of the ditch.
2. Have the utility companies come out and mark all utility lines. If hit, you are usually responsible for repairs, which can take time and be costly. Make sure to plan well ahead of time just in case it takes them a while to come out and mark. Also, talk to the homeowners about septic lines, tanks, and fields, as these are messy business.
3. Begin digging the ditch. The high point of the ditch must be 6" deep, and drop down from there. The ditch should be 12" across, and never less than 6" deep.
4. Lay some sort of membrane down in the ditch, either a waterproof landscaping material, or even housewrap/underlayment. This will help the water to flow. Then, fill the ditch with gravel.

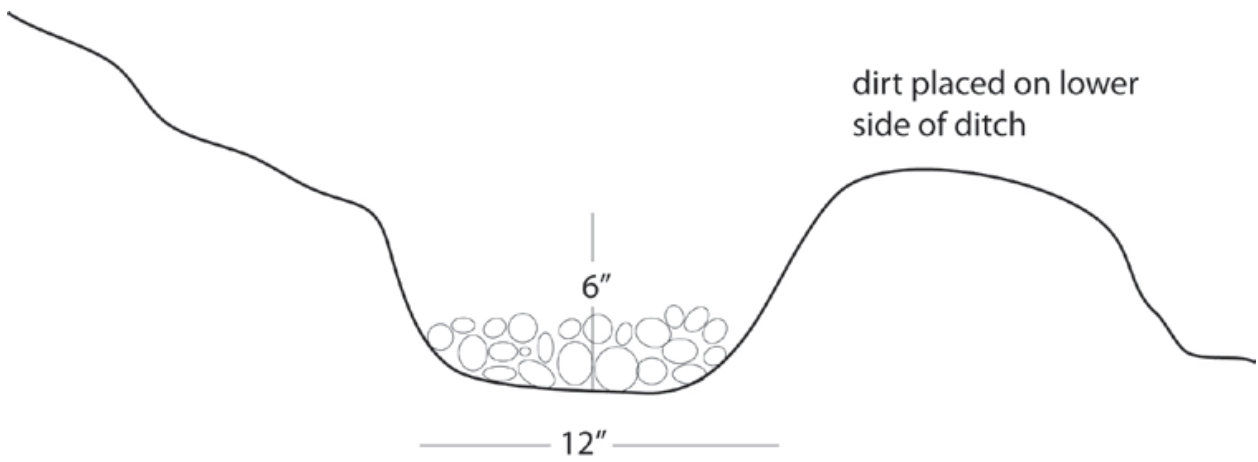
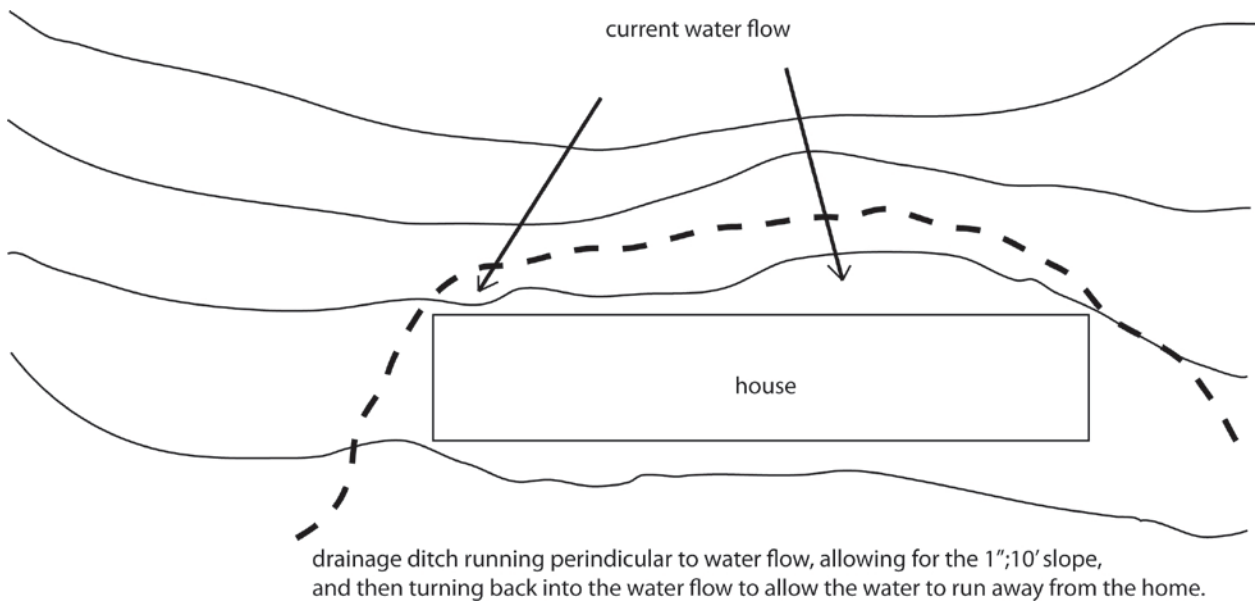

## RETAINING WALLS

Retaining walls are used to prevent the earth from eroding and building up against a house. There are a variety of ways to construct retaining walls, including concrete block, rock, or lumber.

**In the past, ASP used railroad ties. We have since determined that this is a dangerous method for many reasons, and it is no longer a recommended form of retaining.**

The most straightforward method of construction is with 4x4 or 6x6 posts and treated 2x lumber. It is important to get ground treated lumber, as this will most definitely be in contact with the earth. Do not build a retaining wall over 3' tall without receiving prior approval from ASP's main office.

1. Plan the layout of the retaining wall. There will need to be a gravel filled pit between the wall and the hill, as well as a drainage ditch on the house side of the wall.
2. Cut back the hill if the slope requires it. This could be if it is close to the house, or is extremely steep.
3. Dig post holes 16"Wx 16W"x24H" for the posts. Set them in solid concrete, for it is the mass of the concrete that really helps to hold the wall up. The posts should be no more than 6' apart from one another.
4. Attach 2x lumber to the back of the posts, on the hillside. Make sure to use exterior fasteners, and to attach them well.
5. Drill 3/4" holes 6" down from the tops of the posts. These are where the cable will be pulled through. Attach the cable back into the hill using mobile home tie downs. The mobile home tie downs should be parallel with the cable, not perpendicular to it. Attach with cable clamps, and turn buckles. The cable will be in 2 sections; one coming from the tie down and one coming from the post. The turn buckle attaches these sections together and tightens the cable.



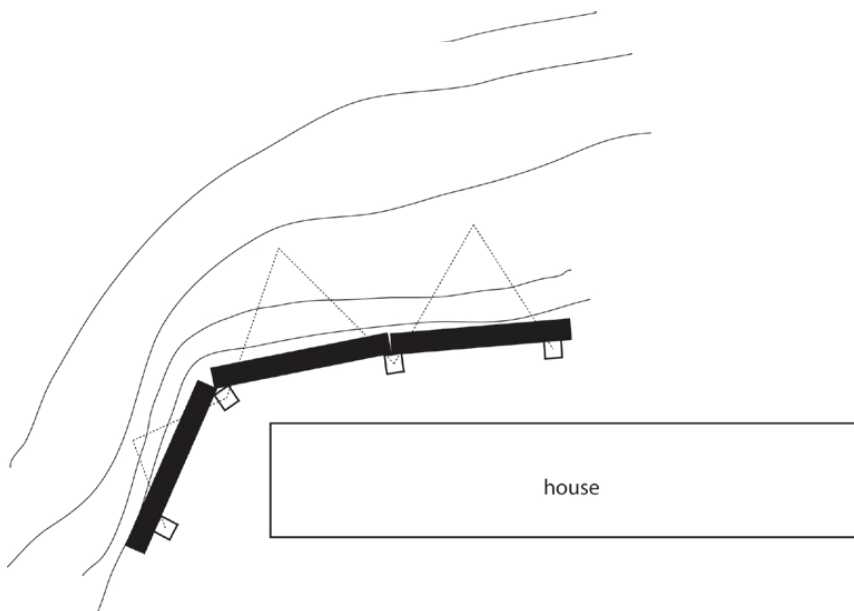
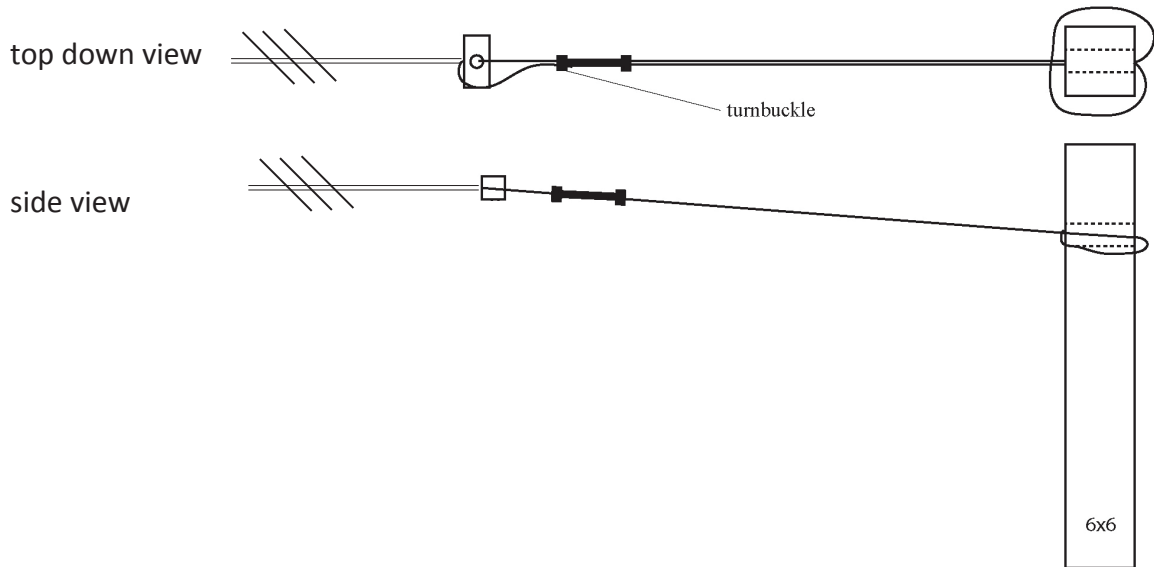
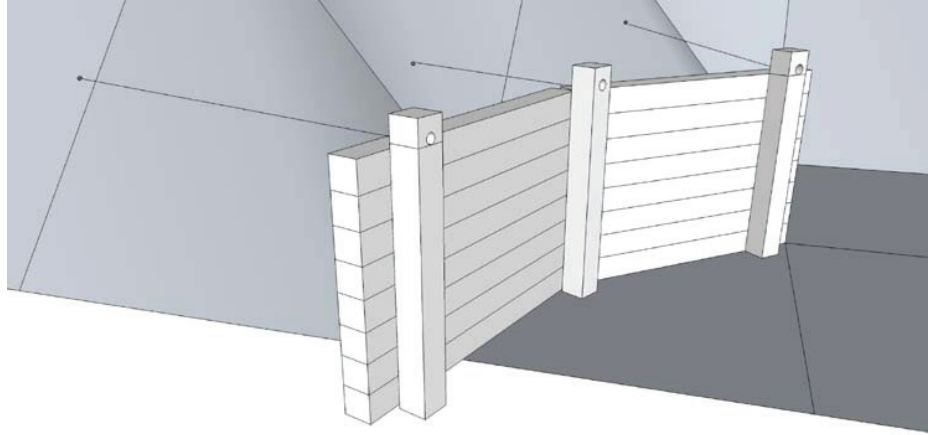

## GUTTERING

It is critical that water not be given an opportunity to collect at the base of the house. Guttering is designed to divert the large volumes of water collected by a house's roof away from the foundation. The gutter must attach under the gutter apron or drip edge to be effective.

### INSTALLING GUTTERS

1. Stretch a chalk line along the length of the fascia. Use a line level or carpenter's level to level the string.
2. Lower one end of the chalk line to allow  $\frac{1}{2}$ " of drop for every 20' of gutter length. Snap this line. The gutter just needs to drop enough to have the water flow.
3. Beginning at one end and working toward the other, screw or nail the hangers along the chalk line. Gutter hangers should be installed every 24". Starting at the high point of your line, install the back of gutter tight under the gutter apron, between the fascia and the gutter apron. Water must flow from the roof into the gutter. It may be necessary to install a 2" drip edge or gutter apron.
4. A drop of  $\frac{1}{2}$ " for every 20' of gutter should be maintained. If the gutter is longer than 35', create a high spot in the middle of the fascia and slope towards down spouts at both ends.
5. Gutters come in 10' sections. Use slip connectors to join two sections. Slide the gutter sections into the connector. Drill two holes through the front of each seam (there will be a total of four rivets in every connector) then seal those holes with pop rivets. Another method is to use  $\frac{1}{2}$ " self tapping metal screws in place of pop rivets.
6. All seams should be caulked with gutter cement.
7. Install dropout assemblies to transfer the water from gutters to downspouts. They should be joined with the same drill/rivet/cement method as described in steps 5 and 6 above.
8. Use gutter cement but no pop rivets to attach left and right end caps at each end.
9. Downspout seams also use pop rivets or screws. Install a combination of elbows to bring the downspout close to the wall of the house, male into female, and then strap the downspout to the house using downspout straps.
10. Use splash blocks, downspout extensions, or underground drainage to carry water away from the house.

NOTE: We have found guttering to be one of the most difficult projects we do. An alternative to guttering is to use positive drainage using stone to create the slope. The water from the house will fall directly onto the stone (called "drip line") and then be diverted away from the house.



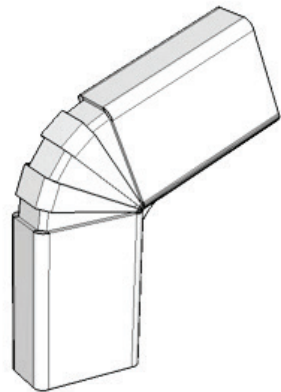
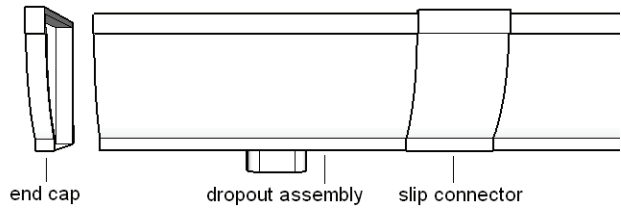

B-elbow

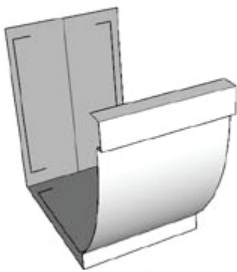

slip connector

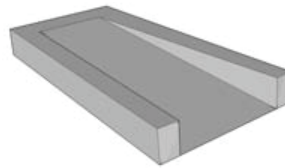

splash block



downspout

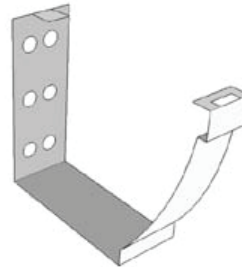

fascia bracket

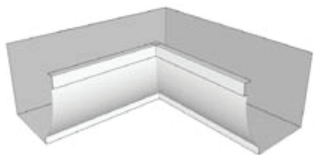

inside corner piece



gutter hanger

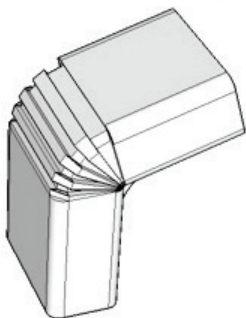

A-elbow

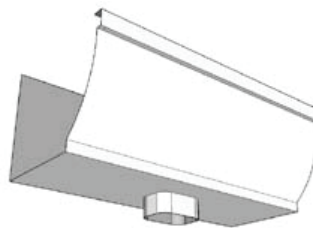

downspout assembly

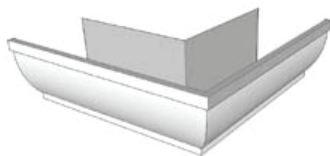

outside corner piece



90°

shoe

*(This page was intentionally left blank)*

# VAPOR BARRIER, UNDERPINNING & SKIRTING

## SAFETY

- Always use earplugs and gloves when metal is being cut, transported or installed
- Metal cutting shears are the safest tool for cutting metal
- A circular saw with a blade designed for cutting metal may also be used. ***DO NOT turn saw blades backwards to cut metal.***
- Ensure that the piece being cut is in a safe working location, away from any combustibles and sufficiently secured

*NOTE: In many areas underpinning refers to a structural component. Skirting is not structural and refers to a component that keeps wind and animals from underneath homes. Both terms are often used interchangeably. **In this manual ASP uses the terms interchangeably.***

## VAPOR BARRIERS AND UNDERPINNING

Underpinning, or skirting, is a vertical barrier that covers the exterior open area of a building below the floor. Underpinning provides a wind barrier and keeps animals out from underneath the home. It is not a structural component and is not used for insulation.

Vapor barriers protect the underside of the home from ground moisture. Venting allows for any trapped moisture to escape from underneath the home.

### VAPOR BARRIER

A vapor barrier should be installed directly on the ground underneath all new additions; it should be made of 6mm plastic.

Vapor barriers should not be used underneath mobile homes where there is plastic attached to the underside of the floor joists.

1. Roll the plastic out underneath the house/addition. Roll the plastic up around the foundation and any piers.
2. Using duct tape, fasten the edges of the vapor barrier to the piers as well as the foundation. This will ensure moisture stays down on the ground.
3. Overlap any seams by at least 12”.

## INSTALLING UNDERPINNING

ASP is using 2 different ways to underpin a home: vinyl underpinning or metal underpinning.

*NOTE: If skirting will extend 36” or more from the ground to the bottom of the home, more structure is required. Install vertical 2x4’s every 4’ AND install horizontal 2x4’s at about 18” high between the vertical pieces. If the height is more than 60”, more than one horizontal piece is necessary. Place a horizontal piece at 20” and another at 40” from ground. (see diagram at right)*

### VINYL UNDERPINNING

1. Remove any old underpinning that may still be in place, as well as anything that may be under the house that will get in the way.
2. Install a 2x4 top plate approximately 1” back from the outside of the mobile home. Lay flat against the bottom of the floor joists, and attach with 3” screws, or 12d nails, (though these may be more difficult to use).
3. Attach J-channel to the 2x4s that will act as the top plate, using nails or screws.
4. Mark the ground for the bottom plate. Use a plumb bob to make sure that you are directly under the top plate.
5. Install the bottom plate on the ground using treated 2x4s. You can use any length for the bottom plate. Every 6’, or at the ends of pieces shorter than 6’, drill a ½” hole, and pound a 8” stick of rebar through it into the ground. This will keep the board in place. **BE AWARE OF WHERE UTILITIES ENTER THE HOME. MAINTAIN A THREE FOOT SETBACK/DISTANCE FROM ANY UNDERGROUND UTILITIES WHEN POUNDING REBAR INTO THE GROUND.**
6. Dig a narrow trench outside the bottom plate about 2” deep to stick the bottom of the vinyl into.

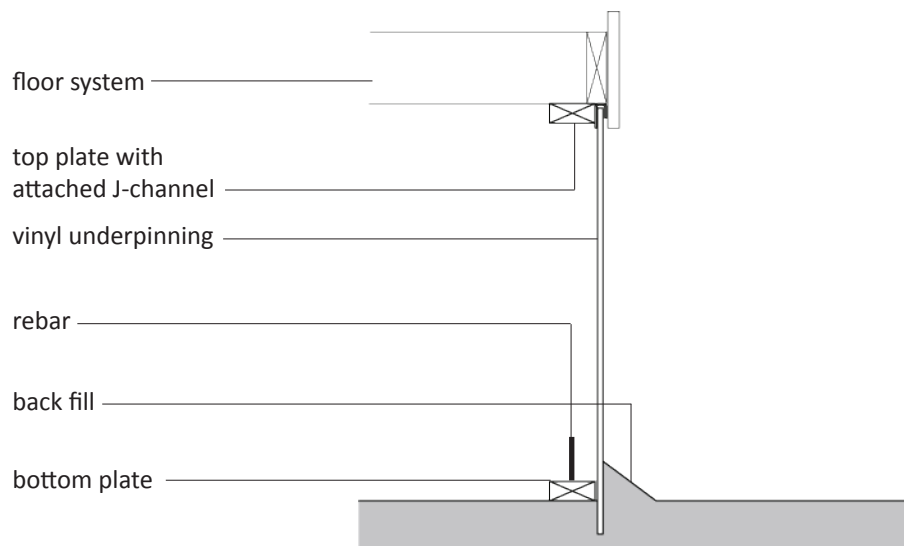
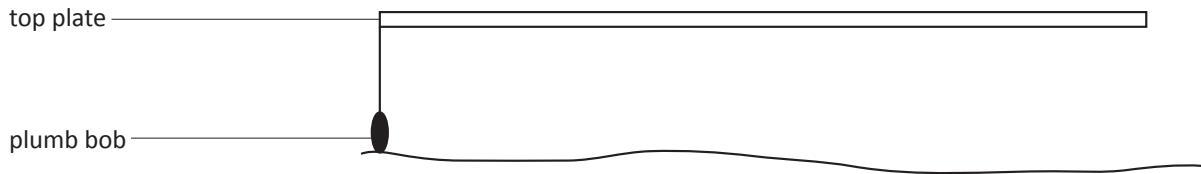
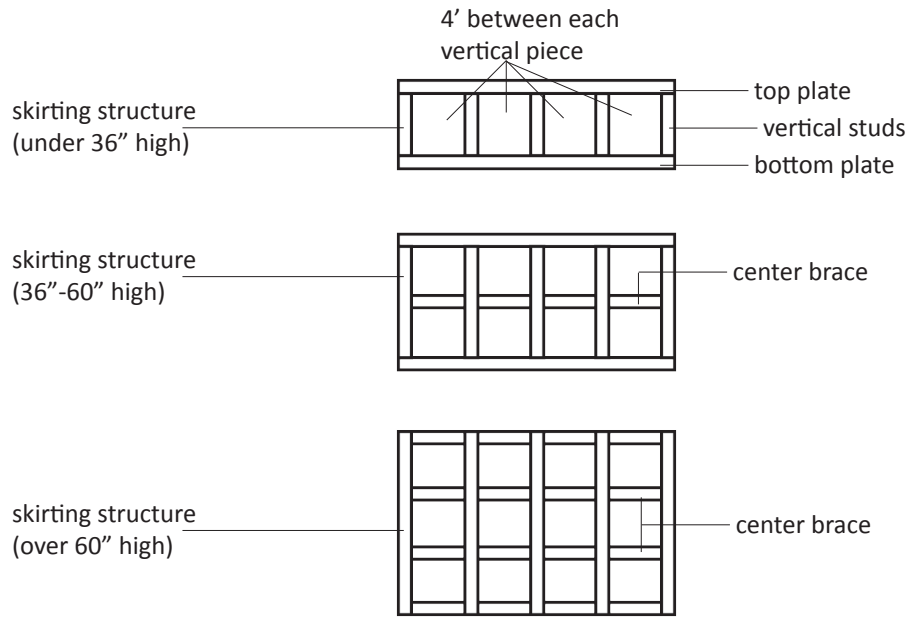

7. Begin attaching the vinyl pieces, measuring the height that each piece needs to be, marking it on the vinyl, and cutting with tin snips. Work from one side to the other, as the pieces are difficult to make meet in the middle. The vinyl should run vertically, and clip into the next piece. Staple the bottom plate to the vinyl, and make sure that each piece runs into the ground. Pieces 3' from each corner should be vented, as well as a vented piece located in the middle of the house.
8. Attach the outside corner pieces to the corners of the home, making appropriate modifications so that rain will not get in. This requires you to snip down into the corner piece and fold it up underneath the corner of the home. Then caulk that area.
9. If the vinyl is not all one color, you can paint it. Use exterior acrylic paint, and make sure to cover the vinyl well. It must be painted before attaching it.
10. When finished, backfill up against the vinyl, making a mound of dirt that will slope away from the house so that any water will run away from the underpinning. The slope is at a 4 to 1 ratio. For each 4 foot away from the house the land should fall 1 foot. We need positive drainage away from the house.

### METAL UNDERPINNING

Underpinning consists of sheets of metal attached to a 2x4 plate on the house, and a 2x4 plate attached to the ground.

The frame is made with 2x4s, and consists of a top and bottom plate. No vertical members are required unless the height between the ground and the house is more than 48". We will cover this later in this section. The bottom plate needs to be pressure treated because of its direct contact with the ground.

Assume that 36" is the shortest length of metal that can be ordered without extra charges for short lengths. Therefore, if you need 22" lengths, order 44" and cut it in half, or 66" and cut into thirds.

*If the underpinning will be higher than 48", install vertical 2x4s every 8' along the side between the top and bottom plates. Then install a 2x4 horizontally between these pieces, about half way between the top and bottom. This will give support to the metal. Screw the metal to this 2x4, as well as to the top and bottom plates.*

1. The top plate is secured to the underside of the house 1" in from the vertical plane of the existing siding on the house. This top plate is attached around the complete perimeter of the house. Most ribbed metal is  $\frac{3}{4}$ ", so the plate in 1" will keep the metal behind the vertical plane of the trailer. *(When working on a mobile home, the outriggers may interfere with using a long top plate. If this is the case, cut the top plate to fit between the outriggers.)*
2. Then, starting at a corner, hold a plumb bob on the outer edge of the top plate (1 inch in from the vertical face of the trailer) and down to the ground. This line will be where outside of your bottom plate rests. This will give you your placements for the top and bottom plate at that corner.
3. Continue this procedure on both sides of each corner of the house and at the inside and outside corners.
4. This bottom mark can then be carried around all sides of the home. One way to carry this mark is to hold a dry line tight from corner to corner. This will give you a straight line to follow when placing your bottom plate.

Another way is use the plumb bob about every 16' feet or so. This will give you a line on the ground to follow. The goal is to produce an underpinning wall that is solid, straight and plumb.



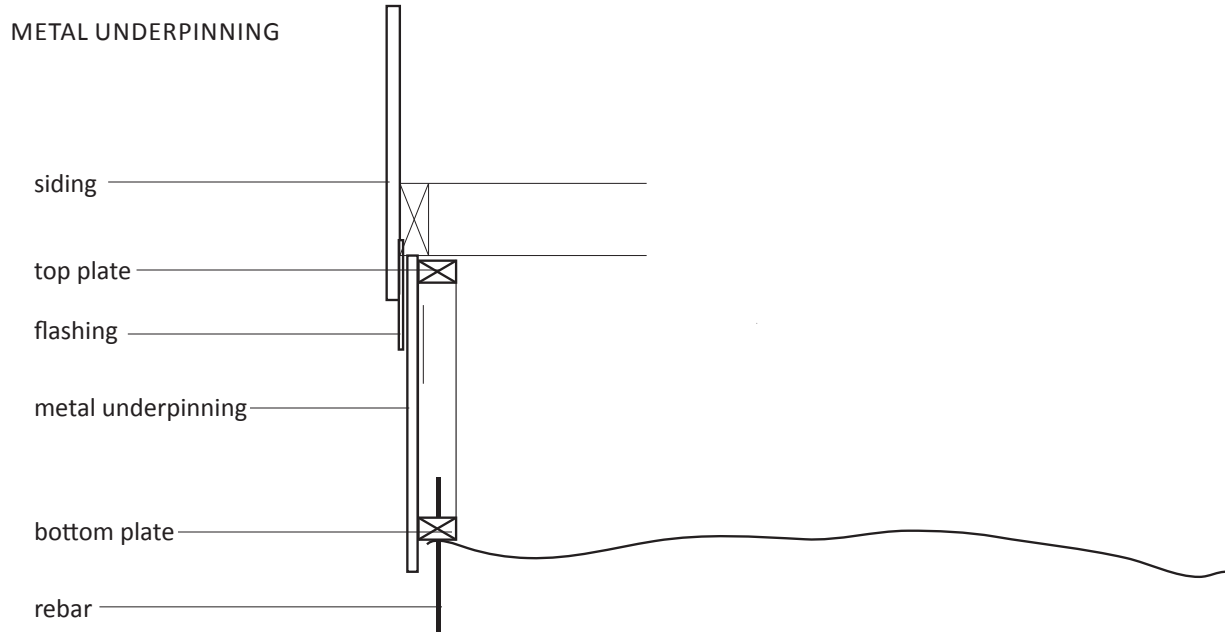
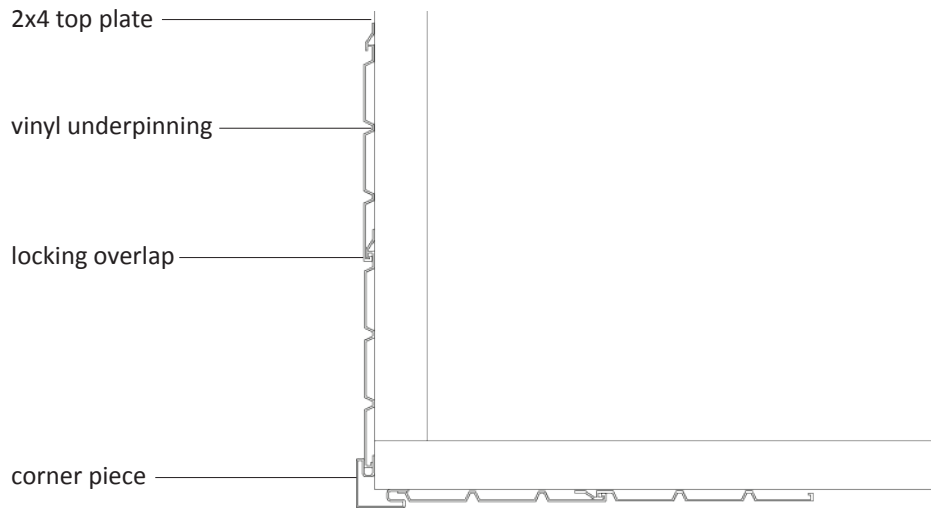

5. The bottom plate is fastened to the ground every 6' with ½" rebar driven 8" into the ground. It sits on top of the ground (not in a trench), and the sheets of metal are embedded an inch or two into the ground to prevent wind flow under the house. **BE AWARE OF WHERE UTILITIES ENTER THE HOME. MAINTAIN A THREE FOOT SETBACK/DISTANCE FROM ANY UNDERGROUND UTILITIES WHEN POUNDING REBAR INTO THE GROUND.**
6. The metal to be used is Galvolume roofing metal running vertically with screws at the top and the bottom.
7. The metal will be fastened into place using sheet metal screws. Overlap each piece of metal per manufacture recommendation. One screw per flat section is all that is required.
8. An 18" x 24" (minimum) access door should be installed in the underpinning to allow for entry. This access door should be in the vicinity of the plumbing to allow easy access.
9. After the underpinning is installed, the top of pieces of metal need to be covered. The easiest way is to take a roll of 6" flashing and slide it under the siding and over the underpinning.

### *VENTING THE UNDERPINNING*

Underpinning needs to be vented on both sides and both ends of the trailer.

If using rectangular vents, they need to be placed at opposite corners and within two feet of the corner. Use 6" vents and place them vertically between the ribs of the metal, near the top. Most mobile homes require at least 10 vents. The vents can be made by taking a galvanized 8"x16" vent and cutting that vent into three pieces, and attaching those pieces to the metal between the ribs. Use silicone caulk to seal the vent.

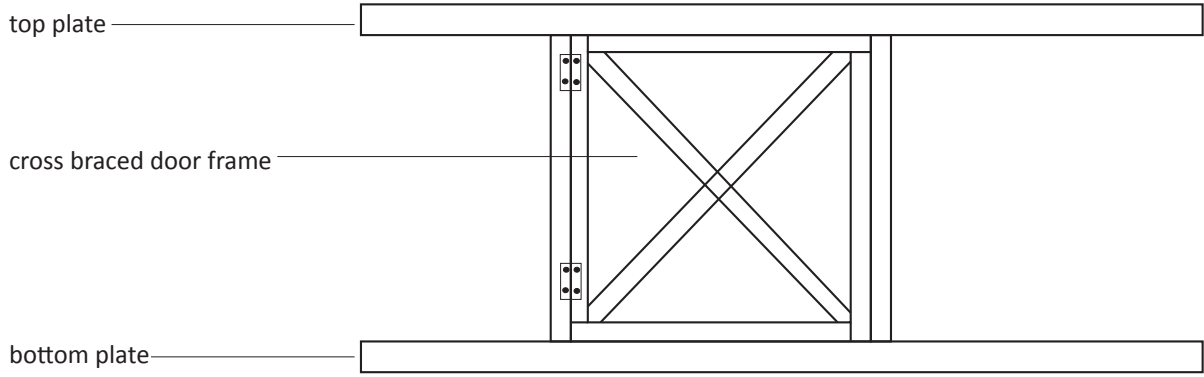

VENTING PATTERN FOR VINYL UNDERPINNING

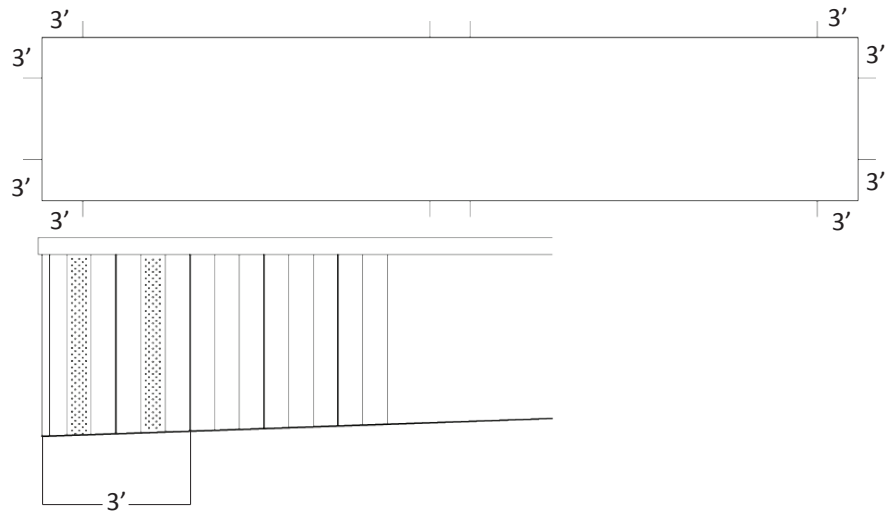

VENTING PATTERN FOR METAL UNDERPINNING

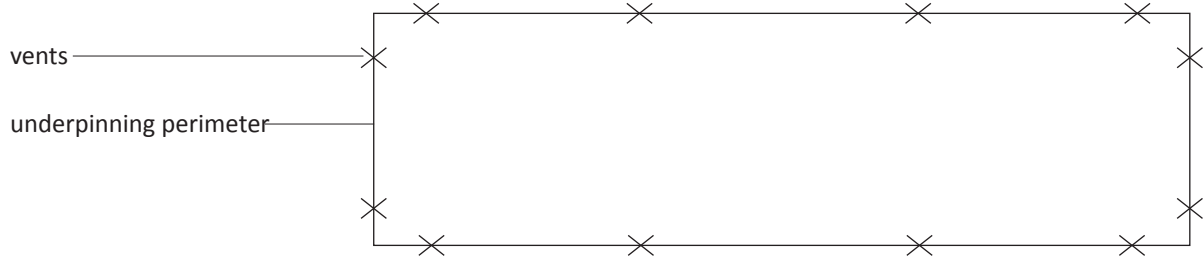

*(This page was intentionally left blank)*

# PORCHES

## SAFETY

- Drills will need to be used, ensure that when drilling a large hole, the appropriate gauge extension cord is being used (*especially when using a hammer drill*)
- Make sure a good station has been set up for cutting boards and especially posts
- ***DO NOT USE A TABLE SAW TO RIP SPINDLES. IT MAKES THIS WORK MUCH MORE DANGEROUS. DON'T DO IT!***

## **PORCHES**

Porches provide a huge service to families in Appalachia. They provide safe exits, act as outdoor living spaces, and are generally loved by the homeowners.

Porches are always built of treated lumber. The most economical dimensions for a new porch are 6'x10', though other sizes can be constructed. The smallest porch that should be built is 5'x5' to act as a landing for a set of stairs, and also as a landing for a ramp.

### *PLANNING*

Building a porch utilizes many of the same techniques that have been covered in previous sections.

It is important to develop a complete plan before beginning the project. Consider the following:

- the location and dimensions of the porch
- the height of the porch
- post placement
- how the porch will come into contact with the home
- where the stairs/ramp will come off the porch
- is a large porch needed

### *FOUNDATION*

When planning post placement, determine where stairs are going to be placed and how the handrails will be installed.

Post selection:

- 4x4s when the height of the porch is less than 8'
  - 6x6s when the porch is over 8' high. Porches of that height must be approved by the Construction Consultant, Program Manager, or Home Repair Coordinator.
1. Build the outside frame of the porch to use as a template for post placement. Make sure to measure and check that the frame is square (see the framing portion later in this section).
  2. When using 4x4s, dig a 12"x12"x24" hole; for 6x6s, dig 16"x16"x24".
  3. Place a split cap block, castle block, or 3" of Sakrete (put in dry) in the bottom of each leveled hole.
  4. Install the posts on top of the cap block or in the post boot, using post levels to make sure the posts are installed correctly. Fill and tamp the holes in order to secure the posts in place. In most areas, concrete around the post is not a requirement, and will shorten the life of the post. Check with the local building inspector if the porches are to be inspected.
  5. Lift and fasten the outside of the porch frame into place, temporarily screwing into place before installing bolts. Check that the porch frame is still square and completely level. The frame of the porch should sit 1.5" below the sill of the door. If the porch is lower than 1.5" it can create a tripping hazard.

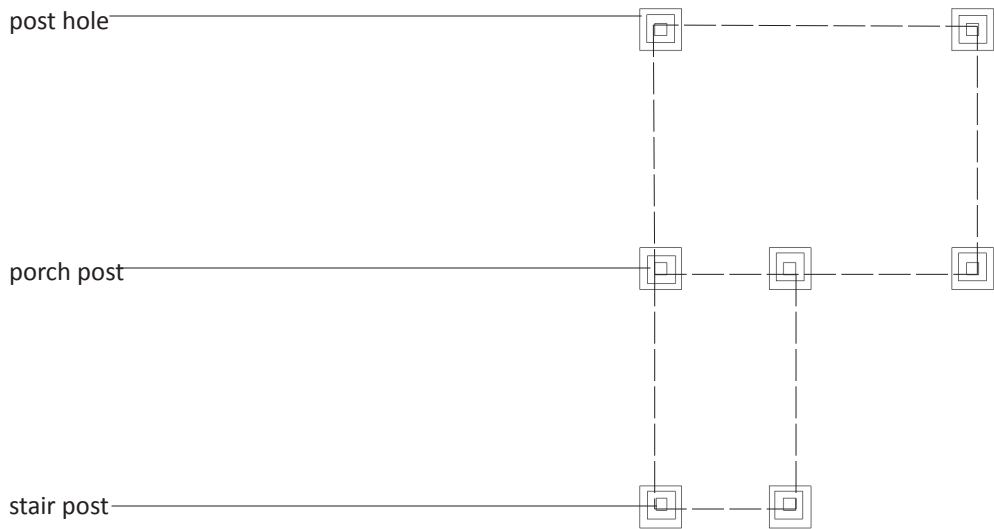
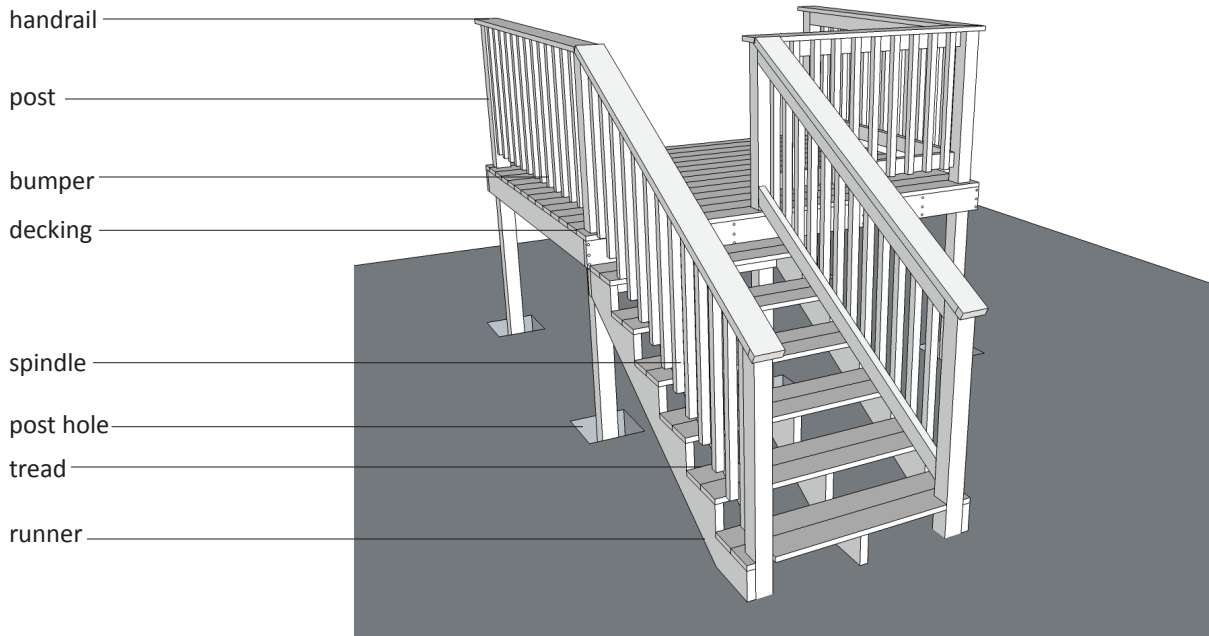

## PIER BLOCK

Some situations may require using pier blocks for porch or ramp construction. Pier blocks serve as an above ground foundation for posts and can be beneficial in some situations. To create pier blocks you will need a relatively level ground level, 2x6 lumber, concrete, fasteners, and a post base (Simpson PB44Z).

1. Cut two 15" sections of 2x6 and two 12" sections of 2x6. Fasten these together to create a 12" square form.
2. Set the form on level ground and fill with concrete. Once form is filled with concrete press post base into concrete in center of the form. Making sure that bottom of post base stays above the concrete.
3. Allow to cure for 24 hours and move into place. Attach posts to post base using either deck screws or LedgerLoks.

## FRAMING

Porch framing follows the same principles use in framing a floor. Make sure to build the frame *first* in order to correctly set the posts. Doing this will ensure dimensions are exact when porch is constructed, making ordering lumber easy and efficient. We generally do not attach our porches to the house because of codes, water retention, etc. We also like to leave a 3/8" to 1/2" space between porch frame and house to allow water to escape and not accumulate.

1. Plan the size of the porch so that you are either using full lengths or half lengths of lumber. The joists should be a minimum of 2x6's (see span chart at right).
2. Screw the rim joists and band joist together creating a box. This box will allow you to accurately dig post holes in each of the four corners and one for the stairs.
3. Set posts then lift the frame into place, checking that it is level and square. To check for square, measure the diagonals of the porch; they should be the same distance from corner to corner. Take care to ensure posts are plumb as well.

**WHEN RAISING FRAME INTO PLACE MAKE SURE THAT THE LEVEL OF THE FRAME IS 5/4" (1 1/4") BELOW DOOR SILL. TO DO THIS, SET A DECKBOARD ON TOP OF FRAME WHILE DETERMINING HEIGHT TO MOUNT IT AT. THE DECKBOARD SHOULD BE JUST BELOW DOORSILL WHEN FRAME IS IN PLACE.**

4. Temporarily screw the frame to the posts, checking that the posts are still plumb.
5. To permanently secure frame to posts use two 3 5/8" LedgerLoks per piece of lumber per post. (Corner posts will have 4 LedgerLoks driven into them)

**THERE WILL NOT BE ENOUGH CLEARANCE TO INSTALL LEDGERLOKS INTO RIM JOIST AGAINST HOME. INSTEAD INSTALL ANOTHER COMMON JOIST ON INSIDE OF POSTS AND USE LEDGERLOKS TO INSTALL IT.**

6. Install the common joists using joist hangers. The common joists should run parallel to the house, so that the decking can run perpendicular to the house. If the decking runs perpendicular to the house there is less chance of water collecting near the house. It can escape through the spacing in the decking.



| FLOOR JOIST SPAN DATA |                              |                                   |  |
|-----------------------|------------------------------|-----------------------------------|--|
| NOMINAL JOIST SIZE    | SPACING IN INCHES ON CENTER* | MAXIMUM ALLOWABLE SPAN            |  |
|                       |                              | MEDIUM GRADE SOUTHERN YELLOW PINE | SOUTHERN YELLOW PINE WITH DRYWALL ATTACHED |
| 2X6                   | 16"                          | 9'4"                              | 8'0"                                       |
| 2X6                   | 24"                          | 8'1"                              | 6'6"                                       |
| 2X8                   | 16"                          | 12'3"                             | 10'6"                                      |
| 2X8                   | 24"                          | 10'3"                             | 8'9"                                       |
| 2X10                  | 16"                          | 15'5"                             | 13'8"                                      |
| 2X10                  | 24"                          | 12'7"                             | 11'4"                                      |
| 2X12                  | 16"                          | 17'10"                            | 16'2"                                      |
| 2X12                  | 24"                          | 14'7"                             | 12'4"                                      |

Be sure that porch is placed so that there is a 3/8" to 1/2" gap between the framing and the home.

Once framing is in place, install an additional joist to the posts next to the home.

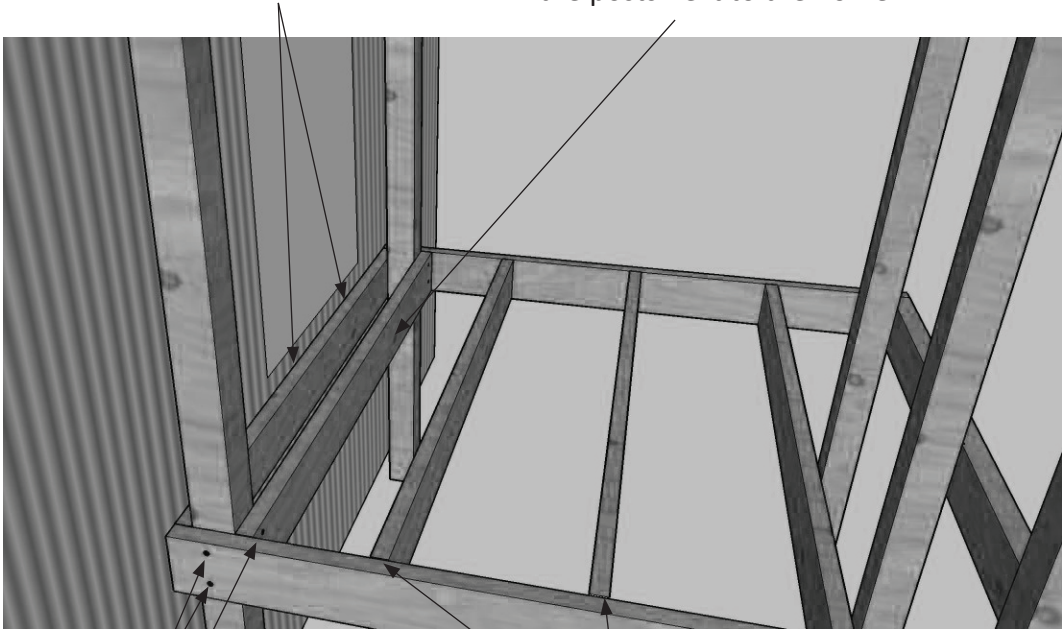

Install two 3 5/8" LedgerLoks into each framing member and post intersection

Joists are attached with joist hangers *after* the porch frame is raised and squared.

## DECKING

Decking should run perpendicular to the house, across the floor joists. 5/4" decking is the most common; it is just over an inch thick, 5.5" wide, and comes in several different lengths. When installing the decking, use 2 screws through each joist, and butt each piece of lumber up against the previous piece. Use an 8d nail as the spacing guide between boards. This will allow moisture to escape.

It is important to crown your lumber. Crowning simply means looking at the curvature of the lumber at the end, and installing the decking so that it curves down, not up. You want frowns, not smiles.

If needed, add nailers around the posts in order to create a bearing surface.

## STAIRS

The top stair tread should be a step down from the deck. ***Building code requires that the height of the rail remain consistent throughout the entire course of the stairs. This is why the first step cannot be on the same level as the porch, but instead should be a step down from the porch.*** The top of the hand rail should be 36" from the nose of each stair. While installing the hand rails be sure to measure a vertical line from each nose to the hand rail, ensuring that each measurement is a consistent 36".

- Stairs must have a minimum width of 36".
- Build stairs using three 2x12 runners. Runners are the framing members that support the treads. Stairs have a maximum rise of 7 ¾" and a minimum run of 10". However, consider who will be using these stairs. If it will be children, someone disabled, or elderly, it would be better to have a lower rise, such as 6".
- The rise is determined by measuring the overall height of the stairs and dividing that by the number of stairs to be constructed.
- Use either two 2x6s or a 2x12 for the stair treads. Make sure to crown the treads, just like you did with the decking.
- To attach the stairs to the porch framing, either construct a ledger board, or use a Simpson connector.

To construct a ledger board:

1. Notch out the stair runners so that they will sit on the runner.
2. Attach the ledger (2x6 + 2x4) to the posts with 3/8" LedgerLoks.
3. Set the stairs down on the ledger, and toe nail through the runner onto the ledger.

## CUTTING STAIR RUNNERS

1. To cut stairs, use a framing square to mark the rise and run of the steps.
2. Hold the framing square at an angle, marking the rise and run at the depth and height required.
3. Use a circular saw, or hand saw to make the initial cuts for the steps. Use a handsaw to finish the cuts; you do not want to cut past the corner, as this will create a weak spot in the runner.

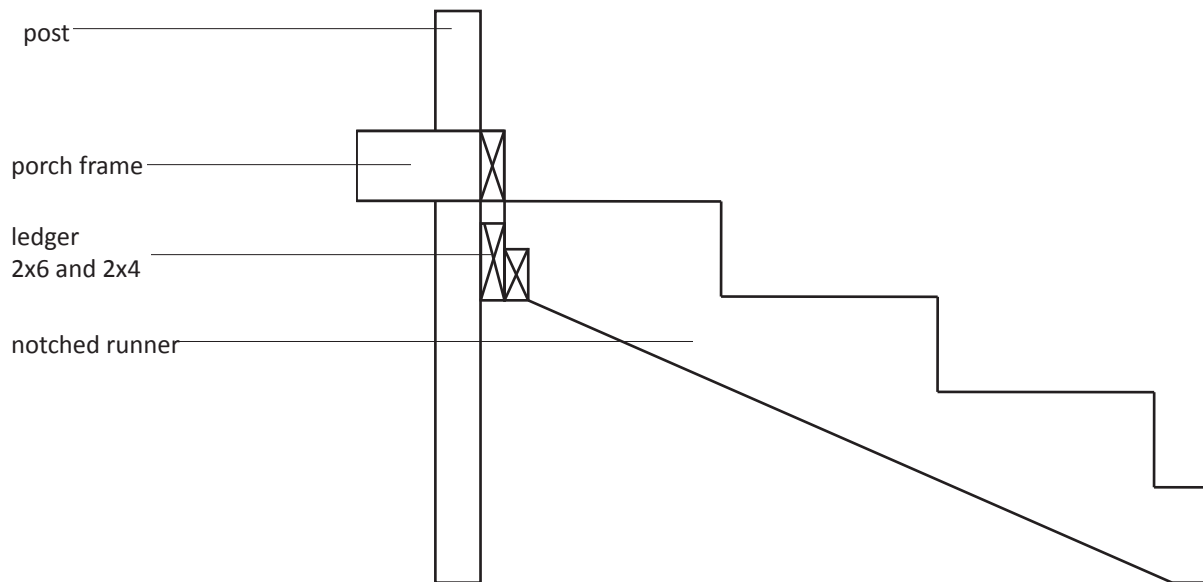
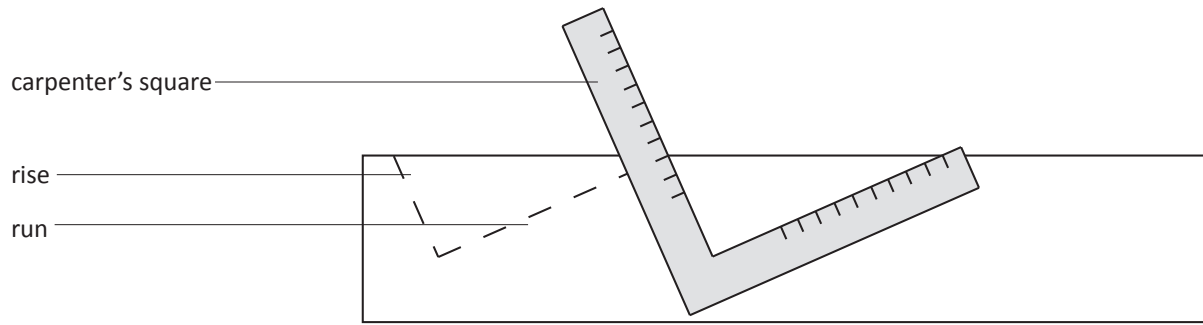

## DIAGONAL BRACING

**Diagonal bracing is required for porches over 30"**. Bracing reduces lateral movement and therefore increases the stability of the porch. The bracing will create a triangle between the framing and posts. Each post should have two diagonal braces attached to it.

The brace is constructed from treated 2x4's. Cut each end of the brace with 45° miters. The bottom of the brace should attach flush to the outside of the post 2' down from the deck. The top will attach behind the rim and band joists. The top cut will be hidden by the frame, so make sure that the seam between brace and post is tight and flush to post.

## HANDRAILS & SPINDLES

Handrails are required for porches over 30" high, or higher than 3 stairs. They should also be installed where the elderly, handicapped, or children live. The railing should rise at least 36" above the decking of the porch and stairs.

Spindles are required on all railings above 30". 2x2 pressure treated lumber can be bought at the local hardware store. For safety reasons, ASP has stopped ripping 2x4's down into 2x2's. Buy the 2x2's in increments of 36". The spindle will connect the top of the handrail to the bottom bumper (*see illustration*).

***Note: The top stair tread should be a step down from the deck. Building code requires that the height of the rail remain consistent throughout the entire course of the stairs. This is why the first step cannot be on the same level as the porch, but instead should be a step down from the porch. The top of the hand rail should be 36" from the nose of each stair. While installing the hand rails be sure to measure a vertical line from each nose to the hand rail, ensuring that each measurement is a consistent 36".***

## GUARDRAILS

Guardrails are required on all porches. Those over 30" require spindles, and under 30" require a top rail, bottom rail and center rail (*also called "barn rails"*).

The top rail should be 39" off the deck. The spindles need to have 3.5" between them. Use a 2x4 as a guide. The bottom rail should be a maximum of 3.5" off the deck. Use decking boards for the rails, and keep the spindles 1.5" from the edge. This will allow you to use 36" spindles.

Pre-drill all holes for spindles using a 1/8" drill bit.

Attach with decking screws  
(Toe screw at bottom of brace)

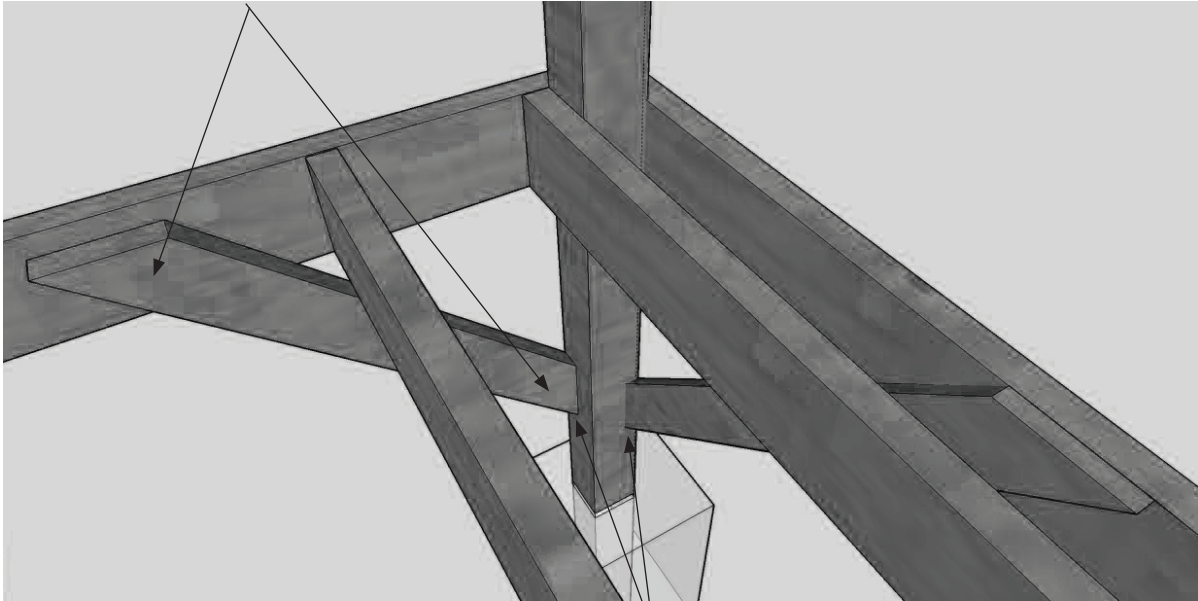

Bottom of diagonal braces  
should be 2' down from deck

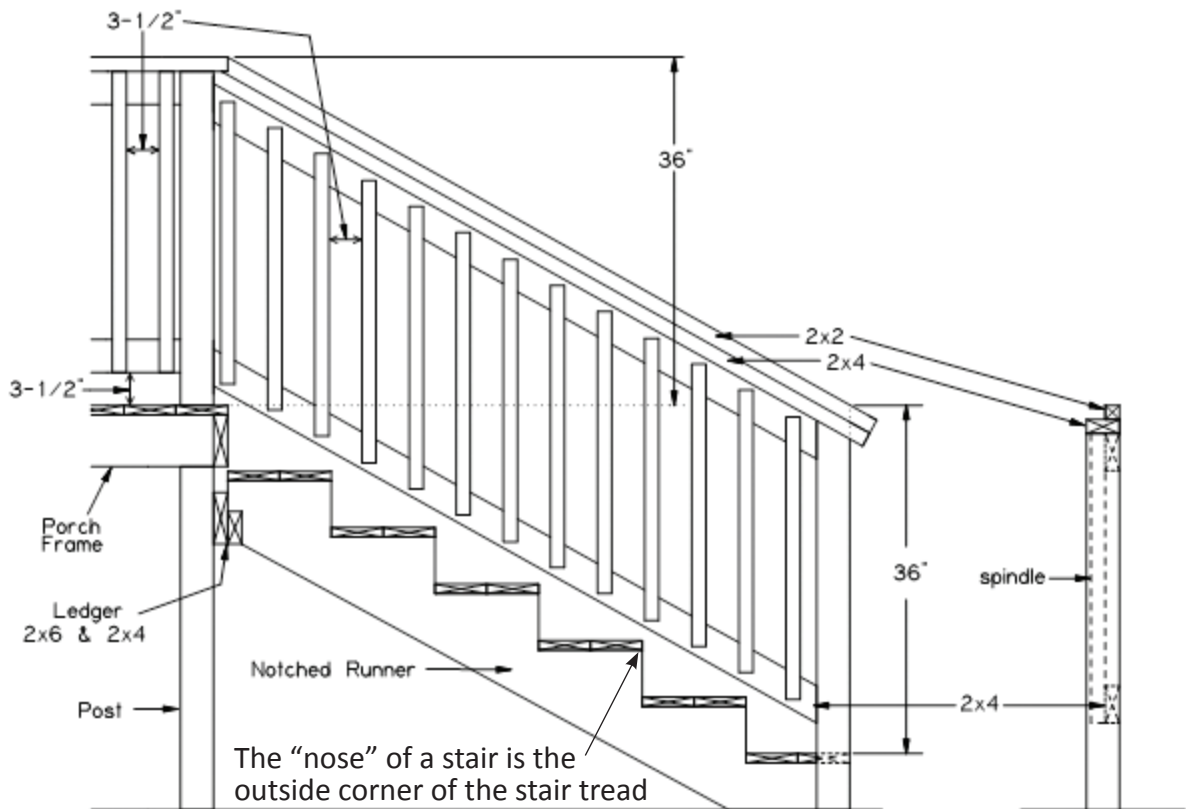

*(This page was intentionally left blank)*

# RAMPS

## SAFETY

- Drills will need to be used, ensure that when drilling a large hole, the appropriate gauge extension cord is being used (*especially when using a hammer drill*)
- Make sure a good station has been set up for cutting boards and especially posts
- ***DO NOT USE A TABLE SAW TO RIP SPINDLES. IT MAKES THIS WORK MUCH MORE DANGEROUS. DON'T DO IT!***

## RAMPS

Wheelchair ramps provide much needed access for the elderly and disabled. Careful planning is required when building a wheelchair ramp. **WHOLE HOUSE ACCESSIBILITY IS OUR GOAL.** Accessibility within the home, space, natural and manmade obstructions, and codes must be taken in to account. Plan out the entire project before beginning even the first hole.

Where you are trying to END the ramp is just as important as where you are BEGINNING the ramp. The ending location will determine the length and direction of the overall project.

### FRAMING

Ramps should have a maximum slope of 1/12; that is, for every 12" in length, the ramp can at most drop 1". ADA recommends a slope of 1/16, but 1/12 is sufficient.

All ramps must begin with a minimum landing of 5'x5'. Build this first landing as you would a porch, which is what it is.

Ramps should have a minimum clearance of 36" between handrails to allow for maneuvering. If you set your posts 39" apart from one another; this will allow you to efficiently use 8' lengths of lumber and give you 36" of clearance.

The ramp cannot run more than 30' without a landing, a flat spot in the ramp that should be 5' in length. The landing is also where a turn can occur. See the next section.

1. Plan the ramp's layout and have the ground marked for utility lines and septic lines/fields.
2. Construct a porch/landing at the beginning of the ramp, tight up against the house. See PORCHES for construction directions. This landing should be no smaller than 5'x5'.
3. Using masonry string, layout the entire ramp on the ground. Mark with bright colored marking paint, and double and triple check all measurements. Take into consideration the slope of the ground, as this may affect the length of the ramp. Posts should have 39" clearance across the ramp, and be placed 8' on center moving down the ramp.
4. Dig the holes for your posts, 16"x16"x24". Place a split cap block, castle block, or dry Sakrete in the bottom of each leveled hole. Your post will set directly on top of the block. Double check your measurements, and use post levels as you begin installing the frame.
5. Install the runners. Runners are 2x6x8s (or 2x6x16s) that act as joists. Using a level, begin at the top of the first landing and make sure that the runner will drop no more than 1" for every 12" of length. That means for a spacing of 8' posts, the runner should drop 8". Temporarily install them with screws. To attach to a landing, use either angled or open bottomed joist/rafter hangers, or construct a double ledger board to be mounted snug up underneath the runners.

Place a runner on the inside of each post. The third runner will be installed once you fasten on the ledger boards. To cut the angle required where the runner meets a landing, use a speed square. For speed square instructions, see ROOF.



## Possible Layouts

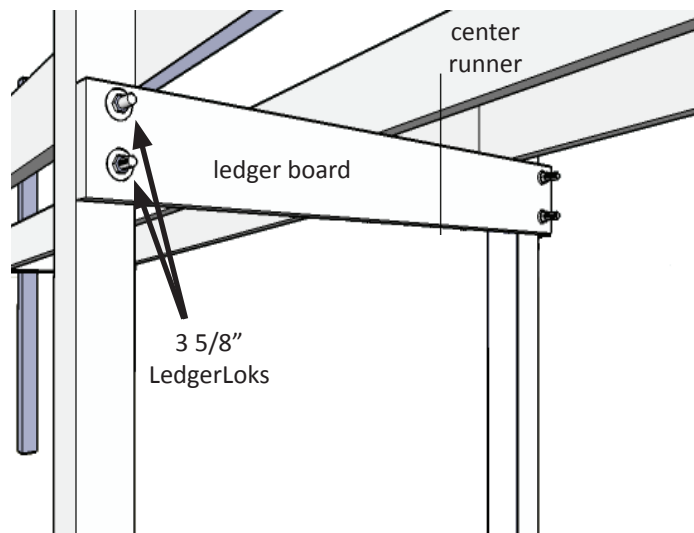
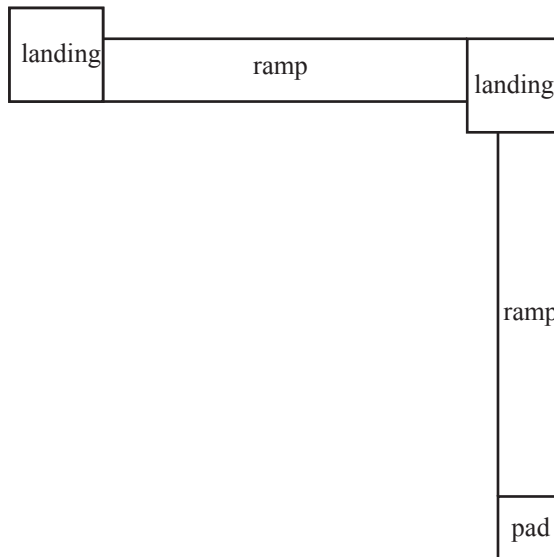
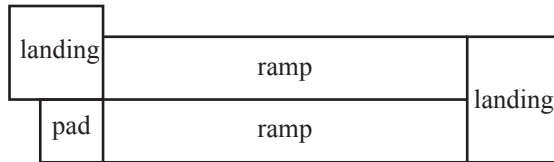
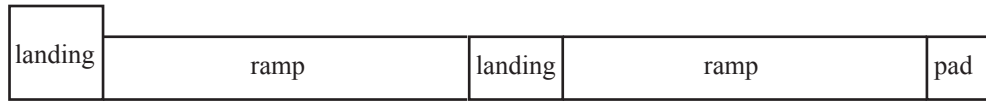

6. Install the ledger boards. A ledger board runs snugly underneath the runners, perpendicular to them and connecting pairs of posts together. Use a 2x6x8 cut in half as the ledger, which should reach to the outside of each post. A ledger board should be installed on either side of the post, giving support to all runners. Temporarily install with screws, and double check that the runners are level across the ramp.
7. Where the ramp will terminate in the ground, the runners can be sliced at a slight angle, or just buried in the ground. The last set of runners should be Ground Treated lumber, not just treated lumber. Make sure that when all said and done, the ramp will end completely flush to the ground/concrete pad, or else it is nearly impossible for someone in a wheelchair to use.
8. Go back and attach each runner into posts with 3 5/8" LedgerLoks. Do the same with the ledger boards.
9. Install the center runners, setting them on top of the ledger boards, and tacking in to place using screws.
10. Fill your post holes with gravel or dirt. Doing this last allows you to move the ramp around a bit to make sure that it will be perfect.

### *LANDINGS*

Ramps longer than 30' are required to have a landing to break the slope. No ramp should ever have a run longer than 30' without a landing; it gets difficult to push or get yourself up a really long incline.

The landing can take on several different shapes. In a straight ramp, the landing can simply be a level section of ramp that is 5' in length. If the ramp makes a 90 degree turn, the landing should be a minimum of 5'x5'. If making a 180 degree turn, the landing should be a minimum of 5'x8'.

Construct a 5'x5' or 5'x8' landing exactly as you would a porch, as that is exactly what it is. Construct a 5' level landing the same way you are constructing the ramp, as it is just a level portion of the ramp.

### *DECKING*

Use 5/4" decking boards to cover the ramp and landings. 2x6s can be used, but are more expensive and unnecessary.

When using decking boards, there is no need to leave spacing between them, as they will simply contract a bit over time, leaving that space behind. However, it is important to check and make sure that the boards are cupped downwards, thus the grains look like a rainbow, not a smile.

Fasten the decking with either 12d spiral galvanized nails, or 2.5" decking screws, 2 per runner.

For the best use of lumber, simply order decking in 4' increments (8', 12', or 16') for decking the ramp and 5'x8' landings. For 5'x5' landings, use 10' decking, cut in half.

Side view of a ramp with 180 degree turn

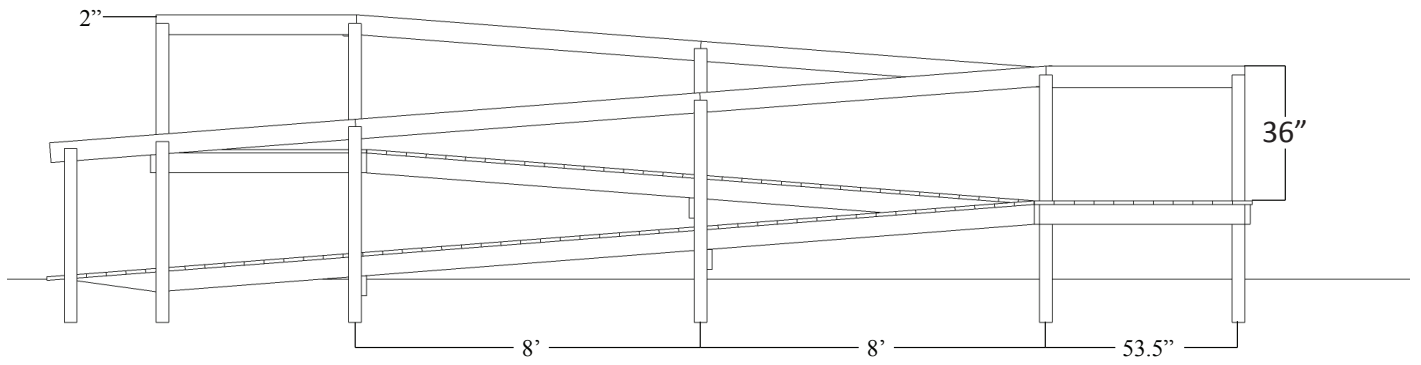

Overhead view with Measurements

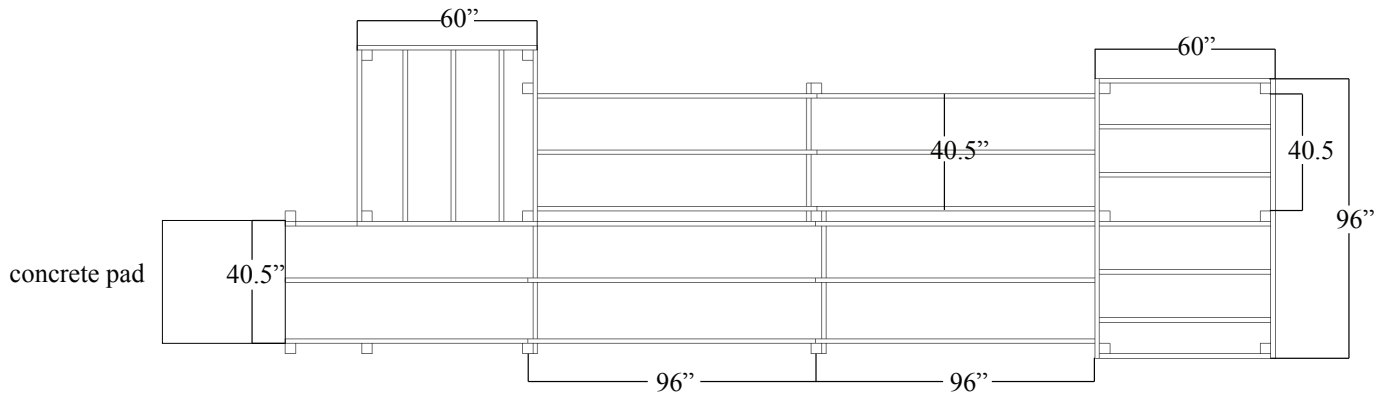

## RAILINGS

Wheelchair ramps are required to have a handrail at least 1.5" wide that is graspable from the bottom of the ramp to the top. It cannot have any obstructions. This means using a 2x6 turned on its side or on edge. The top of the handrail should be 36" above the decking.

Bumpers are also required. These should be 2x4s turned on their sides, and running 3.5" above the decking.

Spindles should be installed as well, running between the bumpers and the handrails.

1. Snap a chalk line on the posts down the ramp, at a height of 33". Cut the posts on this angle.
2. Attach the 2x6 handrails down the ramp on the inside of the 4x4s, having them stick up 3" above the tops of the posts. This will create the desired 36" height.
3. To cover the posts and tops of spindles, install a flat 2x4 on top of the 4x4s the entire length of the railing. Attach this 2x4 not only to the posts, but also to the previously installed handrail. This will strengthen the handrail and prevent any warping in the future.
4. Install the bumpers. To get the required 3.5" off the decking, simply lay a 2x4 down on its side, set the bumper on top, and attach the bumper into the posts with screws.
5. Install spindles. They should be 3.5" apart from one another, so use a 2x4 for a spacer. Also, check that they run perfectly straight up and down, or plumb, using a level. Screw into the handrail and bumper. Pre-drill all holes.

## ANOTHER METHOD FOR RAILINGS

Some states have codes that require the handrail to be no more than 3.5" wide, in addition to the previously mentioned requirements. To use this method,

1. Snap a chalk line on the posts down the ramp or stairs and cut the posts at this angle.
2. Attach a flat 2x4 on top of the posts.
3. Top rails and bumpers will be installed between the posts, requiring an angled cut. To achieve this cut, hold the 2x4 to be used as a rail in place and mark the angle at the post. The top rail should be directly under the flat 2x4 and the bumper at 3.5" above the decking. Install these rails by toe screwing into posts.
4. Attach a 2x2 on top of this flat 2x4. This will serve the purpose as the 1.5" graspable handrail that runs the length of the ramp or stairs.

## NOTE REGARDING STAIR TREADS/RAILINGS

***Note: The top stair tread should be a step down from the deck. Building code requires that the height of the rail remain consistent throughout the entire course of the stairs. This is why the first step cannot be on the same level as the porch, but instead should be a step down from the porch. The top of the hand rail should be 36" from the nose of each stair. While installing the hand rails be sure to measure a vertical line from each nose to the hand rail, ensuring that each measurement is a consistent 36".***

## PADS

Pads are not required. However, it can be extremely difficult to move around on gravel in a wheelchair, or with a cane or walker. If that is the case, a concrete pad or hard packed gravel is preferred.

### Ramp using Spindles and Barn Rails

spindles above 32"  
barn rails below 32"

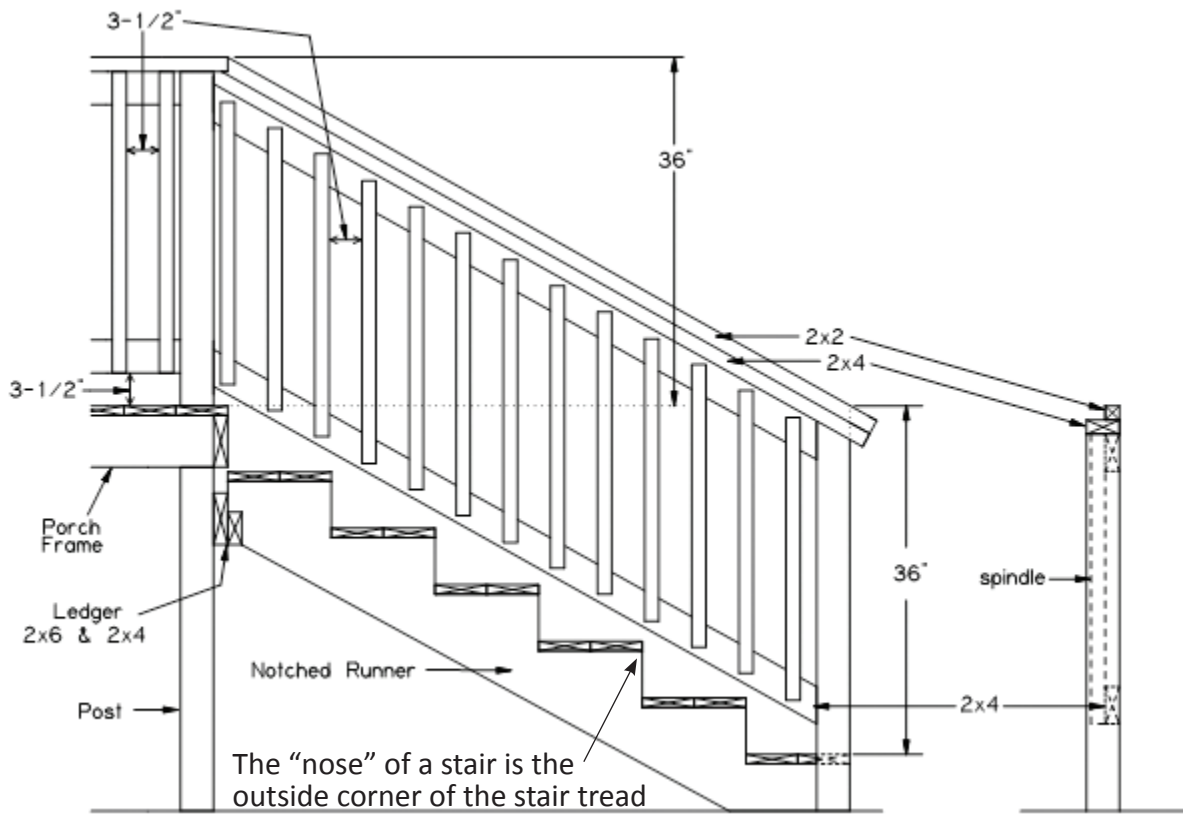
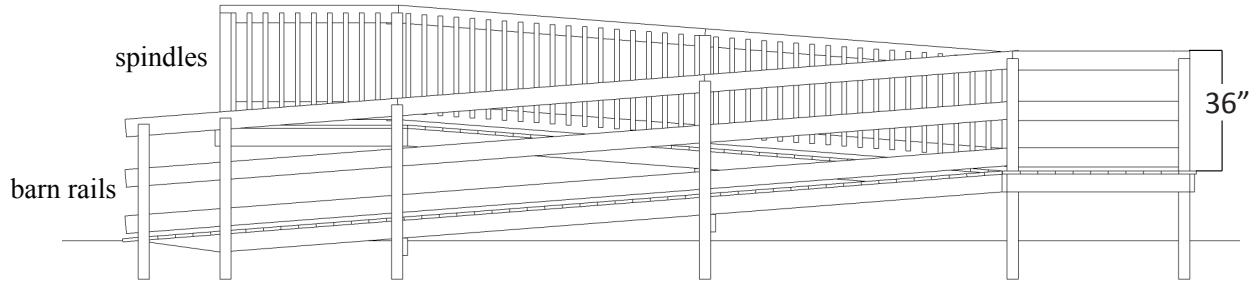

*(This page was intentionally left blank)*

# MOBILE HOMES

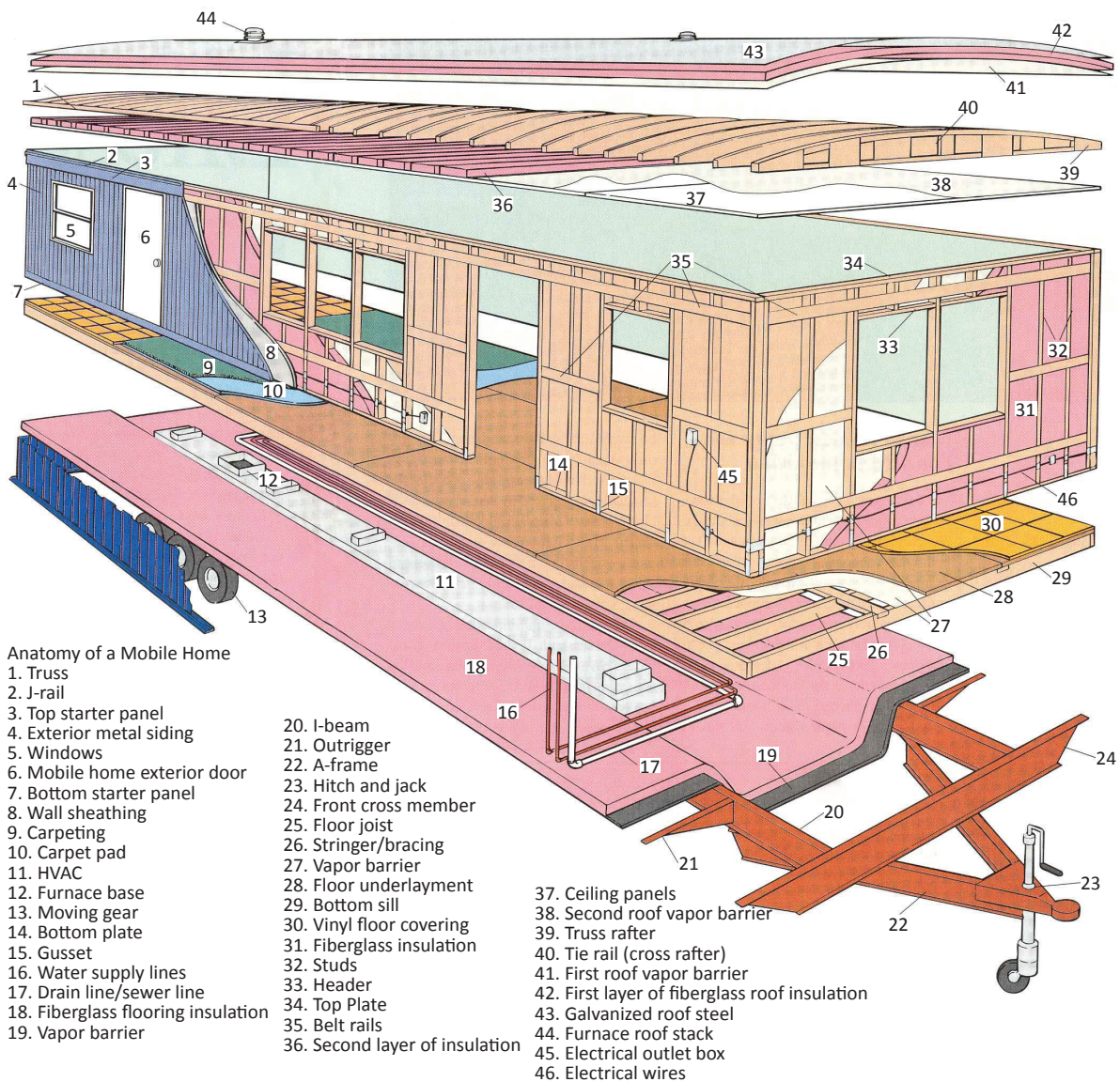



## **MOBILE HOMES**

A mobile home is a manufactured building that leaves the factory complete, equipped with plumbing, electrical and heating systems, wheels, and a hitch. It is designed to be moved on to a site, installed on a foundation of either piers or a continuous foundation, and hooked up to service facilities.

### *A BRIEF HISTORY*

Mobile homes built prior to 1978 had little regulation, and were not designed for long term permanent residency. Often they were distributed for temporary emergency housing, or used for second homes. This makes it very difficult to bring an older mobile home out of a substandard condition. The accepted belief is that it is nearly impossible to bring a pre 1980 home out of a substandard condition. Each mobile home is slightly different, and no technique will apply to every situation. Therefore, it is important to thoroughly examine each home individually. This section covers what is most commonly seen throughout Appalachia.

## **MOBILE HOME FOUNDATIONS**

Mobile homes are supported by a system of outriggers and I-beams.

- I-beams: steel structural members that run the length of the mobile home and act as the main supports for the trailer. In single wide trailers there are two I-beams.
- Outriggers: metal supports that extend out from the I-beam, catching the weight of the walls and supporting the rim joist of the floor.

Pier foundations: When installing piers under a mobile home, place them every 8' directly under the I-beams. For more info, see FOUNDATIONS.

The trailer hitch is a non-structural member of the mobile home, thus it does not need to be supported.

During transportation, some outriggers may be bent. If so, the rim joist needs to be supported directly with a 4x4. See FOUNDATIONS for directions.

Typically, direct support for the rim joist is required only directly under an exterior doorway. Support with 4x4 posts on either side of the door opening with a girder between them. See FOUNDATIONS for directions.

## **MOBILE HOME FLOORS**

Mobile home floors are typically constructed with 2x4s or 2x6s. The frame sits directly on the I-beams and outriggers, supporting the rim joists. You may find the floor joists run either perpendicular to the I-beam, or parallel with, so make sure to inspect the floor system before planning construction.

To repair the joists and band/rim joist, the walls need to be supported from the outside of the mobile home.

Mobile home sub-floors are made of a variety of materials, depending upon the year of construction. You may find OSB, particle board, something else, or a mix of sub-floor types. Always re-install 3/4" OSB, do not try and match the existing sub-floor.



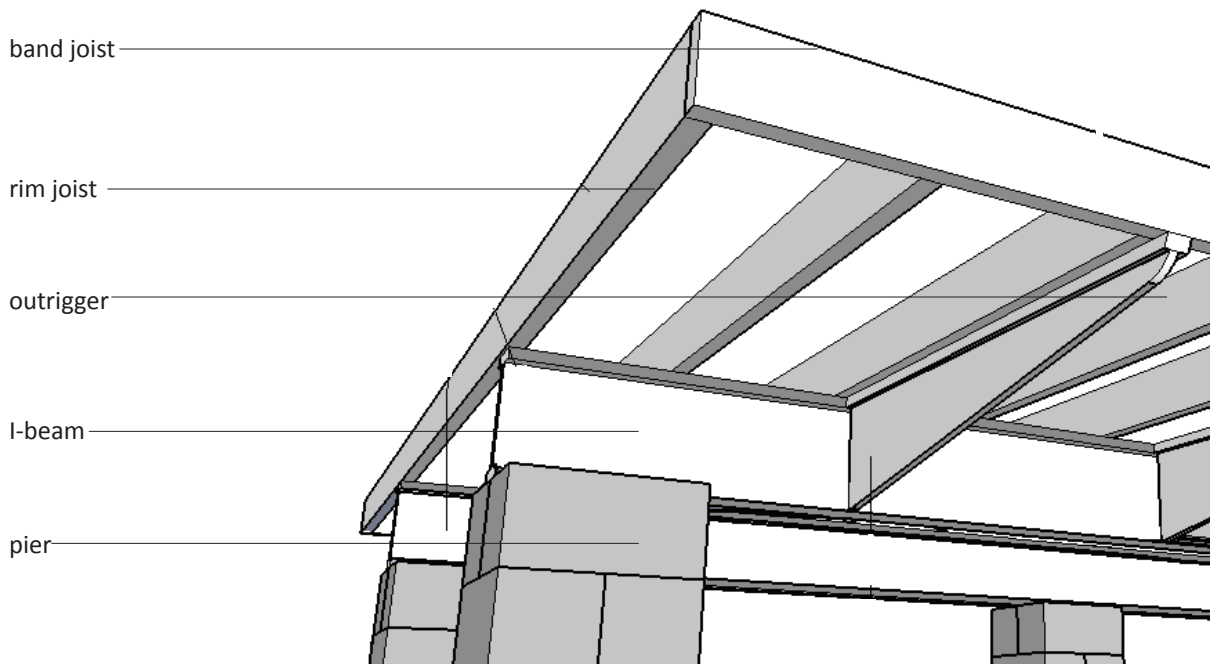
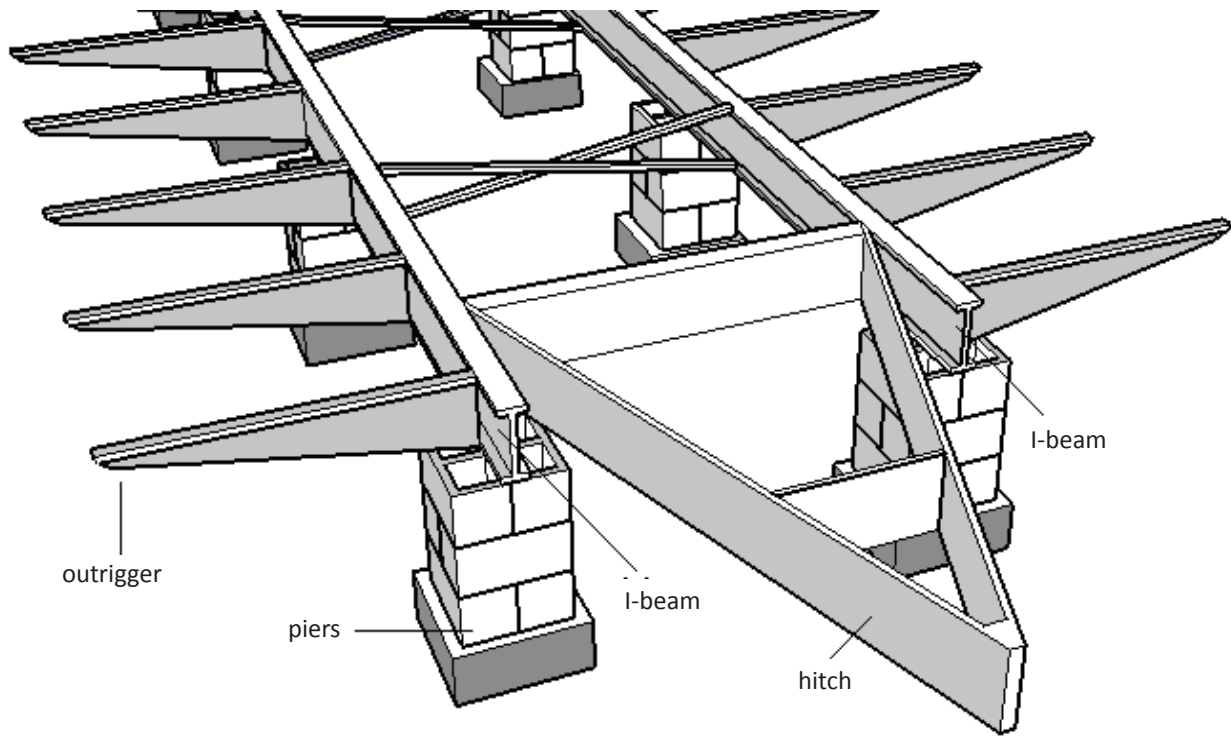

## MOBILE HOME WALLS

Mobile home walls can be constructed of 2x2s, 2x3s, or 2x4s, and may or may not be insulated. Repair as you would a typical wall, though using 2x4s is always recommended where possible, especially in load bearing walls.

Mobile homes do not have lateral bracing: the metal siding acts as the lateral bracing. Because of this, do not remove large swaths of siding at one time: try to stay below 8' sections.

If re-siding a trailer, you must install sheathing or lathing strips installed vertically 16" on center. Use vinyl siding.

## MOBILE HOME ROOFS

Many mobile home roofs are built using trusses, a structural member that combines the "rafters" with the "ceiling joists". These are tricky to repair, and are commonly cracked or completely broken.

***DO NOT WALK DIRECTLY ON THE ROOF OF A MOBILE HOME.*** This will cause further damage, and is dangerous because of the weakness of the roof's construction. Mobile home roofs are made using thin metal that is screwed into the trusses, and does not hold the weight of a person well. When needed, lay OSB down across at least 3 trusses if you must be on the roof of a mobile home.

There are several options for roof repair/replacement:

- Roof patching
- Elastomeric roof coat
- SBS Modified Bitumen Roof
- Trusses

### *ROOF PATCHING*

To patch a roof, sheet metal will be secured over the affected area to seal out water.

1. Locate the leak.
2. Once the leak is located, clean the area with plastic putty knife (not metal), scraping away any flaking or loose roof coat.
3. Place butyl tape around the area to be patched. Butyl tape is a self-sealing adhesive. It will seal around any penetrations. Silicon caulk can also be used.
4. Cut a piece of sheet metal that will extend at least 2-3" on all sides of the area.
5. Fasten the sheet metal with sheet metal screws through the butyl tape. Start with screws every 2"; if this does not create a tight enough seal, screw every 1".
6. Seal around the seams and screw heads with silicone caulk. When the caulk dries, cover the entire area with roof coating.

### *ELASTOMERIC ROOF COATING*

1. Clean the roof off. Scrape the roof using plastic putty knives (do not use metal), knocking off loose and flaky pieces. Use a wire brush, brushing the entire roof. Always stay on a sheet of OSB while working on the roof, or work off of a ladder.
2. The roof must have tight overlapping joints for the product to effectively fill all holes and cracks. This means that you should also Roof Patch before using the Elastomeric Roof Coat, especially on larger problem areas.
3. Mix the roof coat extremely well. If possible, turn the bucket upside down 1 day prior to beginning work.
4. Follow the directions on the bucket to install the roof coat. There should be at least 1-2 days of drying time without rain afterwards. Check the forecast.

### *OTHER OPTIONS*

For SBS Modified Bitumen Roof and Trusses, see ROOF COVERING.

*(This page was intentionally left blank)*

# GLOSSARY

## #

**5 V TIN:** A metal roofing material with five ridges, two on each end and one in the middle. It comes in 25 ½" sections with a finished face of 24".

## A

## B

**BAFFLES:** Cardboard or foam barriers placed between rafters to prevent insulation from hindering air flow in the soffits.

**BAND JOIST:** A component of the box joist that runs perpendicular to the common joists, enabling them to maintain spacing and stiffening their ends. There is typically a double band joist on pier foundations and a single band joist on continuous foundation. In many areas, the band joist refers to the exterior joist between floors at which the common joists terminate.

**BIRD'S MOUTH:** A notch that allows the rafter to sit on the top plate.

**BATTEN STRIP:** A piece of rough cut lumber placed over boards to cover gaps on board and batten siding.

**BOTTOM CHORD:** Acts as the ceiling joist, typically spanning the entire width of the roof.

**BOTTOM PLATE:** Framing member that rests on the sub-floor. All of the studs rest on the bottom plate.

**BOX JOIST:** Constructed by joining two double rim joists on the inside ends of two double band joists, forming a box. It acts as the outside perimeter of a floor.

**BRIDGING:** A type of bracing installed between common joists to increase a floor's stiffness while holding joists in place and preventing them from twisting.

**BUTYL TAPE:** A form of tape that is self-sealing.

## C

**CALIFORNIA CORNER:** A method of wall framing used to create a corner.

**CANTILEVER:** Any structural part of a building that projects beyond its support and overhang.

**CAP BLOCKS:** Solid concrete blocks that have a nominal measurement of 1  $\frac{5}{8}$ " or 3  $\frac{5}{8}$ ".

**CARPORT ROOF:** A freestanding roof constructed over trailers.

**CEILING JOIST:** A series of parallel framing members meant to add support to the walls.

**CELLULOSE INSULATION:** Loose insulation, with an R-value of 3.7 per inch, which is blown into place using a mechanical blower. Often composed of recycled paper and other materials.

**CMU:** Concrete masonry unit. Sometimes referred to as concrete block or cinder block.

**COLLAR TIES:** Boards that run across opposite rafter pairs at  $\frac{1}{3}$  the height of the roof to help prevent the roof from spreading.

**COMMON JOIST:** Framing member that run perpendicular to the band joists, typically at 16" or 24". The common joists connect to both band joists. Joists are sized according a prescribed span chart.

**CONCRETE:** A composite building material made from the combination of aggregate, sand, and a cement binder.

**CONTINUOUS FOUNDATION:** A foundation in which all sides are in direct contact with, and mechanically fastened to each other.

**CORNER BEAD:** A strip of formed sheet metal or vinyl placed on outside comers of drywall before applying drywall compound.

**CRIB STACK:** A method of stacking concrete blocks where each row is stacked perpendicular to the previous row.

**CRIPPLES:** Short studs placed between the header and a top plate or between a sill and bottom plate.

**CROWN VETCH:** The most commonly used plant for ground cover and erosion prevention. It grows slower than ivy or periwinkles, but is a hardier plant that requires little to no maintenance.

## D

**DEADMAN:** A buried railroad tie that is used as an anchor for a retaining wall.

**DIMPLER BIT:** a special driver inserted into a drill that allows you to consistently countersink screws.

**DOWNSPOUT:** A pipe for draining water from roof gutters. Also referred to as a leader

**DRAINAGE DITCH:** A ditch used to divert water away from a home or certain area. They typically are 18"x18" with 2" of gravel, followed by perforated pipe, with another 12" of gravel placed on top of the pipe.

**DRIP EDGE:** The metal or vinyl protection along the eaves and rakes of a roof that allows water to run off or drip away from the roof decking.

**DRIP LINE:** Where water falls from the eave of a house onto a stone channel below that is then diverted away from the house. A drip line can be used in place of guttering.

**DRY LINE:** a string tied between two points. Serves as a guide for your project.

**DRYWALL:** A basic interior building material consisting of big sheets of pressed gypsum faced with heavy paper on both sides. Also known as gypsum board, plasterboard, and Sheetrock™.

**DRYWALL TAPE:** Made from paper or fiberglass, it is applied to drywall seams or cracks as a base for joint compound.

## **E**

**EAVE:** The lower horizontal edge of a roof.

**EGRESS WINDOWS:** Windows that allow access in and out of an area. Size is regulated by local building codes.

**ELASTOMERIC ROOF COAT:** A liquid coating applied to trailer roofs.

**EPDM:** A synthetic rubber coating available in sheet or liquid form that is non-permeable, and will hold pooling water.

**EXFILTRATION:** The uncontrolled movement of air out of a building.

**EXHAUST VENT:** A vent that allows air to escape from the attic space.

## **F**

**FASCIA:** A horizontal band or board used to conceal the ends of rafters.

**FELT PAPER:** A tar-saturated underlayment placed under roofing as an added measure of protection.

**FLAT ROOF:** A roof that is less than an 1/12 pitch.

**FLY RAFTER:** A rafter that extends beyond the edge of the home. Also called a Barge rafter.

**FOOTING:** The concrete base that supports any type of pier or wall.

**FOUNDATION:** That part of a structure that is in direct contact with, and transmits the load of the structure, to the ground .

**FURRING STRIPS:** Boards that are installed perpendicular to the framing to provide nailing surfaces for coverings.

## **G**

**GABLE VENTS:** Vents placed on the gable sides of the roof, in pairs, allowing air to enter the attic space.

**GALVANIZED:** A zinc coating applied to metal to increase corrosion resistance.

**GIRDER:** A horizontal beam used as a main support for a structure. Typically made of 2-- 2x8s fastened and glued together.

**GLAZING:** A pliable substance applied between the window sash and the lights of glass to seal against the elements and to adhere the glass to the sash.

**GREENBOARD:** A water resistant type of drywall. Can be green or blue in color.

**GUSSET PLATE:** A piece of plywood or metal used to connect various parts of the truss.

**GUTTER:** A channel along the eaves or on the roof; collects and carries away rainwater.

**GUTTER APRON OR FLASHING:** Metal flashing that is usually 2"x2" and is under the eave end of the roof covering and over the gutter. The apron forces the water to go into the gutter.

## **H**

**H-CLIP:** Metal clip that holds adjacent edges of roof decking in alignment.

**HEADER:** A heavy beam that extends across the top of the rough opening to prevent the weight of wall or roof from resting on the window or door frame.

**HOLE SAW:** An attachment for a drill which consists of a circular saw blade, used to cut holes.

**HOUSE WRAP:** A barrier wrapped around a house to save energy and act as a moisture barrier.

**HURRICANE STRAP:** A strap designed to tie ceiling joists to the top plate of an exterior wall.

## **I**

**I-BEAMS:** Steel beams that run the entire length of a trailer and act as the main supports. In trailers, there are two I-beams that run parallel to each other.

**ICE AND WATER SHIELD:** Also called weatherguard or weathershield. A self-adhering, rubberized, rolled roofing product that is applied before the final roof product is installed. It produces a weather tight barrier.

**INFILTRATION:** The uncontrolled movement of air into a building.

**INTAKE VENTS:** Vents that allow air to flow into the attic area.

**IVY:** A very invasive plant, and can be difficult to tame. This plant is used to prevent erosion on hillsides.

## **J**

**J CHANNEL:** A channel used to cover the ends of vinyl siding.

**JACK STUD:** Framing members, generally 2x4s, which form the inside of the window or door opening, running from the bottom plate to the header.

**JOINT COMPOUND:** A paste used in combination with paper tape to conceal joints between drywall panels. Also known as drywall "mud".

**JOIST HANGER:** A fabricated metal slot installed on a band joist to act as the support for a common joist.



## K

**K-BRACING:** A form of let in bracing that is used when the brace cannot span at least four studs.

**KICKERS:** Temporary supports installed outside a home that run diagonally from the top of the wall to the ground. Used to temporarily support roof loads while floors and walls are repaired. The formula for kickers is for every 4' of vertical wall height the base of the kicker is out 1 foot.

**KING STUD:** A vertical 2x4 framing member that runs continuously from the bottom plate to the top plate.

## L

**LADDER FRAMING:** A method of framing used to attach interior walls to exterior walls.

**LAP SIDING:** Wood or fiberboard strips 6" to 12" wide, overlapping each other to cover the home.

**LEDGER:** A horizontal board attached to a band joist and is used as a shelf-like support for common joists.

**LEDGER LOKS:** A wood screw engineered to fasten a deck ledger board to the rim joist of a house with no predrilling. They are coated to protect against corrosion, even in pressure treated wood. The built-in washer head eliminates the need for an additional washer, saving time and money. The large hex-head allows for greater bit engagement, reducing cam-out. *LedgerLOK is a code approved deck ledger board fastener that replaces lag screws and through-bolts.*

**LET-IN BRACING:** 1x6 wall bracing that is cut into the studs of an exterior corner to provide lateral support for the wall.

**LEVEL:** A line that is true horizontally.

**LIGHTNING RODS:** Metal rods that can be bent to secure insulation between the joists.

**LOADS:** Weight (snow, wood, household furnishings, etc) and forces (gravity, wind, etc.) that exerts pressure on a house.

**LOOKOUT:** Supports for a fly rafter that are notched into the final two rafters, spaced on 32" centers.

## M

**MASONITE:** A type of composite lap siding.

**MORTAR:** A composite building material composed of sand and a cement binder used to bind blocks or bricks.

**MORTISE:** A hole, slot, groove, or other recess into which another element fits.

**MUNTIN:** The small members that divide the glass in a window frame.

**MUSHROOM VENT:** A static vent attached to the decking of the roof that has a cap that prevents water from entering the roof, while vents beneath the cap to allow air to escape.

## **N**

**NAILER:** A piece of material attached to framing to provide a nailing surface.

**NEOPRENE SCREWS:** A sheet metal screw with neoprene around the head, designed to create a water tight seal.

**NOMINAL SIZE:** The actual size of the window or door.

## **O**

**ON CENTER:** The term used to define the measured spacing between frames, studs, joists, rafters, etc. On center measurements are taken from the center of one member to the center of the adjoining member.

**OUTRIGGERS:** Metal supports that extend from the I-beams on either side of a trailer to support the band joist of the floor.

## **P**

**PERENNIAL VINCA (PERIWINKLE):** An invasive plant that is harder to grow than ivy or crown vetch. This plant is used to prevent erosion on hillsides.

**PIPE BOOT:** A prefabricated flashing piece used to flash around circular pipe penetrations on roofs.

**PITCH:** A roof's rise (vertical distance) over run (horizontal distance).

**PLUMB:** A true vertical line. A line that is perpendicular to a level horizontal line.

**PUSH POINT:** A metal brace that is used to hold a panel of glass in place, when the panel is larger than 24"

## **Q**

## **R**

**R-VALUE (RESISTANCE VALUE):** The rating given to a material for its ability to resist heat transfer.

**RAFTER:** A framing member that extends from a ridge (or hip) to the top plate of a wall to support the decking and roof covering.

**RAKE:** The sloped edge of a roof.

**REBAR:** Steel reinforcing rods.

**RETAINING WALL:** A wall that has been built on a slope to keep the soil from sliding or eroding.

**RIDGE BOARD:** A horizontal framing member at the top of the roof where the rafters meet. The ridge board always runs perpendicular to the ceiling joists.

**RIDGE CAP:** Material applied over the ridge or hip of a roof.

**RIDGE VENT:** A vent attached to the peak of a roofline to allow air to escape.

**RIM JOIST:** A component of the box joist that runs parallel with the floor joist and ends the floor system. The rim joist always ends on the band joist. There is typically a double rim joist on pier foundations, and a single rim joist on continuous foundations.

**ROLLED ROOFING:** Asphalt roofing material similar to shingles but on a roll 36" wide.

**ROUGH OPENING:** The size of a hole to be framed in the wall for a window or door.

**RUNNER:** A support for stairs or wheelchair ramps. Also called a stringer.

## **S**

**SBS MODIFIED BITUMEN ROOF SYSTEM:** A rubberized flexible roofing cap sheet used for low-slope applications. It is self-adhering.

**SCAB:** Lumber fastened by nails to another piece of framing for reinforcement. Scabs should extend 2' beyond the weakened area of the framing.

**SHIMS:** Wedges used for bracing or leveling framing members.

**SILL:** 1) A wooden member that rests on top of the foundation 2) Horizontal member that forms the bottom of a window frame.

**SILL SEALER:** a flexible piece of foam that seals the crack between the foundation and sill plate.

**SOFFIT:** A material, which covers the underside of a roof overhang.

**SOFFIT VENTS:** Vents placed or built into the soffit allowing air to enter through the underside of the eave.

**SONO TUBE:** A cardboard tube that is filled with concrete and acts as a foundational pier.

**SPLASH BLOCK:** A slanted block used to divert runoff water from a downspout away from the foundation.

**STACK EFFECT:** the escape of air through openings in the upper part of a building while being replaced by outside air entering through a lower opening.

**STIFFBACK:** A framing member that helps limit floor deflection. Composed of a 2x4 and 2x6 in an "L" shape attached to the underside of floor joists.

**STUDS:** The vertical member of the wall, used as supports. Normally cut to a length of 92 5/8".

**SUBFLOOR:** Boards or plywood installed over joists on which the finish floor is laid.

**SYNTHETIC UNDERLAYMENT:** A polypropylene coated, weather resistant, woven fabric, used in place of felt paper on a roof.

## **T**

**T1-11:** A type of exterior siding made from plywood.

**TERMINATION BAR:** Galvanized or aluminum flashing used to attach the SBS to the eaves and gable ends of mobile homes. It is 1" wide, and is attached with neoprene backed screws.

**TOENAIL:** The process of driving a nail at an angle.

**TOP CHORD:** Acts as the truss system's rafter.

**TOP PLATE:** Rests on top of the studs and is used to support the roof load, or the second story of the home. The top plate is doubled to increase strength and tie walls together.

**TORPEDO LEVEL:** A level that is from 10" to 12" long.

**TPI:** Teeth per inch.

**TRUSS:** A manufactured wood member often in the form of a large triangle which is used to form the ceiling joists and rafters.

## **U**

**UNDERPINNING:** A skirt that is installed around the base of a home with a pier foundation to help insulate and protect the home from the weather.

## **V**

**VALLEY:** The "V" created where two sloping roofs meet.

**VENTILATION:** The controlled movement of air into and out of a building.

## **W**

**WHIRLYBIRDS:** A turbine attached to the decking of the roof that is powered by wind and pulls air out of the attic area.

## **X**

## **Y**

## **Z**

**Z FLASHING:** Flashing shaped in a Z used to protect horizontal overlaps between exterior panels and over doors and windows.